

www.klingseisen.de

Tools & solutions

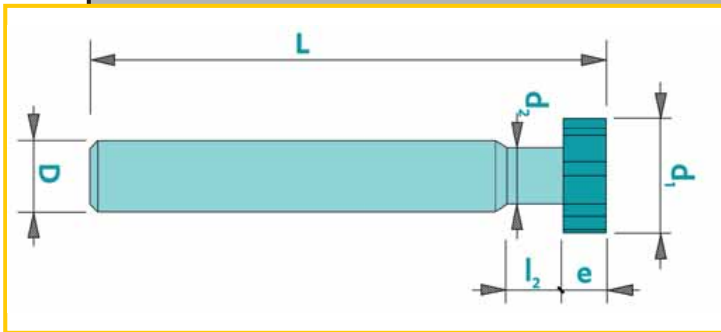

Katalog

Werkzeuge für Chirurgie

2019/2020

 LOUIS BELET®
Swiss Cutting tools
EKALINE©

T-Nutenfräser
VHM Metallkreissägen
VHM Bohrungsfräser

Brunnenstraße 2 · 78554 Aldingen · Tel. (07424) 98192-0
Fax. (07424) 84601 · info@klingseisen.de



: Inhaltsverzeichnis

Schaftfräser für Chirurgie	2
T-Nutenfräser HSS-E - Kat. 50000	2
T-Nutenfräser VHM - Kat. 117	3
T-Nutenformfräser HSS-E - Kat. 50100	5
T-Nutenformfräser VHM - Kat. 117R	6
T-Nutenfräser VHM mit Konvexradius - Kat. 117-2	7
Prismenfräser VHM 90 Grad - Kat. 117-3	8
Prismenfräser VHM 60 Grad - Kat. 117-4	9
Formfräser VHM mit konkavem Radius Kat. 118-0	10
Schwalbenschwanzfräser VHM 45 Grad - Kat. 118-1	11
Schwalbenschwanzfräser VHM 60 Grad - Kat. 118-2	12
Viertelkreisfräser VHM mit konkavem Radius - Kat. 118	13
VHM Kreissägen	14
VHM Kreissägen Typ 101 feine Verzahnung	14
VHM Kreissägen Typ 102 grobe Verzahnung	17
Aufnahmen für Kreissägen	20
VHM Bohrungsfräser für Chirurgie	21
VHM Winkelstirnfräser 60Grad 2 Schnitte Kat. 228	21
VHM Winkelstirnfräser 45Grad 2 Schnitte Kat. 228-1	22
VHM Winkelstirnfräser 30Grad 1 Schnitt Kat. 228-3	23
VHM Winkelstirnfräser 45Grad 1 Schnitt Kat. 228-4	24
VHM Winkelstirnfräser 60Grad 1 Schnitt Kat. 228-5	25
VHM Prismenfräser 60Grad Kat. 229-1	26
VHM Prismenfräser 90Grad Kat. 229-2	27
VHM Prismenfräser 120Grad Kat. 229-3	28
VHM Radiusfräser konvex Kat. 232	29
VHM Radiusfräser konkav Kat. 234	32



Schaftfräser für Chirurgie: T-Nutenfräser HSS-E - Kat. 50000

Beschreibung:

Schlitzfräser aus HSS-E (EMo5Co5)

Bogenzahn

Auf Wunsch mit Beschichtung lieferbar.

EKALINE®

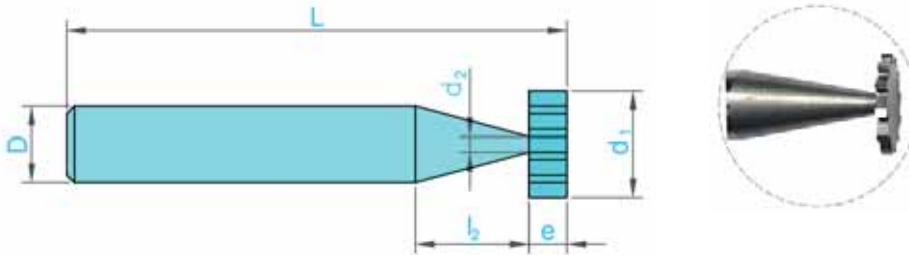

Typ	d1	e	d2	D	l2	L	Z	Artikelcode	EUR
50000	6,5	1,5	2,1	6	25	65	10	QEKALINE500006,5X1,5	40.71
50000	8,5	0,8	2,2	6	25	65	10	QEKALINE500008,5X0,8	43.57
50000	8,5	1	2,2	6	25	65	10	QEKALINE500008,5X1,0	43.57
50000	8,5	1,5	2,2	6	25	65	10	QEKALINE500008,5X1,5	43.57
50000	10,5	1	2,5	10	25	65	12	QEKALINE5000010,5X1,0	46.43
50000	12	0,8	2,7	10	25	65	12	QEKALINE5000012,0X0,8	47.86
50000	12	1	2,7	10	25	65	12	QEKALINE5000012,0X1,0	47.86
50000	12	1,2	2,7	10	25	65	12	QEKALINE5000012,0X1,2	47.86
50000	12	1,5	2,7	10	25	65	12	QEKALINE5000012,0X1,5	47.86
50000	12	2	2,7	10	25	65	12	QEKALINE5000012,0X2,0	47.86
50000	16,5	1,8	3,4	12	25	65	12	QEKALINE5000016,5X1,8	62.14
50000	20	0,8	5	12	25	65	12	QEKALINE5000020,0X0,8	74.29
50000	20	1,8	5	12	25	65	12	QEKALINE5000020,0X1,8	74.29
50000	20	2	5	12	25	65	12	QEKALINE5000020,0X2,0	74.29
50000	25,5	2,5	5	12	25	65	14	QEKALINE5000025,5X2,5	83.57
50000	30,5	2,5	5	12	25	65	14	QEKALINE5000030,5X2,5	92.86

Weitere Abmessungen auf Anfrage lieferbar.



Schaftfräser für Chirurgie: T-Nutenfräser VHM - Kat. 117

Beschreibung:

T-Nutenfräser aus VHM
gerade Zahnung
2 Schnitte



Auf Wunsch mit Beschichtung lieferbar.

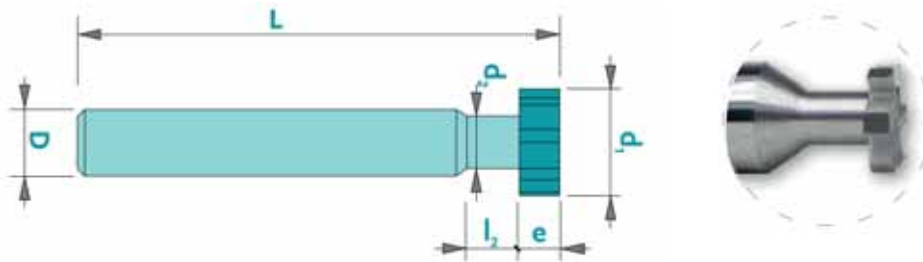

Typ	d1	e	d2	l2	D	L	Z	Artikelcode	EUR
117	1	0,2	0,5	1	3	38	5	QBELET1171,00X0,20Z5	53.10
117	1	0,3	0,5	1	3	38	5	QBELET1171,00X0,30Z5	53.10
117	1	0,4	0,5	1	3	38	5	QBELET1171,00X0,40Z5	53.10
117	1	0,5	0,5	1	3	38	5	QBELET1171,00X0,50Z5	53.10
117	1	0,6	0,5	1	3	38	5	QBELET1171,00X0,60Z5	53.10
117	1,5	0,8	0,5	1	3	38	5	QBELET1171,50X0,80Z5	60.00
117	1,7	0,8	0,5	1	3	38	5	QBELET1171,70X0,80Z5	60.00
117	2	0,2	1	2	4	38	5	QBELET1172,00X0,20Z5	44.60
117	2	0,3	1	2	4	38	5	QBELET1172,00X0,30Z5	44.60
117	2	0,4	1	2	4	38	5	QBELET1172,00X0,40Z5	44.60
117	2	0,5	1	2	4	38	5	QBELET1172,00X0,50Z5	44.60
117	2	0,6	1	2	4	38	5	QBELET1172,00X0,60Z5	44.60
117	2	0,8	1	2	4	38	5	QBELET1172,00X0,80Z5	44.60
117	2	1	1	2	4	38	5	QBELET1172,00X1,00Z5	44.60
117	2,2	1	1	2	4	38	5	QBELET1172,20X1,00Z5	60.00
117	2,4	1	1	2	4	38	5	QBELET1172,40X1,00Z5	60.00
117	3	0,2	1,5	2	4	38	5	QBELET1173,00X0,20Z5	44.60
117	3	0,3	1,5	2	4	38	5	QBELET1173,00X0,30Z5	44.60
117	3	0,4	1,5	2	4	38	5	QBELET1173,00X0,40Z5	44.60
117	3	0,5	1,5	2	4	38	5	QBELET1173,00X0,50Z5	44.60
117	3	0,6	1,5	2	4	38	5	QBELET1173,00X0,60Z5	44.60
117	3	0,8	1,5	2	4	38	5	QBELET1173,00X0,80Z5	44.60
117	3	1	1,5	2	4	38	5	QBELET1173,00X1,00Z5	44.60
117	3	1,2	1,5	2	4	38	5	QBELET1173,00X1,20Z5	44.60
117	3	1,5	1,5	2	4	38	5	QBELET1173,00X1,50Z5	44.60
117	3,1	1	1,5	2	4	38	5	QBELET1173,10X1,00Z5	63.33



Typ	d1	e	d2	l2	D	L	Z	Artikelcode	EUR
117	3,1	1,2	1,5	2	4	38	5	QBELET1173,10X1,20Z5	63.33
117	3,5	1	1,5	2	4	38	5	QBELET1173,50X1,00Z5	63.33
117	3,5	1,2	1,5	2	4	38	5	QBELET1173,50X1,20Z5	63.33
117	3,5	1,3	1,5	2	4	38	5	QBELET1173,50X1,30Z5	63.33
117	3,5	1,5	1,5	2	4	38	5	QBELET1173,50X1,50Z5	63.33
117	4	0,2	2,5	3	4	38	5	QBELET1174,00X0,20Z5	51.00
117	4	0,3	2,5	3	4	38	5	QBELET1174,00X0,30Z5	51.00
117	4	0,4	2,5	3	4	38	5	QBELET1174,00X0,40Z5	51.00
117	4	0,5	2,5	3	4	38	5	QBELET1174,00X0,50Z5	51.00
117	4	0,6	2,5	3	4	38	5	QBELET1174,00X0,60Z5	51.00
117	4	0,8	2,5	3	4	38	5	QBELET1174,00X0,80Z5	51.00
117	4	1	2,5	3	4	38	5	QBELET1174,00X1,00Z5	51.00
117	4	1,2	2,5	3	4	38	5	QBELET1174,00X1,20Z5	51.00
117	4	1,5	2,5	3	4	38	5	QBELET1174,00X1,50Z5	51.00
117	4,2	1,5	2,5	3	4	38	5	QBELET1174,20X1,50Z5	65.00
117	4,5	1	2,5	3	4	38	5	QBELET1174,50X1,00Z5	
117	5	0,5	3	3	5	38	5	QBELET1175,00X0,50Z5	58.40
117	5	0,6	3	3	5	38	5	QBELET1175,00X0,60Z5	58.40
117	5	0,8	3	3	5	38	5	QBELET1175,00X0,80Z5	58.40
117	5	1	3	3	5	38	5	QBELET1175,00X1,00Z5	58.40
117	5	1,2	3	3	5	38	5	QBELET1175,00X1,20Z5	58.40
117	5	1,5	3	3	5	38	5	QBELET1175,00X1,50Z5	58.40
117	6	0,5	3,5	4	6	38	6	QBELET1176,00X0,50Z6	58.40
117	6	0,6	3,5	4	6	38	6	QBELET1176,00X0,60Z6	58.40
117	6	0,8	3,5	4	6	38	6	QBELET1176,00X0,80Z6	58.40
117	6	1	3,5	4	6	38	6	QBELET1176,00X1,00Z6	58.40
117	6	1,2	3,5	4	6	38	6	QBELET1176,00X1,20Z6	58.40
117	6	1,5	3,5	4	6	38	6	QBELET1176,00X1,50Z6	58.40
117	6	2	3,5	4	6	38	6	QBELET1176,00X2,00Z6	58.40
117	8	0,5	4	5	8	51	8	QBELET1178,00X0,50Z8	72.20
117	8	0,8	4	5	8	51	8	QBELET1178,00X0,80Z8	72.20
117	8	1	4	5	8	51	8	QBELET1178,00X1,00Z8	72.20
117	8	1,2	4	5	8	51	8	QBELET1178,00X1,20Z8	72.20
117	8	1,5	4	5	8	51	8	QBELET1178,00X1,50Z8	72.20
117	8	2	4	5	8	51	8	QBELET1178,00X2,00Z8	72.20
117	8	2,5	4	5	8	51	8	QBELET1178,00X2,50Z8	72.20
117	10	0,5	5	5	10	51	10	QBELET11710,00X0,50Z10	76.40
117	10	0,8	5	5	10	51	10	QBELET11710,00X0,80Z10	76.40
117	10	1	5	5	10	51	10	QBELET11710,00X1,00Z10	76.40
117	10	1,2	5	5	10	51	10	QBELET11710,00X1,20Z10	76.40
117	10	1,5	5	5	10	51	10	QBELET11710,00X1,50Z10	76.40
117	10	2	5	5	10	51	10	QBELET11710,00X2,00Z10	76.40



Typ	d1	e	d2	l2	D	L	Z	Artikelcode	EUR
117	10	2,5	5	5	10	51	10	QBELET11710,00X2,50Z10	76.40
117	10	3	5	5	10	51	10	QBELET11710,00X3,00Z10	76.40

Weitere Abmessungen auf Anfrage lieferbar.

Schaftfräser für Chirurgie: T-Nutenformfräser HSS-E - Kat. 50100

Beschreibung:

T-Nutenformfräser aus HSS-E
"Stanzenfräser"

EKALINE®

Auf Wunsch mit Beschichtung lieferbar.

ACHTUNG: Auslaufartikel - lieferbar nur solange Vorrat

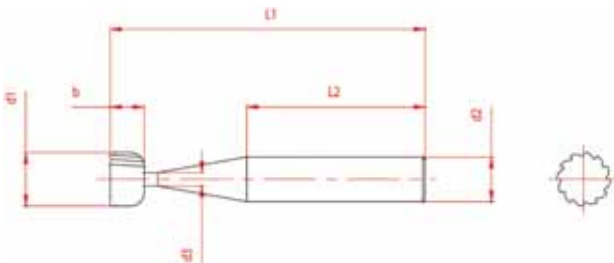

Typ	d1	b	R	d2	d3	l1	Artikel	EUR
50100	1,5	1,3	0,75	4	0,7	40	QEKALINE501001,5X1,3	28.20
50100	2,2	2	1,1	4	1,15	40	QEKALINE501002,2X2,0	29.57
50100	3,2	2,8	1,6	4	1,55	40	QEKALINE501003,2X2,8	28.71
50100	4,2	3	2,1	6	1,95	40	QEKALINE501004,2X3,0	28.29
50100	5,2	3,2	2,6	6	2,15	40	QEKALINE501005,2X3,2	27.14
50100	6,2	3,6	3,1	8	2,45	40	QEKALINE501006,2X3,6	31.57



Schaftfräser für Chirurgie: T-Nutenformfräser VHM - Kat. 117R

Beschreibung:

T-Nutenformfräser aus VHM
"Stanzenfräser"

Auf Wunsch mit Beschichtung lieferbar.

LB LOUIS BELET
Swiss cutting tools



Typ	d1	e	d2	l2	D	L	Z	Artikelcode	EUR
117R	2,2	2	1	2	6	38	8	QBELET117R2,20X2,00Z8	143.33
117R	3,2	2,8	1,5	2	6	38	8	QBELET117R3,20X2,80Z8	143.33
117R	4,2	3	2,5	3	6	38	8	QBELET117R4,20X3,00Z8	143.33
117R	5,2	3,2	3	3	6	38	8	QBELET117R5,20X3,20Z8	143.33
117R	6,2	3,6	3,5	4	6	38	8	QBELET117R6,20X3,60Z8	150.00



Schaftfräser für Chirurgie: T-Nutenfräser VHM mit Konvexradius - Kat. 117-2

Beschreibung:

T-Nutenfräser aus VHM

gerade Zahnung, mit konvexem Radius

Auf Wunsch mit Beschichtung lieferbar.

Weitere Abmessungen auf Anfrage lieferbar.



Typ	d1	e	r	d2	l2	D	L	Z	Artikelcode	EUR
117-2	4	0.4	0,2	1.5	3	4	38	4	QBELET11724,00X0,40	111.50
117-2	4	0.5	0,25	1.5	3	4	38	4	QBELET11724,00X0,50	111.50
117-2	4	0.6	0,3	1.5	3	4	38	4	QBELET11724,00X0,60	111.50
117-2	4	0.8	0,4	1.5	3	4	38	4	QBELET11724,00X0,80	111.50
117-2	4	1.0	0,5	1.5	3	4	38	4	QBELET11724,00X1,00	111.50
117-2	4	1.2	0,6	1.5	3	4	38	4	QBELET11724,00X1,20	111.50
117-2	4	1.5	0,75	1.5	3	4	38	4	QBELET11724,00X1,50	111.50
117-2	6	0.5	0,25	3	3.5	6	38	6	QBELET11726,00X0,50	122.10
117-2	6	0.6	0,3	3	3.5	6	38	6	QBELET11726,00X0,60	122.10
117-2	6	0.8	0,4	3	3.5	6	38	6	QBELET11726,00X0,80	122.10
117-2	6	1.0	0,5	3	3.5	6	38	6	QBELET11726,00X1,00	122.10
117-2	6	1.2	0,6	3	3.5	6	38	6	QBELET11726,00X1,20	122.10
117-2	6	1.5	0,75	3	3.5	6	38	6	QBELET11726,00X1,50	122.10
117-2	6	2.0	1	3	3.5	6	38	6	QBELET11726,00X2,00	122.10
117-2	8	1.0	0,5	4	4	8	51	6	QBELET11728,00X1,00	132.80
117-2	8	1.2	0,6	4	4	8	51	6	QBELET11728,00X1,20	132.80
117-2	8	1.5	0,75	4	4	8	51	6	QBELET11728,00X1,50	132.80
117-2	8	2.0	1	4	4	8	51	6	QBELET11728,00X2,00	132.80
117-2	8	2.5	1,25	4	4	8	51	6	QBELET11728,00X2,50	132.80
117-2	8	3.0	1,5	4	4	8	51	6	QBELET11728,00X3,00	132.80
117-2	10	1.0	0,5	5	5	10	51	8	QBELET117210,00X1,00	175.20
117-2	10	1.2	0,6	5	5	10	51	8	QBELET117210,00X1,20	175.20
117-2	10	1.5	0,75	5	5	10	51	8	QBELET117210,00X1,50	175.20
117-2	10	2.0	1	5	5	10	51	8	QBELET117210,00X2,00	175.20
117-2	10	2.5	1,25	5	5	10	51	8	QBELET117210,00X2,50	175.20
117-2	10	3.0	1,5	5	5	10	51	8	QBELET117210,00X3,00	175.20
117-2	10	4.0	2	5	5	10	51	8	QBELET117210,00X4,00	175.20



Schaftfräser für Chirurgie: Prismenfräser VHM 90 Grad - Kat. 117-3

Beschreibung:

Prismenfräser aus VHM

Spitzenwinkel 90 Grad

Auf Wunsch mit Beschichtung lieferbar.

Weitere Abmessungen auf Anfrage lieferbar.

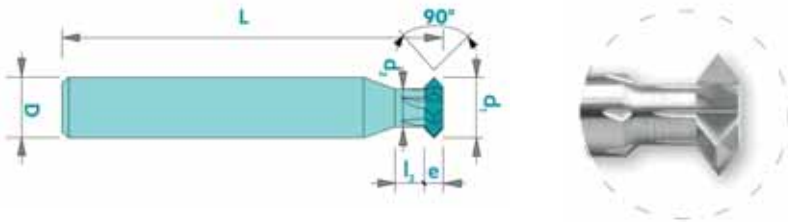

Weitere Abmessungen auf Anfrage lieferbar.

Typ	d1	e	d2	l2	D	L	Z	Artikelcode	EUR
117-3	3	0.5	1.5	3	3	38	5	QBELET11733,00X0,50	72.20
117-3	3	0.6	1.5	3	3	38	5	QBELET11733,00X0,60	72.20
117-3	3	0.8	1.5	3	3	38	5	QBELET11733,00X0,80	72.20
117-3	3	1.0	1.5	3	3	38	5	QBELET11733,00X1,00	72.20
117-3	4	0.5	2.5	3	4	38	5	QBELET11734,00X0,50	74.40
117-3	4	0.6	2.5	3	4	38	5	QBELET11734,00X0,60	74.40
117-3	4	0.8	2.5	3	4	38	5	QBELET11734,00X0,80	74.40
117-3	4	1.0	2.5	3	4	38	5	QBELET11734,00X1,00	74.40
117-3	4	1.2	2.5	3	4	38	5	QBELET11734,00X1,20	74.40
117-3	5	0.5	3.5	3	5	38	5	QBELET11735,00X0,50	76.40
117-3	5	0.6	3.5	3	5	38	5	QBELET11735,00X0,60	76.40
117-3	5	0.8	3.5	3	5	38	5	QBELET11735,00X0,80	76.40
117-3	5	1.0	3.5	3	5	38	5	QBELET11735,00X1,00	76.40
117-3	5	1.2	3.5	3	5	38	5	QBELET11735,00X1,20	76.40
117-3	6	1.0	4	3	6	38	6	QBELET11736,00X1,00	79.70
117-3	6	1.2	4	3	6	38	6	QBELET11736,00X1,20	79.70
117-3	6	1.5	4	3	6	38	6	QBELET11736,00X1,50	79.70
117-3	8	1.5	5.5	4	8	51	6	QBELET11738,00X1,50	90.30
117-3	8	2.0	5.5	4	8	51	6	QBELET11738,00X2,00	90.30
117-3	10	2.0	6.5	4	10	51	8	QBELET117310,00X2,00	100.90
117-3	10	2.5	6.5	4	10	51	8	QBELET117310,00X2,50	100.90
117-3	10	3.0	6.5	4	10	51	8	QBELET117310,00X3,00	100.90
117-3	10	3.5	6.5	4	10	51	8	QBELET117310,00X3,50	100.90
117-3	12	2.5	8	4	10	51	10	QBELET117312,00X2,50	138.10
117-3	12	3.0	8	4	10	51	10	QBELET117312,00X3,00	138.10



Typ	d1	e	d2	l2	D	L	Z	Artikelcode	EUR
117-3	12	3.5	8	4	10	51	10	QBELET117312,00X3,50	138.10
117-3	12	4.0	8	4	10	51	10	QBELET117312,00X4,00	138.10
117-3	16	3.0	-	-	10	61	12	QBELET117316,00X3,00	210.10
117-3	16	4.0	-	-	10	61	12	QBELET117316,00X4,00	210.10
117-3	16	5.0	-	-	10	61	12	QBELET117316,00X5,00	210.10

Schaftfräser für Chirurgie: Prismenfräser VHM 60 Grad - Kat. 117-4

Beschreibung:

Prismenfräser aus VHM

Spitzenwinkel 60 Grad

Auf Wunsch mit Beschichtung lieferbar.

Weitere Abmessungen auf Anfrage lieferbar.

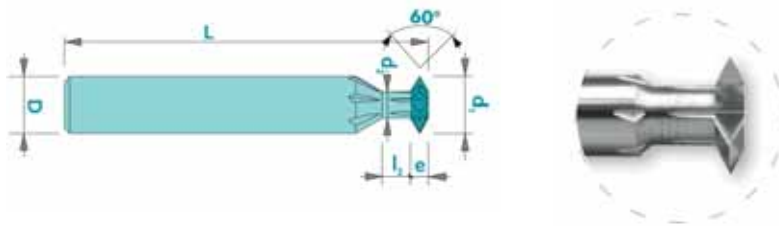

Typ	d1	e	d2	l2	D	L	Z	Artikelcode	EUR
117-4	5	0.5	2.1	3	5	38	5	QBELET11745,00X0,50	76.40
117-4	5	0.6	2.1	3	5	38	5	QBELET11745,00X0,60	76.40
117-4	5	0.8	2.1	3	5	38	5	QBELET11745,00X0,80	76.40
117-4	5	1.0	2.1	3	5	38	5	QBELET11745,00X1,00	76.40
117-4	5	1.2	2.1	3	5	38	5	QBELET11745,00X1,20	76.40
117-4	6	1.0	2.5	3	6	38	6	QBELET11746,00X1,00	79.70
117-4	6	1.2	2.5	3	6	38	6	QBELET11746,00X1,20	79.70
117-4	6	1.5	2.5	3	6	38	6	QBELET11746,00X1,50	79.70
117-4	8	1.5	3.6	4	8	51	6	QBELET11748,00X1,50	90.30
117-4	8	2.0	3.6	4	8	51	6	QBELET11748,00X2,00	90.30
117-4	10	2.0	4	4	10	51	6	QBELET117410,00X2,00	100.90
117-4	10	2.5	4	4	10	51	6	QBELET117410,00X2,50	100.90
117-4	10	3.0	4	4	10	51	6	QBELET117410,00X3,00	100.90
117-4	12	2.5	4.7	4	10	51	8	QBELET117412,00X2,50	138.10
117-4	12	3.0	4.7	4	10	51	8	QBELET117412,00X3,00	138.10
117-4	12	3.5	4.7	4	10	51	8	QBELET117412,00X3,50	138.10
117-4	16	3.0	7	4	10	61	12	QBELET117416,00X3,00	210.10
117-4	16	4.0	7	4	10	61	12	QBELET117416,00X4,00	210.10
117-4	16	5.0	7	4	10	61	12	QBELET117416,00X5,00	210.10



Schaftfräser für Chirurgie: Formfräser VHM mit konkavem Radius Kat. 118-0

Beschreibung:

Formfräser aus VHM
mit konkavem Radius



Auf Wunsch mit Beschichtung lieferbar.

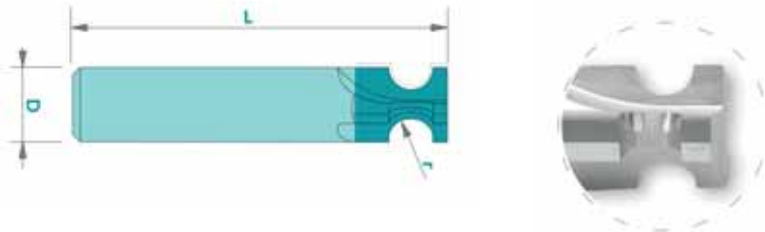

Weitere Abmessungen auf Anfrage lieferbar.

Typ	D	r	L	Z	Artikelcode	EUR
118-0	4	0.5	38	5	QBELET11804,00R0,50Z5	104.10
118-0	4	0.60	38	5	QBELET11804,00R0,60Z5	104.10
118-0	4	0.70	38	5	QBELET11804,00R0,70Z5	104.10
118-0	4	0.75	38	5	QBELET11804,00R0,75Z5	104.10
118-0	6	0.75	38	5	QBELET11806,00R0,75Z5	116.80
118-0	6	0.80	38	5	QBELET11806,00R0,80Z5	116.80
118-0	6	1.00	38	5	QBELET11806,00R1,00Z5	116.80
118-0	6	1.20	38	5	QBELET11806,00R1,20Z5	116.80
118-0	6	1.25	38	5	QBELET11806,00R1,25Z5	116.80
118-0	8	1.00	51	5	QBELET11808,00R1,00Z5	138.10
118-0	8	1.20	51	5	QBELET11808,00R1,20Z5	138.10
118-0	8	1.25	51	5	QBELET11808,00R1,25Z5	138.10
118-0	8	1.50	51	5	QBELET11808,00R1,50Z5	138.10
118-0	8	1.75	51	5	QBELET11808,00R1,75Z5	138.10
118-0	8	2.00	51	5	QBELET11808,00R2,00Z5	138.10
118-0	10	2.00	51	5	QBELET118010,00R2,00Z5	159.20
118-0	10	2.25	51	5	QBELET118010,00R2,25Z5	159.20
118-0	10	2.50	51	5	QBELET118010,00R2,50Z5	159.20
118-0	10	3.00	51	5	QBELET118010,00R3,00Z5	159.20



Schaftfräser für Chirurgie: Schwalbenschwanzfräser VHM 45 Grad - Kat. 118-1

Beschreibung:

Schwalbenschwanzfräser aus VHM
Winkel 45 Grad

Auf Wunsch mit Beschichtung lieferbar.

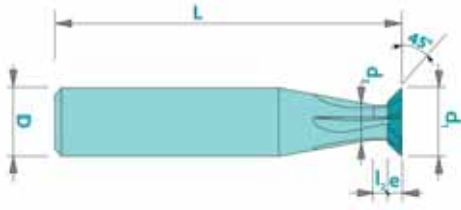

Weitere Abmessungen auf Anfrage lieferbar.

Typ	d1	e	D	L	Z	Artikelcode	EUR
118-1	1	0.2	3	38	3	QBELET11811,00X0,20Z3	69.10
118-1	1	0.3	3	38	3	QBELET11811,00X0,30Z3	69.10
118-1	1.5	0.3	3	38	3	QBELET11811,50X0,30Z3	69.10
118-1	1.5	0.4	3	38	3	QBELET11811,50X0,40Z3	69.10
118-1	2	0.3	3	38	5	QBELET11812,00X0,30Z5	69.10
118-1	2	0.4	3	38	5	QBELET11812,00X0,40Z5	69.10
118-1	2	0.5	3	38	5	QBELET11812,00X0,50Z5	69.10
118-1	3	0.5	3	38	5	QBELET11813,00X0,50Z5	69.10
118-1	3	0.6	3	38	5	QBELET11813,00X0,60Z5	69.10
118-1	3	0.7	3	38	5	QBELET11813,00X0,70Z5	69.10
118-1	4	0.8	4	38	5	QBELET11814,00X0,80Z5	74.40
118-1	4	1	4	38	5	QBELET11814,00X1,00Z5	74.40
118-1	4	1.2	4	38	5	QBELET11814,00X1,20Z5	74.40
118-1	5	1	5	38	5	QBELET11815,00X1,00Z5	79.70

Typ	d1	e	D	L	Z	Artikelcode	EUR
118-1	5	1.2	5	38	5	QBELET11815,00X1,20Z5	79.70
118-1	5	1.5	5	38	5	QBELET11815,00X1,50Z5	79.70
118-1	6	1	6	38	5	QBELET11816,00X1,00Z5	85.00
118-1	6	1.2	6	38	5	QBELET11816,00X1,20Z5	85.00
118-1	6	1.5	6	38	5	QBELET11816,00X1,50Z5	85.00
118-1	6	2	6	38	5	QBELET11816,00X2,00Z5	85.00
118-1	8	1.5	8	51	5	QBELET11818,00X1,50Z5	90.30
118-1	8	2	8	51	5	QBELET11818,00X2,00Z5	90.30
118-1	8	2.5	8	51	5	QBELET11818,00X2,50Z5	90.30
118-1	10	2	10	51	5	QBELET118110,00X2,00Z5	116.80
118-1	10	2.5	10	51	5	QBELET118110,00X2,50Z5	116.80
118-1	10	3	10	51	5	QBELET118110,00X3,00Z5	116.80
118-1	10	3.5	10	51	5	QBELET118110,00X3,50Z5	116.80



Schaftfräser für Chirurgie: Schwalbenschwanzfräser VHM 60 Grad - Kat. 118-2

Beschreibung:

Schwalbenschwanzfräser aus VHM
Winkel 60 Grad

Auf Wunsch mit Beschichtung lieferbar.

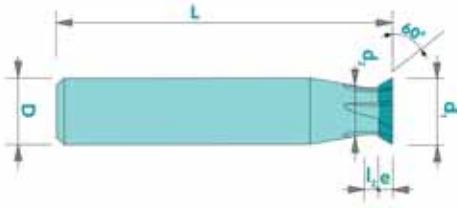

Weitere Abmessungen auf Anfrage lieferbar.

Typ	d1	e	D	L	Z	Artikelcode	EUR
118-2	1	0,2	3	38	3	QBELET11821,00X0,20	69.10
118-2	1	0,3	3	38	3	QBELET11821,00X0,30	69.10
118-2	1,5	0,3	3	38	3	QBELET11821,50X0,30	69.10
118-2	1,5	0,4	3	38	3	QBELET11821,50X0,40	69.10
118-2	1,5	0,5	3	38	3	QBELET11821,50X0,50	69.10
118-2	2	0,4	3	38	5	QBELET11822,00X0,40	69.10
118-2	2	0,5	3	38	5	QBELET11822,00X0,50	69.10
118-2	2	0,7	3	38	5	QBELET11822,00X0,70	69.10
118-2	3	0,5	3	38	5	QBELET11823,00X0,50	69.10
118-2	3	0,7	3	38	5	QBELET11823,00X0,70	69.10
118-2	3	1	3	38	5	QBELET11823,00X1,00	69.10
118-2	4	0,8	4	38	5	QBELET11824,00X0,80	79.70
118-2	4	1	4	38	5	QBELET11824,00X1,00	79.70
118-2	4	1,5	4	38	5	QBELET11824,00X1,50	79.70
118-2	4	2	4	38	5	QBELET11824,00X2,00	79.70
118-2	5	1	5	38	5	QBELET11825,00X1,00	85.00
118-2	5	1,5	5	38	5	QBELET11825,00X1,50	85.00

Typ	d1	e	D	L	Z	Artikelcode	EUR
118-2	5	2	5	38	5	QBELET11825,00X2,00	85.00
118-2	5	2,5	5	38	5	QBELET11825,00X2,50	85.00
118-2	6	1	6	38	5	QBELET11826,00X1,00	90.30
118-2	6	1,5	6	38	5	QBELET11826,00X1,50	90.30
118-2	6	2	6	38	5	QBELET11826,00X2,00	90.30
118-2	6	2,5	6	38	5	QBELET11826,00X2,50	90.30
118-2	6	3	6	38	5	QBELET11826,00X3,00	90.30
118-2	8	1,5	8	51	5	QBELET11828,00X1,50	100.90
118-2	8	2	8	51	5	QBELET11828,00X2,00	100.90
118-2	8	2,5	8	51	5	QBELET11828,00X2,50	100.90
118-2	8	3	8	51	5	QBELET11828,00X3,00	100.90
118-2	8	4	8	51	5	QBELET11828,00X4,00	100.90
118-2	10	2	10	51	5	QBELET118210,00X2,00	127.40
118-2	10	3	10	51	5	QBELET118210,00X3,00	127.40
118-2	10	4	10	51	5	QBELET118210,00X4,00	127.40
118-2	10	5	10	51	5	QBELET118210,00X5,00	127.40



Schaftfräser für Chirurgie: Viertelkreisfräser VHM mit konkavem Radius - Kat. 118

Beschreibung:

Viertelkreisfräser aus VHM
mit konkavem Radius



Auf Wunsch mit Beschichtung lieferbar.

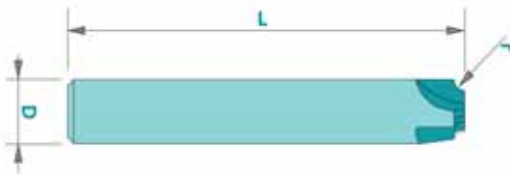

Weitere Abmessungen auf Anfrage lieferbar.

Typ	D	r	L	Z	Artikelcode	EUR
118	2	0.1	33	Z5	QBELET1182,00R0,10Z5	52.10
118	2	0.2	33	Z5	QBELET1182,00R0,20Z5	52.10
118	2	0.3	33	Z5	QBELET1182,00R0,30Z5	52.10
118	3	0.1	38	Z5	QBELET1183,00R0,10Z5	52.10
118	3	0.2	38	Z5	QBELET1183,00R0,20Z5	52.10
118	3	0.3	38	Z5	QBELET1183,00R0,30Z5	52.10
118	3	0.4	38	Z5	QBELET1183,00R0,40Z5	52.10
118	3	0.5	38	Z5	QBELET1183,00R0,50Z5	52.10
118	4	0.5	38	Z5	QBELET1184,00R0,50Z5	62.70
118	4	0.6	38	Z5	QBELET1184,00R0,60Z5	62.70
118	4	0.7	38	Z5	QBELET1184,00R0,70Z5	62.70
118	4	0.8	38	Z5	QBELET1184,00R0,80Z5	62.70
118	4	0.9	38	Z5	QBELET1184,00R0,90Z5	62.70
118	4	1	38	Z5	QBELET1184,00R1,00Z5	62.70
118	6	0.75	38	Z5	QBELET1186,00R0,75Z5	79.70

Typ	D	r	L	Z	Artikelcode	EUR
118	6	0.8	38	Z5	QBELET1186,00R0,80Z5	79.70
118	6	1	38	Z5	QBELET1186,00R1,00Z5	79.70
118	6	1.2	38	Z5	QBELET1186,00R1,20Z5	79.70
118	6	1.5	38	Z5	QBELET1186,00R1,50Z5	79.70
118	6	2	38	Z5	QBELET1186,00R2,00Z5	79.70
118	8	1	51	Z5	QBELET1188,00R1,00Z5	90.30
118	8	1.5	51	Z5	QBELET1188,00R1,50Z5	90.30
118	8	2	51	Z5	QBELET1188,00R2,00Z5	90.30
118	8	2.5	51	Z5	QBELET1188,00R2,50Z5	90.30
118	10	1.5	51	Z5	QBELET11810,00R1,50Z5	116.80
118	10	2	51	Z5	QBELET11810,00R2,00Z5	116.80
118	10	2.5	51	Z5	QBELET11810,00R2,50Z5	116.80
118	10	3	51	Z5	QBELET11810,00R3,00Z5	116.80
118	10	3.5	51	Z5	QBELET11810,00R3,50Z5	116.80



VHM Kreissägen: VHM Kreissägen Typ 101 feine Verzahnung

Beschreibung:

Vollhartmetall-Kreissägeblätter DIN 1837
feine Verzahnung

EKALINE®

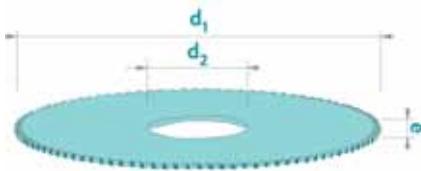

Typ	D js15	E +/- 0,01	d H7	Z	Artikel	EUR
101	15	0,1	5	64	QVHMMKA10115X0,10X5	15.20
101	15	0,15	5	64	QVHMMKA10115X0,15X5	12.60
101	15	0,2	5	64	QVHMMKA10115X0,20X5	8.70
101	15	0,25	5	64	QVHMMKA10115X0,25X5	8.70
101	15	0,3	5	64	QVHMMKA10115X0,30X5	8.70
101	15	0,35	5	64	QVHMMKA10115X0,35X5	8.70
101	15	0,4	5	64	QVHMMKA10115X0,40X5	8.70
101	15	0,5	5	48	QVHMMKA10115X0,50X5	9.90
101	15	0,6	5	48	QVHMMKA10115X0,60X5	9.90
101	15	0,7	5	48	QVHMMKA10115X0,70X5	11.60
101	15	0,8	5	40	QVHMMKA10115X0,80X5	11.60
101	15	0,9	5	40	QVHMMKA10115X0,90X5	12.10
101	15	1	5	40	QVHMMKA10115X1,00X5	12.60
101	15	1,1	5	40	QVHMMKA10115X1,10X5	13.00
101	15	1,2	5	40	QVHMMKA10115X1,20X5	13.00
101	15	1,3	5	40	QVHMMKA10115X1,30X5	13.50
101	15	1,4	5	40	QVHMMKA10115X1,40X5	13.50
101	15	1,5	5	40	QVHMMKA10115X1,50X5	14.40
101	15	1,6	5	40	QVHMMKA10115X1,60X5	15.20
101	15	1,7	5	40	QVHMMKA10115X1,70X5	16.60
101	15	1,8	5	40	QVHMMKA10115X1,80X5	16.60
101	15	1,9	5	40	QVHMMKA10115X1,90X5	17.40
101	15	2	5	40	QVHMMKA10115X2,00X5	17.40
101	15	2,5	5	40	QVHMMKA10115X2,50X5	24.10
101	15	3	5	40	QVHMMKA10115X3,00X5	27.30
101	15	4	5	24	QVHMMKA10115X4,00X5	37.80
101	15	5	5	24	QVHMMKA10115X5,00X5	46.20
101	15	6	5	24	QVHMMKA10115X6,00X5	56.90
101	20	0,15	5	80	QVHMMKA10120X0,15X5	13.50

Typ	D js15	E +/- 0,01	d H7	Z	Artikel	EUR
101	20	0,2	5	80	QVHMMKA10120X0,20X5	9.90
101	20	0,25	5	64	QVHMMKA10120X0,25X5	9.90
101	20	0,3	5	64	QVHMMKA10120X0,30X5	9.90
101	20	0,35	5	64	QVHMMKA10120X0,35X5	9.90
101	20	0,4	5	64	QVHMMKA10120X0,40X5	9.90
101	20	0,5	5	48	QVHMMKA10120X0,50X5	10.80
101	20	0,6	5	48	QVHMMKA10120X0,60X5	10.80
101	20	0,7	5	48	QVHMMKA10120X0,70X5	12.60
101	20	0,8	5	48	QVHMMKA10120X0,80X5	12.60
101	20	0,9	5	40	QVHMMKA10120X0,90X5	13.00
101	20	1	5	40	QVHMMKA10120X1,00X5	14.40
101	20	1,1	5	40	QVHMMKA10120X1,10X5	15.20
101	20	1,2	5	40	QVHMMKA10120X1,20X5	15.20
101	20	1,3	5	40	QVHMMKA10120X1,30X5	16.20
101	20	1,4	5	40	QVHMMKA10120X1,40X5	17.40
101	20	1,5	5	40	QVHMMKA10120X1,50X5	17.40
101	20	1,6	5	40	QVHMMKA10120X1,60X5	18.30
101	20	1,7	5	40	QVHMMKA10120X1,70X5	19.20
101	20	1,8	5	32	QVHMMKA10120X1,80X5	19.20
101	20	1,9	5	32	QVHMMKA10120X1,90X5	20.20
101	20	2	5	32	QVHMMKA10120X2,00X5	20.20
101	20	2,5	5	32	QVHMMKA10120X2,50X5	25.50
101	20	3	5	32	QVHMMKA10120X3,00X5	28.90
101	20	3,5	5	24	QVHMMKA10120X3,50X5	30.70
101	20	4	5	24	QVHMMKA10120X4,00X5	38.80
101	20	5	5	24	QVHMMKA10120X5,00X5	48.10
101	20	6	5	24	QVHMMKA10120X6,00X5	57.70
101	25	0,1	8	80	QVHMMKA10125X0,10X8	19.20
101	25	0,15	8	80	QVHMMKA10125X0,15X8	15.20



Typ	D js15	E +/- 0,01	d H7	Z	Artikel	EUR
101	25	0,2	8	80	QVHMMKA10125X0,20X8	10.80
101	25	0,25	8	80	QVHMMKA10125X0,25X8	10.80
101	25	0,3	8	80	QVHMMKA10125X0,30X8	10.80
101	25	0,35	8	64	QVHMMKA10125X0,35X8	10.80
101	25	0,4	8	64	QVHMMKA10125X0,40X8	11.20
101	25	0,5	8	64	QVHMMKA10125X0,50X8	12.60
101	25	0,6	8	64	QVHMMKA10125X0,60X8	13.00
101	25	0,7	8	48	QVHMMKA10125X0,70X8	14.40
101	25	0,8	8	48	QVHMMKA10125X0,80X8	16.20
101	25	0,9	8	48	QVHMMKA10125X0,90X8	17.40
101	25	1	8	48	QVHMMKA10125X1,00X8	17.40
101	25	1,1	8	48	QVHMMKA10125X1,10X8	20.20
101	25	1,2	8	48	QVHMMKA10125X1,20X8	20.20
101	25	1,3	8	40	QVHMMKA10125X1,30X8	21.00
101	25	1,4	8	40	QVHMMKA10125X1,40X8	21.90
101	25	1,5	8	40	QVHMMKA10125X1,50X8	21.90
101	25	1,6	8	40	QVHMMKA10125X1,60X8	24.10
101	25	1,7	8	40	QVHMMKA10125X1,70X8	24.10
101	25	1,8	8	40	QVHMMKA10125X1,80X8	25.00
101	25	1,9	8	40	QVHMMKA10125X1,90X8	26.70
101	25	2	8	40	QVHMMKA10125X2,00X8	27.70
101	25	2,5	8	40	QVHMMKA10125X2,50X8	33.40
101	25	3	8	32	QVHMMKA10125X3,00X8	43.60
101	25	3,5	8	32	QVHMMKA10125X3,50X8	48.10
101	25	4	8	32	QVHMMKA10125X4,00X8	54.40
101	25	5	8	32	QVHMMKA10125X5,00X8	65.90
101	25	6	8	24	QVHMMKA10125X6,00X8	78.20
101	30	0,1	8	100	QVHMMKA10130X0,10X8	22.80
101	30	0,15	8	100	QVHMMKA10130X0,15X8	16.20
101	30	0,2	8	100	QVHMMKA10130X0,20X8	14.40
101	30	0,25	8	100	QVHMMKA10130X0,25X8	14.40
101	30	0,3	8	80	QVHMMKA10130X0,30X8	14.40
101	30	0,35	8	80	QVHMMKA10130X0,35X8	14.40
101	30	0,4	8	80	QVHMMKA10130X0,40X8	14.40
101	30	0,5	8	80	QVHMMKA10130X0,50X8	15.20
101	30	0,6	8	64	QVHMMKA10130X0,60X8	15.20
101	30	0,7	8	64	QVHMMKA10130X0,70X8	18.30
101	30	0,8	8	64	QVHMMKA10130X0,80X8	20.20
101	30	0,9	8	64	QVHMMKA10130X0,90X8	21.90
101	30	1	8	64	QVHMMKA10130X1,00X8	21.90
101	30	1,1	8	64	QVHMMKA10130X1,10X8	24.60
101	30	1,2	8	48	QVHMMKA10130X1,20X8	25.00

Typ	D js15	E +/- 0,01	d H7	Z	Artikel	EUR
101	30	1,3	8	48	QVHMMKA10130X1,30X8	25.90
101	30	1,4	8	48	QVHMMKA10130X1,40X8	28.20
101	30	1,5	8	48	QVHMMKA10130X1,50X8	28.20
101	30	1,6	8	48	QVHMMKA10130X1,60X8	29.80
101	30	1,7	8	48	QVHMMKA10130X1,70X8	29.80
101	30	1,8	8	48	QVHMMKA10130X1,80X8	30.70
101	30	1,9	8	48	QVHMMKA10130X1,90X8	31.70
101	30	2	8	48	QVHMMKA10130X2,00X8	32.50
101	30	2,5	8	40	QVHMMKA10130X2,50X8	38.20
101	30	3	8	40	QVHMMKA10130X3,00X8	45.40
101	30	3,5	8	40	QVHMMKA10130X3,50X8	51.70
101	30	4	8	40	QVHMMKA10130X4,00X8	57.70
101	30	5	8	32	QVHMMKA10130X5,00X8	70.30
101	30	6	8	32	QVHMMKA10130X6,00X8	82.70
101	40	0,1	10	128	QVHMMKA10140X0,10X10	25.50
101	40	0,15	10	128	QVHMMKA10140X0,15X10	21.00
101	40	0,2	10	128	QVHMMKA10140X0,20X10	18.30
101	40	0,25	10	100	QVHMMKA10140X0,25X10	18.30
101	40	0,3	10	100	QVHMMKA10140X0,30X10	18.30
101	40	0,35	10	100	QVHMMKA10140X0,35X10	18.30
101	40	0,4	10	100	QVHMMKA10140X0,40X10	19.20
101	40	0,5	10	80	QVHMMKA10140X0,50X10	21.00
101	40	0,6	10	80	QVHMMKA10140X0,60X10	21.00
101	40	0,7	10	80	QVHMMKA10140X0,70X10	24.10
101	40	0,8	10	80	QVHMMKA10140X0,80X10	25.00
101	40	0,9	10	64	QVHMMKA10140X0,90X10	25.00
101	40	1	10	64	QVHMMKA10140X1,00X10	25.90
101	40	1,1	10	64	QVHMMKA10140X1,10X10	26.70
101	40	1,2	10	64	QVHMMKA10140X1,20X10	27.70
101	40	1,3	10	64	QVHMMKA10140X1,30X10	27.70
101	40	1,4	10	64	QVHMMKA10140X1,40X10	29.80
101	40	1,5	10	64	QVHMMKA10140X1,50X10	30.70
101	40	1,6	10	64	QVHMMKA10140X1,60X10	31.70
101	40	1,7	10	48	QVHMMKA10140X1,70X10	33.40
101	40	1,8	10	48	QVHMMKA10140X1,80X10	34.30
101	40	1,9	10	48	QVHMMKA10140X1,90X10	35.20
101	40	2	10	48	QVHMMKA10140X2,00X10	35.20
101	40	2,5	10	48	QVHMMKA10140X2,50X10	45.40
101	40	3	10	48	QVHMMKA10140X3,00X10	52.50
101	40	3,5	10	48	QVHMMKA10140X3,50X10	58.70
101	40	4	10	40	QVHMMKA10140X4,00X10	64.90
101	40	5	10	40	QVHMMKA10140X5,00X10	78.20



Typ	D js15	E +/- 0,01	d H7	Z	Artikel	EUR
101	40	6	10	40	QVHMMKA10140X6,00X10	92.30
101	50	0,2	13	128	QVHMMKA10150X0,20X13	29.80
101	50	0,25	13	128	QVHMMKA10150X0,25X13	28.90
101	50	0,3	13	128	QVHMMKA10150X0,30X13	24.60
101	50	0,35	13	100	QVHMMKA10150X0,35X13	24.60
101	50	0,4	13	100	QVHMMKA10150X0,40X13	24.60
101	50	0,5	13	100	QVHMMKA10150X0,50X13	25.50
101	50	0,6	13	100	QVHMMKA10150X0,60X13	25.50
101	50	0,7	13	80	QVHMMKA10150X0,70X13	26.70
101	50	0,8	13	80	QVHMMKA10150X0,80X13	28.90
101	50	0,9	13	80	QVHMMKA10150X0,90X13	29.80
101	50	1	13	80	QVHMMKA10150X1,00X13	30.70
101	50	1,1	13	80	QVHMMKA10150X1,10X13	31.70
101	50	1,2	13	80	QVHMMKA10150X1,20X13	32.50
101	50	1,3	13	64	QVHMMKA10150X1,30X13	36.60
101	50	1,4	13	64	QVHMMKA10150X1,40X13	37.50
101	50	1,5	13	64	QVHMMKA10150X1,50X13	39.20
101	50	1,6	13	64	QVHMMKA10150X1,60X13	40.10
101	50	1,7	13	64	QVHMMKA10150X1,70X13	40.50
101	50	1,8	13	64	QVHMMKA10150X1,80X13	43.30
101	50	1,9	13	64	QVHMMKA10150X1,90X13	43.30
101	50	2	13	64	QVHMMKA10150X2,00X13	44.50
101	50	2,5	13	64	QVHMMKA10150X2,50X13	54.40
101	50	3	13	48	QVHMMKA10150X3,00X13	63.20
101	50	3,5	13	48	QVHMMKA10150X3,50X13	72.10
101	50	4	13	48	QVHMMKA10150X4,00X13	76.40

Typ	D js15	E +/- 0,01	d H7	Z	Artikel	EUR
101	50	5	13	48	QVHMMKA10150X5,00X13	93.30
101	50	6	13	40	QVHMMKA10150X6,00X13	108.50
101	63	0,2	16	160	QVHMMKA10163X0,20X16	45.40
101	63	0,25	16	160	QVHMMKA10163X0,25X16	43.60
101	63	0,3	16	128	QVHMMKA10163X0,30X16	40.50
101	63	0,35	16	128	QVHMMKA10163X0,35X16	38.20
101	63	0,4	16	128	QVHMMKA10163X0,40X16	34.70
101	63	0,5	16	128	QVHMMKA10163X0,50X16	33.90
101	63	0,6	16	100	QVHMMKA10163X0,60X16	34.70
101	63	0,7	16	100	QVHMMKA10163X0,70X16	39.20
101	63	0,8	16	100	QVHMMKA10163X0,80X16	43.30
101	63	0,9	16	100	QVHMMKA10163X0,90X16	43.60
101	63	1	16	100	QVHMMKA10163X1,00X16	44.50
101	63	1,1	16	80	QVHMMKA10163X1,10X16	46.20
101	63	1,2	16	80	QVHMMKA10163X1,20X16	48.10
101	63	1,3	16	80	QVHMMKA10163X1,30X16	49.00
101	63	1,4	16	80	QVHMMKA10163X1,40X16	49.80
101	63	1,5	16	80	QVHMMKA10163X1,50X16	50.80
101	63	1,6	16	80	QVHMMKA10163X1,60X16	53.40
101	63	1,7	16	80	QVHMMKA10163X1,70X16	56.00
101	63	1,8	16	80	QVHMMKA10163X1,80X16	56.90
101	63	1,9	16	80	QVHMMKA10163X1,90X16	59.60
101	63	2	16	80	QVHMMKA10163X2,00X16	61.30
101	63	2,5	16	64	QVHMMKA10163X2,50X16	73.90
101	63	3	16	64	QVHMMKA10163X3,00X16	83.60

Weiter Abmessungen auf Anfrage lieferbar.



VHM Kreissägen: VHM Kreissägen Typ 102 grobe Verzahnung

Beschreibung:

Vollhartmetall-Kreissägeblätter DIN 1837
grobe Verzahnung

EKALINE®

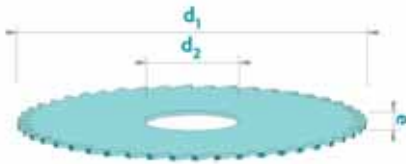

Typ	D js15	E +/- 0,01	d H7	Z	Artikelcode	EUR
102	15	0,2	5	20	QVHMMKA10215X0,20X5	8.70
102	15	0,25	5	20	QVHMMKA10215X0,25X5	8.70
102	15	0,3	5	20	QVHMMKA10215X0,30X5	8.70
102	15	0,35	5	20	QVHMMKA10215X0,35X5	8.70
102	15	0,4	5	20	QVHMMKA10215X0,40X5	8.70
102	15	0,5	5	20	QVHMMKA10215X0,50X5	9.90
102	15	0,6	5	20	QVHMMKA10215X0,60X5	9.90
102	15	0,7	5	20	QVHMMKA10215X0,70X5	11.60
102	15	0,8	5	20	QVHMMKA10215X0,80X5	11.60
102	15	0,9	5	20	QVHMMKA10215X0,90X5	12.10
102	15	1	5	20	QVHMMKA10215X1,00X5	12.60
102	15	1,1	5	20	QVHMMKA10215X1,10X5	13.00
102	15	1,2	5	20	QVHMMKA10215X1,20X5	13.00
102	15	1,3	5	20	QVHMMKA10215X1,30X5	13.50
102	15	1,4	5	20	QVHMMKA10215X1,40X5	13.50
102	15	1,5	5	20	QVHMMKA10215X1,50X5	14.40
102	15	1,6	5	20	QVHMMKA10215X1,60X5	15.20
102	15	1,7	5	20	QVHMMKA10215X1,70X5	16.60
102	15	1,8	5	20	QVHMMKA10215X1,80X5	16.60
102	15	1,9	5	20	QVHMMKA10215X1,90X5	17.40
102	15	2	5	20	QVHMMKA10215X2,00X5	17.40
102	15	2,5	5	20	QVHMMKA10215X2,50X5	24.10
102	15	3	5	20	QVHMMKA10215X3,00X5	27.30
102	15	4	5	20	QVHMMKA10215X4,00X5	37.80
102	15	5	5	20	QVHMMKA10215X5,00X5	46.20
102	15	6	5	20	QVHMMKA10215X6,00X5	56.90
102	20	0,2	5	20	QVHMMKA10220X0,20X5	9.90
102	20	0,25	5	20	QVHMMKA10220X0,25X5	9.90
102	20	0,3	5	20	QVHMMKA10220X0,30X5	9.90

Typ	D js15	E +/- 0,01	d H7	Z	Artikelcode	EUR
102	20	0,35	5	20	QVHMMKA10220X0,35X5	9.90
102	20	0,4	5	20	QVHMMKA10220X0,40X5	9.90
102	20	0,5	5	20	QVHMMKA10220X0,50X5	10.80
102	20	0,6	5	20	QVHMMKA10220X0,60X5	10.80
102	20	0,7	5	20	QVHMMKA10220X0,70X5	12.60
102	20	0,8	5	20	QVHMMKA10220X0,80X5	12.60
102	20	0,9	5	20	QVHMMKA10220X0,90X5	13.00
102	20	1	5	20	QVHMMKA10220X1,00X5	14.40
102	20	1,1	5	20	QVHMMKA10220X1,10X5	15.20
102	20	1,2	5	20	QVHMMKA10220X1,20X5	15.20
102	20	1,3	5	20	QVHMMKA10220X1,30X5	16.20
102	20	1,4	5	20	QVHMMKA10220X1,40X5	17.40
102	20	1,5	5	20	QVHMMKA10220X1,50X5	17.40
102	20	1,6	5	20	QVHMMKA10220X1,60X5	18.30
102	20	1,7	5	20	QVHMMKA10220X1,70X5	19.20
102	20	1,8	5	20	QVHMMKA10220X1,80X5	19.20
102	20	1,9	5	20	QVHMMKA10220X1,90X5	20.20
102	20	2	5	20	QVHMMKA10220X2,00X5	20.20
102	20	2,5	5	20	QVHMMKA10220X2,50X5	25.50
102	20	3	5	20	QVHMMKA10220X3,00X5	28.90
102	20	3,5	5	20	QVHMMKA10220X3,50X5	30.70
102	20	4	5	20	QVHMMKA10220X4,00X5	38.80
102	20	5	5	20	QVHMMKA10220X5,00X5	48.10
102	20	6	5	20	QVHMMKA10220X6,00X5	57.70
102	25	0,2	8	20	QVHMMKA10225X0,20X8	10.80
102	25	0,25	8	20	QVHMMKA10225X0,25X8	10.80
102	25	0,3	8	20	QVHMMKA10225X0,30X8	10.80
102	25	0,35	8	20	QVHMMKA10225X0,35X8	10.80
102	25	0,4	8	20	QVHMMKA10225X0,40X8	11.20



Typ	D js15	E +/- 0,01	d H7	Z	Artikelcode	EUR
102	25	0,5	8	20	QVHMMKA10225X0,50X8	12.60
102	25	0,6	8	20	QVHMMKA10225X0,60X8	13.00
102	25	0,7	8	20	QVHMMKA10225X0,70X8	14.40
102	25	0,8	8	20	QVHMMKA10225X0,80X8	16.20
102	25	0,9	8	20	QVHMMKA10225X0,90X8	17.40
102	25	1	8	20	QVHMMKA10225X1,00X8	17.40
102	25	1,1	8	20	QVHMMKA10225X1,10X8	20.20
102	25	1,2	8	20	QVHMMKA10225X1,20X8	20.20
102	25	1,3	8	20	QVHMMKA10225X1,30X8	21.00
102	25	1,4	8	20	QVHMMKA10225X1,40X8	21.90
102	25	1,5	8	20	QVHMMKA10225X1,50X8	21.90
102	25	1,6	8	20	QVHMMKA10225X1,60X8	24.10
102	25	1,7	8	20	QVHMMKA10225X1,70X8	24.10
102	25	1,8	8	20	QVHMMKA10225X1,80X8	25.00
102	25	1,9	8	20	QVHMMKA10225X1,90X8	26.70
102	25	2	8	20	QVHMMKA10225X2,00X8	27.70
102	25	2,5	8	20	QVHMMKA10225X2,50X8	33.40
102	25	3	8	20	QVHMMKA10225X3,00X8	43.60
102	25	3,5	8	20	QVHMMKA10225X3,50X8	48.10
102	25	4	8	20	QVHMMKA10225X4,00X8	54.40
102	25	5	8	20	QVHMMKA10225X5,00X8	65.90
102	25	6	8	20	QVHMMKA10225X6,00X8	78.20
102	30	0,2	8	30	QVHMMKA10230X0,20X8	14.40
102	30	0,25	8	30	QVHMMKA10230X0,25X8	14.40
102	30	0,3	8	30	QVHMMKA10230X0,30X8	14.40
102	30	0,35	8	30	QVHMMKA10230X0,35X8	14.40
102	30	0,4	8	30	QVHMMKA10230X0,40X8	14.40
102	30	0,5	8	30	QVHMMKA10230X0,50X8	15.20
102	30	0,6	8	30	QVHMMKA10230X0,60X8	15.20
102	30	0,7	8	30	QVHMMKA10230X0,70X8	18.30
102	30	0,8	8	24	QVHMMKA10230X0,80X8	20.20
102	30	0,9	8	24	QVHMMKA10230X0,90X8	21.90
102	30	1	8	24	QVHMMKA10230X1,00X8	21.90
102	30	1,1	8	24	QVHMMKA10230X1,10X8	24.60
102	30	1,2	8	24	QVHMMKA10230X1,20X8	25.00
102	30	1,3	8	24	QVHMMKA10230X1,30X8	25.90
102	30	1,4	8	24	QVHMMKA10230X1,40X8	28.20
102	30	1,5	8	24	QVHMMKA10230X1,50X8	28.20
102	30	1,6	8	24	QVHMMKA10230X1,60X8	29.80
102	30	1,7	8	24	QVHMMKA10230X1,70X8	29.80
102	30	1,8	8	24	QVHMMKA10230X1,80X8	30.70
102	30	1,9	8	24	QVHMMKA10230X1,90X8	31.70

Typ	D js15	E +/- 0,01	d H7	Z	Artikelcode	EUR
102	30	2	8	24	QVHMMKA10230X2,00X8	32.50
102	30	2,5	8	24	QVHMMKA10230X2,50X8	38.20
102	30	3	8	24	QVHMMKA10230X3,00X8	45.40
102	30	3,5	8	24	QVHMMKA10230X3,50X8	51.70
102	30	4	8	24	QVHMMKA10230X4,00X8	57.70
102	30	5	8	24	QVHMMKA10230X5,00X8	70.30
102	30	6	8	24	QVHMMKA10230X6,00X8	82.70
102	40	0,2	10	40	QVHMMKA10240X0,20X10	18.30
102	40	0,25	10	40	QVHMMKA10240X0,25X10	18.30
102	40	0,3	10	40	QVHMMKA10240X0,30X10	18.30
102	40	0,35	10	40	QVHMMKA10240X0,35X10	18.30
102	40	0,4	10	40	QVHMMKA10240X0,40X10	19.20
102	40	0,5	10	40	QVHMMKA10240X0,50X10	21.00
102	40	0,6	10	40	QVHMMKA10240X0,60X10	21.00
102	40	0,7	10	40	QVHMMKA10240X0,70X10	24.10
102	40	0,8	10	32	QVHMMKA10240X0,80X10	25.00
102	40	0,9	10	32	QVHMMKA10240X0,90X10	25.00
102	40	1	10	32	QVHMMKA10240X1,00X10	25.90
102	40	1,1	10	32	QVHMMKA10240X1,10X10	26.70
102	40	1,2	10	32	QVHMMKA10240X1,20X10	27.70
102	40	1,3	10	32	QVHMMKA10240X1,30X10	27.70
102	40	1,4	10	32	QVHMMKA10240X1,40X10	29.80
102	40	1,5	10	32	QVHMMKA10240X1,50X10	30.70
102	40	1,6	10	32	QVHMMKA10240X1,60X10	31.70
102	40	1,7	10	32	QVHMMKA10240X1,70X10	33.40
102	40	1,8	10	32	QVHMMKA10240X1,80X10	34.30
102	40	1,9	10	32	QVHMMKA10240X1,90X10	35.20
102	40	2	10	32	QVHMMKA10240X2,00X10	35.20
102	40	2,5	10	32	QVHMMKA10240X2,50X10	45.40
102	40	3	10	32	QVHMMKA10240X3,00X10	52.50
102	40	3,5	10	32	QVHMMKA10240X3,50X10	58.70
102	40	4	10	32	QVHMMKA10240X4,00X10	64.90
102	40	5	10	32	QVHMMKA10240X5,00X10	78.20
102	40	6	10	32	QVHMMKA10240X6,00X10	92.30
102	50	0,3	13	48	QVHMMKA10250X0,30X13	24.60
102	50	0,35	13	48	QVHMMKA10250X0,35X13	24.60
102	50	0,4	13	48	QVHMMKA10250X0,40X13	24.60
102	50	0,5	13	48	QVHMMKA10250X0,50X13	25.50
102	50	0,6	13	48	QVHMMKA10250X0,60X13	25.50
102	50	0,7	13	40	QVHMMKA10250X0,70X13	26.70
102	50	0,8	13	40	QVHMMKA10250X0,80X13	28.90
102	50	0,9	13	40	QVHMMKA10250X0,90X13	29.80



Typ	D js15	E +/- 0,01	d H7	Z	Artikelcode	EUR
102	50	1	13	40	QVHMMKA10250X1,00X13	30.70
102	50	1,1	13	40	QVHMMKA10250X1,10X13	31.70
102	50	1,2	13	40	QVHMMKA10250X1,20X13	32.50
102	50	1,3	13	32	QVHMMKA10250X1,30X13	36.60
102	50	1,4	13	32	QVHMMKA10250X1,40X13	37.50
102	50	1,5	13	32	QVHMMKA10250X1,50X13	39.20
102	50	1,6	13	32	QVHMMKA10250X1,60X13	40.10
102	50	1,7	13	32	QVHMMKA10250X1,70X13	40.50
102	50	1,8	13	32	QVHMMKA10250X1,80X13	43.30
102	50	1,9	13	32	QVHMMKA10250X1,90X13	43.30
102	50	2	13	32	QVHMMKA10250X2,00X13	44.50
102	50	2,5	13	32	QVHMMKA10250X2,50X13	54.40
102	50	3	13	24	QVHMMKA10250X3,00X13	63.20
102	50	3,5	13	24	QVHMMKA10250X3,50X13	72.10
102	50	4	13	24	QVHMMKA10250X4,00X13	76.40
102	50	5	13	24	QVHMMKA10250X5,00X13	93.30
102	50	6	13	20	QVHMMKA10250X6,00X13	108.50
102	63	0,3	16	64	QVHMMKA10263X0,30X16	40.50
102	63	0,35	16	64	QVHMMKA10263X0,35X16	38.20

Typ	D js15	E +/- 0,01	d H7	Z	Artikelcode	EUR
102	63	0,4	16	64	QVHMMKA10263X0,40X16	34.70
102	63	0,5	16	64	QVHMMKA10263X0,50X16	33.90
102	63	0,6	16	48	QVHMMKA10263X0,60X16	34.70
102	63	0,7	16	48	QVHMMKA10263X0,70X16	39.20
102	63	0,8	16	48	QVHMMKA10263X0,80X16	43.30
102	63	0,9	16	48	QVHMMKA10263X0,90X16	43.60
102	63	1	16	48	QVHMMKA10263X1,00X16	44.50
102	63	1,1	16	40	QVHMMKA10263X1,10X16	46.20
102	63	1,2	16	40	QVHMMKA10263X1,20X16	48.10
102	63	1,3	16	40	QVHMMKA10263X1,30X16	49.00
102	63	1,4	16	40	QVHMMKA10263X1,40X16	49.80
102	63	1,5	16	40	QVHMMKA10263X1,50X16	50.80
102	63	1,6	16	40	QVHMMKA10263X1,60X16	53.40
102	63	1,7	16	40	QVHMMKA10263X1,70X16	56.00
102	63	1,8	16	40	QVHMMKA10263X1,80X16	56.90
102	63	1,9	16	40	QVHMMKA10263X1,90X16	59.60
102	63	2	16	40	QVHMMKA10263X2,00X16	61.30
102	63	2,5	16	32	QVHMMKA10263X2,50X16	73.90
102	63	3	16	32	QVHMMKA10263X3,00X16	83.60

Weiter Abmessungen auf Anfrage lieferbar.



VHM Kreissägen: Aufnahmen für Kreissägen

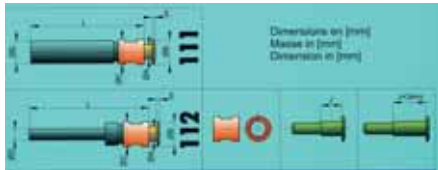

WGR

Typ	ø A	ø D	L	E	ø B; ø C	Mutter	Schraube	Artikelcode	EUR
111	5	10	60	3	10	P111015	P111025	P1115	172.00
111	10	16	73	3	17	P1110110	P1110210	P11110	172.00
112	5	7	50	3	10	P111015	P111025	P11257	172.00
112	8	7	51	3	15	P111018	P111028	P11287	172.00
112	8	10	61	3	15	P111018	P111028	P112810	172.00
112	10	7	53	3	17	P1110110	P1110210	P112107	172.00
112	10	10	63	3	17	P1110110	P1110210	P1121010	172.00
112	13	10	63	3	20	P1110113	P1110213	P11213	112.00
112	13	16	73	3	20	P1110113	P1110213	P1121316	172.00
112	16	16	76	3	24	P1110116	P1110216	P1121616	172.00



VHM Bohrungsfräser für Chirurgie: VHM Winkelstirnfräser 60Grad 2 Schnitte Kat. 228

Beschreibung:

Winkelstirnfräser 60 Grad aus VHM
2 Schnitte

Auf Wunsch mit Beschichtung lieferbar.

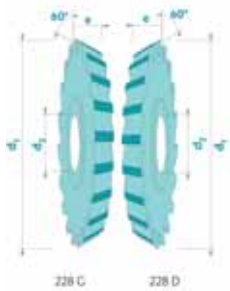

Typ	d1	e	d2	Z	Artikelcode	EUR
228	20	1	5	20	228Dd20e1.0 / 228Gd20e1.0	72.70
228	20	1,2	5	20	228Dd20e1.2 / 228Gd20e1.2	77.90
228	20	1,5	5	20	228Dd20e1.5 / 228Gd20e1.5	89.20
228	20	2	5	20	228Dd20e2.0 / 228Gd20e2.0	94.50
228	25	1	8	20	228Dd25e1.0 / 228Gd25e1.0	105.80
228	25	1,5	8	20	228Dd25e1.5 / 228Gd25e1.5	105.80
228	25	2	8	20	228Dd25e2.0 / 228Gd25e2.0	124.50
228	30	1	8	30	228Dd30e1.0 / 228Gd30e1.0	129.70
228	30	2	8	24	228Dd30e2.0 / 228Gd30e2.0	134.90
228	30	2,5	8	24	228Dd30e2.5 / 228Gd30e2.5	140.00
228	30	3	8	24	228Dd30e3.0 / 228Gd30e3.0	145.30
228	30	4	8	24	228Dd30e4.0 / 228Gd30e4.0	160.80
228	30	5	8	24	228Dd30e5.0 / 228Gd30e5.0	191.90
228	40	2	10	32	228Dd40e2.0 / 228Gd40e2.0	160.80
228	40	3	10	32	228Dd40e3.0 / 228Gd40e3.0	181.50
228	40	4	10	32	228Dd40e4.0 / 228Gd40e4.0	202.30
228	40	6	10	32	228Dd40e6.0 / 228Gd40e6.0	217.80
228	50	3	13	32	228Dd50e3.0 / 228Gd50e3.0	202.30
228	50	4	13	32	228Dd50e4.0 / 228Gd50e4.0	225.10
228	63	4	16	40	228Dd63e4.0 / 228Gd63e4.0	237.50
228	63	5	16	40	228Dd63e5.0 / 228Gd63e5.0	261.30

Bitte bei Bestellung Ausführung rechts "D" oder links "G" angeben.

Weitere Abmessungen auf Anfrage lieferbar.



VHM Bohrungsfräser für Chirurgie: VHM Winkelstirnfräser 45Grad 2 Schnitte Kat. 228-1

Beschreibung:

Winkelstirnfräser 45 Grad aus VHM
2 Schnitte

Auf Wunsch mit Beschichtung lieferbar.

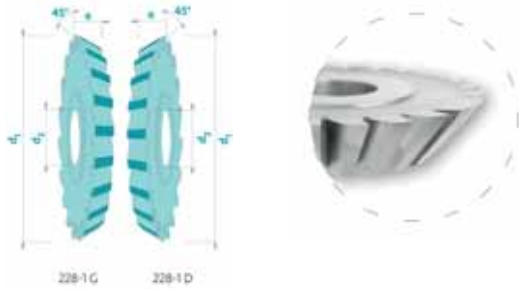

Typ	d1	e	d2	Z	Artikelcode	EUR
228-1	20	1	5	20	228-1Dd20e1.0 / 228-1Gd20e1.0	72.70
228-1	20	1,2	5	20	228-1Dd20e1.2 / 228-1Gd20e1.2	77.90
228-1	20	1,5	5	20	228-1Dd20e1.5 / 228-1Gd20e1.5	89.20
228-1	20	2	5	20	228-1Dd20e2.0 / 228-1Gd20e2.0	94.50
228-1	25	1	8	20	228-1Dd25e1.0 / 228-1Gd25e1.0	100.70
228-1	25	1,5	8	20	228-1Dd25e1.5 / 228-1Gd25e1.5	105.80
228-1	25	2	8	20	228-1Dd25e2.0 / 228-1Gd25e2.0	124.50
228-1	30	1	8	30	228-1Dd30e1.0 / 228-1Gd30e1.0	129.70
228-1	30	2	8	24	228-1Dd30e2.0 / 228-1Gd30e2.0	134.90
228-1	30	2,5	8	24	228-1Dd30e2.5 / 228-1Gd30e2.5	140.00
228-1	30	3	8	24	228-1Dd30e3.0 / 228-1Gd30e3.0	145.30
228-1	30	4	8	24	228-1Dd30e4.0 / 228-1Gd30e4.0	160.80
228-1	30	5	8	24	228-1Dd30e5.0 / 228-1Gd30e5.0	191.90
228-1	40	2	10	32	228-1Dd40e2.0 / 228-1Gd40e2.0	160.80
228-1	40	3	10	32	228-1Dd40e3.0 / 228-1Gd40e3.0	181.50
228-1	40	4	10	32	228-1Dd40e4.0 / 228-1Gd40e4.0	202.30
228-1	40	6	10	32	228-1Dd40e6.0 / 228-1Gd40e6.0	217.80
228-1	50	3	13	32	228-1Dd50e3.0 / 228-1Gd50e3.0	202.30
228-1	50	4	13	32	228-1Dd50e4.0 / 228-1Gd50e4.0	225.10
228-1	63	4	16	40	228-1Dd63e4.0 / 228-1Gd63e4.0	237.50
228-1	63	5	16	40	228-1Dd63e5.0 / 228-1Gd63e5.0	261.30

Bitte bei Bestellung Ausführung rechts "D" oder links "G" angeben.

Weitere Abmessungen auf Anfrage lieferbar.



VHM Bohrungsfräser für Chirurgie: VHM Winkelstirnfräser 30Grad 1 Schnitt Kat. 228-3

Beschreibung:

Winkelstirnfräser 30 Grad aus VHM
1 Schnitt

Auf Wunsch mit Beschichtung lieferbar.

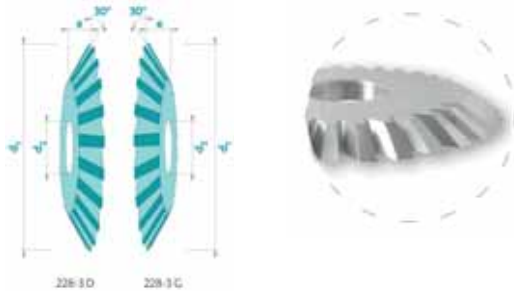

Typ	d1	e	d2	Z	Artikelcode	EUR
228-3	20	2	5	20	228-3Dd20e2.0 / 228-3Gd20e2.0	82.00
228-3	20	2,5	5	20	228-3Dd20e2.5 / 228-3Gd20e2.5	88.20
228-3	20	3	5	20	228-3Dd20e3.0 / 228-3Gd20e3.0	98.60
228-3	30	2	8	30	228-3Dd30e2.0 / 228-3Gd30e2.0	119.30
228-3	30	2,5	8	30	228-3Dd30e2.5 / 228-3Gd30e2.5	129.70
228-3	30	3	8	30	228-3Dd30e3.0 / 228-3Gd30e3.0	140.00
228-3	40	2	10	40	228-3Dd40e2.0 / 228-3Gd40e2.0	143.20
228-3	40	2,5	10	40	228-3Dd40e2.5 / 228-3Gd40e2.5	153.60
228-3	40	3	10	40	228-3Dd40e3.0 / 228-3Gd40e3.0	163.90
228-3	50	2	13	50	228-3Dd50e2.0 / 228-3Gd50e2.0	166.00
228-3	50	2,5	13	50	228-3Dd50e2.5 / 228-3Gd50e2.5	186.70
228-3	50	3	13	50	228-3Dd50e3.0 / 228-3Gd50e3.0	202.30

Bitte bei Bestellung Ausführung rechts "D" oder links "G" angeben.

Weitere Abmessungen auf Anfrage lieferbar.



VHM Bohrungsfräser für Chirurgie: VHM Winkelstirnfräser 45Grad 1 Schnitt Kat. 228-4

Beschreibung:

Winkelstirnfräser 45 Grad aus VHM
1 Schnitt

Auf Wunsch mit Beschichtung lieferbar.

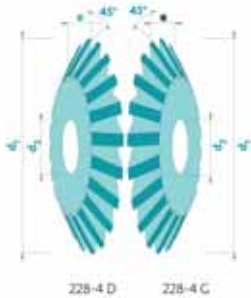

Typ	d1	e	d2	Z	Artikelcode	EUR
228-4	20	2	5	20-30	228-4Dd20e2.0Z## / 228-4Gd20e2.0Z##	74.70
228-4	20	2,5	5	20-30	228-4Dd20e2.5Z## / 228-4Gd20e2.5Z##	81.00
228-4	20	3	5	20-30	228-4Dd20e3.0Z## / 228-4Gd20e3.0Z##	88.20
228-4	30	2	8	30-40	228-4Dd30e2.0Z## / 228-4Gd30e2.0Z##	119.30
228-4	30	2,5	8	30-40	228-4Dd30e2.5Z## / 228-4Gd30e2.5Z##	129.70
228-4	30	3	8	30-40	228-4Dd30e3.0Z## / 228-4Gd30e3.0Z##	140.00
228-4	30	4	8	30-40	228-4Dd30e4.0Z## / 228-4Gd30e4.0Z##	160.80
228-4	30	5	8	30-40	228-4Dd30e5.0Z## / 228-4Gd30e5.0Z##	176.40
228-4	30	6	8	30-40	228-4Dd30e6.0Z## / 228-4Gd30e6.0Z##	197.10
228-4	40	2	10	40-50	228-4Dd40e2.0Z## / 228-4Gd40e2.0Z##	150.40
228-4	40	3	10	40-50	228-4Dd40e3.0Z## / 228-4Gd40e3.0Z##	166.00
228-4	40	4	10	40-50	228-4Dd40e4.0Z## / 228-4Gd40e4.0Z##	181.50
228-4	40	5	10	40-50	228-4Dd40e5.0Z## / 228-4Gd40e5.0Z##	191.90
228-4	40	6	10	30-40	228-4Dd40e6.0Z## / 228-4Gd40e6.0Z##	212.70

Bitte bei Bestellung Ausführung rechts "D" oder links "G" und Zähnezahl angeben.

Weitere Abmessungen auf Anfrage lieferbar.



VHM Bohrungsfräser für Chirurgie: VHM Winkelstirnfräser 60Grad 1 Schnitt Kat. 228-5

Beschreibung:

Winkelstirnfräser 60 Grad aus VHM
1 Schnitt

Auf Wunsch mit Beschichtung lieferbar.

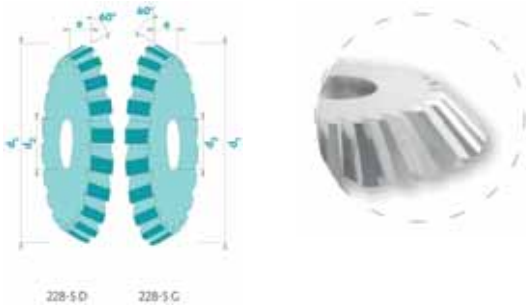

Typ	d1	e	d2	Z	Artikelcode	EUR
228-5	20	2	5	20-30	228-5Dd20e2.0Z## / 228-5Gd20e2.0Z##	74.70
228-5	20	2,5	5	20-30	228-5Dd20e2.5Z## / 228-5Gd20e2.5Z##	81.00
228-5	20	3	5	20-30	228-5Dd20e3.0Z## / 228-5Gd20e3.0Z##	88.20
228-5	30	2	8	30-40	228-5Dd30e2.0Z## / 228-5Gd30e2.0Z##	119.30
228-5	30	2,5	8	30-40	228-5Dd30e2.5Z## / 228-5Gd30e2.5Z##	129.70
228-5	30	3	8	30-40	228-5Dd30e3.0Z## / 228-5Gd30e3.0Z##	140.00
228-5	30	4	8	30-40	228-5Dd30e4.0Z## / 228-5Gd30e4.0Z##	160.80
228-5	30	5	8	30-40	228-5Dd30e5.0Z## / 228-5Gd30e5.0Z##	176.40
228-5	30	6	8	30-40	228-5Dd30e6.0Z## / 228-5Gd30e6.0Z##	197.10
228-5	40	2	10	40-50	228-5Dd40e2.0Z## / 228-5Gd40e2.0Z##	150.40
228-5	40	3	10	40-50	228-5Dd40e3.0Z## / 228-5Gd40e3.0Z##	166.00
228-5	40	4	10	40-50	228-5Dd40e4.0Z## / 228-5Gd40e4.0Z##	181.50
228-5	40	5	10	40-50	228-5Dd40e5.0Z## / 228-5Gd40e5.0Z##	191.90
228-5	40	6	10	30-40	228-5Dd40e6.0Z## / 228-5Gd40e6.0Z##	212.70

Bitte bei Bestellung Ausführung rechts "D" oder links "G" und Zähnezahl angeben.

Weitere Abmessungen auf Anfrage lieferbar.



VHM Bohrungsfräser für Chirurgie: VHM Prismenfräser 60Grad Kat. 229-1

Beschreibung:

Prismenfräser 60 Grad aus VHM

Auf Wunsch mit Beschichtung lieferbar.

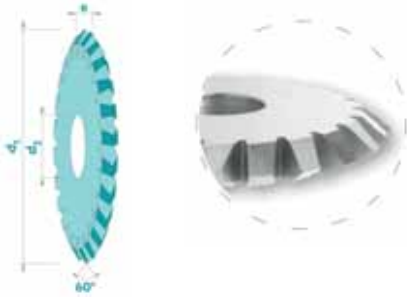

Typ	d1	e	d2	Z	Artikelcode	EUR
229-1	20	0,5	5	20	QBELET229120X0,5X5Z20	83.00
229-1	20	1	5	20	QBELET229120X1X5Z20	88.20
229-1	20	1,5	5	20	QBELET229120X1,5X5Z20	98.60
229-1	20	2	5	20	QBELET229120X2X5Z20	105.80
229-1	25	1	8	20	QBELET229125X1X8Z20	104.80
229-1	25	1,5	8	20	QBELET229125X1,5X8Z20	112.00
229-1	25	2	8	20	QBELET229125X2X8Z20	117.30
229-1	30	2	8	24	QBELET229130X2X8Z24	123.50
229-1	30	2,5	8	24	QBELET229130X2,5X8Z24	128.60
229-1	30	3	8	24	QBELET229130X3X8Z24	135.90
229-1	30	4	8	24	QBELET229130X4X8Z24	168.10
229-1	30	5	8	24	QBELET229130X5X8Z24	191.90
229-1	40	2	10	32	QBELET229140X2X10Z32	134.90
229-1	40	3	10	32	QBELET229140X3X10Z32	146.30
229-1	40	4	10	32	QBELET229140X4X10Z32	174.30
229-1	40	5	10	32	QBELET229140X5X10Z32	202.30

Typ	d1	e	d2	Z	Artikelcode	EUR
229-1	50	2	13	32	QBELET229150X2X13Z32	168.10
229-1	50	3	13	32	QBELET229150X3X13Z32	190.90
229-1	50	4	13	32	QBELET229150X4X13Z32	213.70
229-1	50	5	13	32	QBELET229150X5X13Z32	237.50
229-1	50	6	13	32	QBELET229150X6X13Z32	274.80
229-1	63	2	16	40	QBELET229163X2X16Z40	212.70
229-1	63	3	16	40	QBELET229163X3X16Z40	236.40
229-1	63	4	16	40	QBELET229163X4X16Z40	260.30
229-1	63	5	16	40	QBELET229163X5X16Z40	272.80
229-1	63	6	16	40	QBELET229163X6X16Z40	326.60
229-1	80	2	22	48	QBELET229180X2X22Z48	291.40
229-1	80	3	22	48	QBELET229180X3X22Z48	304.90
229-1	80	4	22	48	QBELET229180X4X22Z48	329.80
229-1	80	5	22	48	QBELET229180X5X22Z48	364.00
229-1	80	6	22	48	QBELET229180X6X22Z48	435.50

Weitere Abmessungen auf Anfrage lieferbar.



VHM Bohrungsfräser für Chirurgie: VHM Prismenfräser 90Grad Kat. 229-2

Beschreibung:

Prismenfräser 90 Grad aus VHM

Auf Wunsch mit Beschichtung lieferbar.

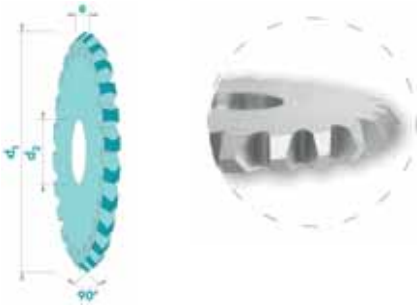

Typ	d1	e	d2	Z	Artikelcode	EUR
229-2	20	0,5	5	20	QBELET229220X0,5X5Z20	72.70
229-2	20	1	5	20	QBELET229220X1X5Z20	83.00
229-2	20	1,5	5	20	QBELET229220X1,5X5Z20	87.20
229-2	20	2	5	20	QBELET229220X2X5Z20	95.50
229-2	25	1	8	20	QBELET229225X1X8Z20	87.20
229-2	25	1,5	8	20	QBELET229225X1,5X8Z20	95.50
229-2	25	2	8	20	QBELET229225X2X8Z20	100.70
229-2	30	2	8	24	QBELET229230X2X8Z24	106.90
229-2	30	2,5	8	24	QBELET229230X2,5X8Z24	113.10
229-2	30	3	8	24	QBELET229230X3X8Z24	129.70
229-2	30	4	8	24	QBELET229230X4X8Z24	153.60
229-2	30	5	8	24	QBELET229230X5X8Z24	174.30
229-2	40	2	10	32	QBELET229240X2X10Z32	118.20
229-2	40	3	10	32	QBELET229240X3X10Z32	141.10
229-2	40	4	10	32	QBELET229240X4X10Z32	174.30
229-2	40	5	10	32	QBELET229240X5X10Z32	195.00

Typ	d1	e	d2	Z	Artikelcode	EUR
229-2	50	2	13	32	QBELET229250X2X13Z32	162.80
229-2	50	3	13	32	QBELET229250X3X13Z32	192.20
229-2	50	4	13	32	QBELET229250X4X13Z32	198.20
229-2	50	5	13	32	QBELET229250X5X13Z32	221.90
229-2	50	6	13	32	QBELET229250X6X13Z32	254.10
229-2	63	2	16	40	QBELET229263X2X16Z40	212.70
229-2	63	3	16	40	QBELET229263X3X16Z40	226.10
229-2	63	4	16	40	QBELET229263X4X16Z40	238.50
229-2	63	5	16	40	QBELET229263X5X16Z40	256.20
229-2	63	6	16	40	QBELET229263X6X16Z40	305.90
229-2	80	2	22	48	QBELET229280X2X22Z48	280.00
229-2	80	3	22	48	QBELET229280X3X22Z48	294.60
229-2	80	4	22	48	QBELET229280X4X22Z48	308.00
229-2	80	5	22	48	QBELET229280X5X22Z48	343.30
229-2	80	6	22	48	QBELET229280X6X22Z48	414.80

Weitere Abmessungen auf Anfrage lieferbar.



VHM Bohrungsfräser für Chirurgie: VHM Prismenfräser 120Grad Kat. 229-3

Beschreibung:

Prismenfräser 120 Grad aus VHM

Auf Wunsch mit Beschichtung lieferbar.

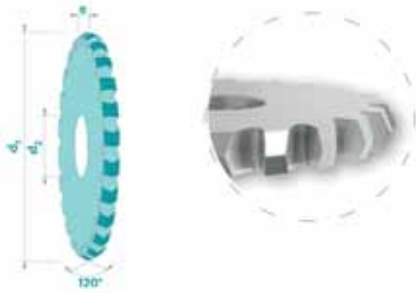

Typ	d1	e	d2	Z	Artikelcode	EUR
229-3	20	0,5	5	20	QBELET229320X0,5X5Z20	72.70
229-3	20	1	5	20	QBELET229320X1X5Z20	83.00
229-3	20	1,5	5	20	QBELET229320X1,5X5Z20	87.20
229-3	20	2	5	20	QBELET229320X2X5Z20	95.50
229-3	25	1	8	20	QBELET229325X1X8Z20	87.20
229-3	25	1,5	8	20	QBELET229325X1,5X8Z20	95.50
229-3	25	2	8	20	QBELET229325X2X8Z20	100.70
229-3	30	2	8	24	QBELET229330X2X8Z24	106.90
229-3	30	2,5	8	24	QBELET229330X2,5X8Z24	113.10
229-3	30	3	8	24	QBELET229330X3X8Z24	129.70
229-3	30	4	8	24	QBELET229330X4X8Z24	153.60
229-3	30	5	8	24	QBELET229330X5X8Z24	174.30
229-3	40	2	10	32	QBELET229340X2X10Z32	118.20
229-3	40	3	10	32	QBELET229340X3X10Z32	141.10
229-3	40	4	10	32	QBELET229340X4X10Z32	174.30
229-3	40	5	10	32	QBELET229340X5X10Z32	195.00

Typ	d1	e	d2	Z	Artikelcode	EUR
229-3	50	2	13	32	QBELET229350X2X13Z32	162.80
229-3	50	3	13	32	QBELET229350X3X13Z32	174.30
229-3	50	4	13	32	QBELET229350X4X13Z32	198.20
229-3	50	5	13	32	QBELET229350X5X13Z32	221.90
229-3	50	6	13	32	QBELET229350X6X13Z32	254.10
229-3	63	2	16	40	QBELET229363X2X16Z40	212.70
229-3	63	3	16	40	QBELET229363X3X16Z40	226.10
229-3	63	4	16	40	QBELET229363X4X16Z40	238.50
229-3	63	5	16	40	QBELET229363X5X16Z40	256.20
229-3	63	6	16	40	QBELET229363X6X16Z40	305.90
229-3	80	2	22	48	QBELET229380X2X22Z48	300.80
229-3	80	3	22	48	QBELET229380X3X22Z48	326.60
229-3	80	4	22	48	QBELET229380X4X22Z48	347.40
229-3	80	5	22	48	QBELET229380X5X22Z48	399.20
229-3	80	6	22	48	QBELET229380X6X22Z48	440.70

Weitere Abmessungen auf Anfrage lieferbar.



VHM Bohrungsfräser für Chirurgie: VHM Radiusfräser konvex Kat. 232

Beschreibung:

Radiusfräser konvex aus VHM

Auf Wunsch mit Beschichtung lieferbar.

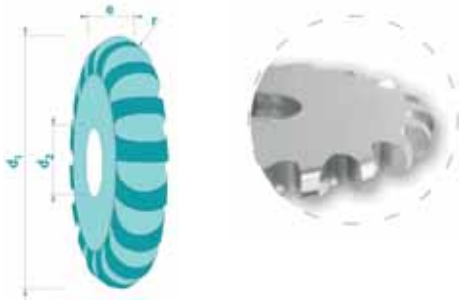

Typ	d1	e	d2	r	Z	Artikelcode	EUR
232	10	0,2	3	0,1	15	QBELET23210X0,2X3Z15	67.50
232	10	0,5	3	0,25	15	QBELET23210X0,5X3Z15	72.70
232	10	1	3	0,5	15	QBELET23210X1X3Z15	77.90
232	10	1,5	3	0,75	15	QBELET23210X1,5X3Z15	88.20
232	10	2	3	1	8	QBELET23210X2X3Z8	98.60
232	10	3	3	1,5	8	QBELET23210X3X3Z8	119.30
232	10	4	3	2	8	QBELET23210X4X3Z8	140.00
232	15	0,2	5	0,1	20	QBELET23215X0,2X5Z20	77.90
232	15	0,5	5	0,25	20	QBELET23215X0,5X5Z20	83.00
232	15	1	5	0,5	20	QBELET23215X1X5Z20	88.20
232	15	1,5	5	0,75	12	QBELET23215X1,5X5Z12	98.60
232	15	2	5	1	12	QBELET23215X2X5Z12	109.00
232	15	3	5	1,5	10	QBELET23215X3X5Z10	140.00
232	15	3,5	5	1,75	10	QBELET23215X3,5X5Z10	150.40
232	15	4	5	2	10	QBELET23215X4X5Z10	166.00
232	15	5	5	2,5	10	QBELET23215X5X5Z10	197.10
232	20	0,2	5	0,1	20	QBELET23220X0,2X5Z20	77.90
232	20	0,3	5	0,15	20	QBELET23220X0,3X5Z20	83.00
232	20	0,4	5	0,2	20	QBELET23220X0,4X5Z20	83.00
232	20	0,5	5	0,25	18	QBELET23220X0,5X5Z18	88.20
232	20	0,6	5	0,3	18	QBELET23220X0,6X5Z18	98.60
232	20	0,7	5	0,35	18	QBELET23220X0,7X5Z18	114.10
232	20	0,8	5	0,4	18	QBELET23220X0,8X5Z18	134.90
232	20	0,9	5	0,45	18	QBELET23220X0,9X5Z18	155.60
232	20	1	5	0,5	20	QBELET23220X1X5Z20	98.60
232	20	1,1	5	0,55	20	QBELET23220X1,1X5Z20	124.50
232	20	1,2	5	0,6	16	QBELET23220X1,2X5Z16	124.50

Typ	d1	e	d2	r	Z	Artikelcode	EUR
232	20	1,3	5	0,65	16	QBELET23220X1,3X5Z16	124.50
232	20	1,4	5	0,7	16	QBELET23220X1,4X5Z16	124.50
232	20	1,5	5	0,75	16	QBELET23220X1,5X5Z16	114.10
232	20	1,6	5	0,8	16	QBELET23220X1,6X5Z16	140.00
232	20	1,7	5	0,85	16	QBELET23220X1,7X5Z16	140.00
232	20	1,8	5	0,9	16	QBELET23220X1,8X5Z16	140.00
232	20	1,9	5	0,95	16	QBELET23220X1,9X5Z16	140.00
232	20	2	5	1	16	QBELET23220X2X5Z16	129.70
232	20	2,1	5	1,05	16	QBELET23220X2,1X5Z16	145.30
232	20	2,2	5	1,1	16	QBELET23220X2,2X5Z16	145.30
232	20	2,3	5	1,15	16	QBELET23220X2,3X5Z16	145.30
232	20	2,4	5	1,2	16	QBELET23220X2,4X5Z16	145.30
232	20	2,5	5	1,25	16	QBELET23220X2,5X5Z16	145.30
232	20	2,6	5	1,3	16	QBELET23220X2,6X5Z16	171.10
232	20	2,7	5	1,35	16	QBELET23220X2,7X5Z16	171.10
232	20	2,8	5	1,4	16	QBELET23220X2,8X5Z16	171.10
232	20	2,9	5	1,45	16	QBELET23220X2,9X5Z16	171.10
232	20	3	5	1,5	16	QBELET23220X3X5Z16	155.60
232	20	3,5	5	1,75	16	QBELET23220X3,5X5Z16	191.90
232	20	4	5	2	16	QBELET23220X4X5Z16	181.50
232	20	4,5	5	2,25	16	QBELET23220X4,5X5Z16	217.80
232	20	5	5	2,5	12	QBELET23220X5X5Z12	207.40
232	20	6	5	3	12	QBELET23220X6X5Z12	238.50
232	25	0,2	8	0,1	30	QBELET23225X0,2X8Z30	88.20
232	25	0,3	8	0,15	30	QBELET23225X0,3X8Z30	91.30
232	25	0,4	8	0,2	30	QBELET23225X0,4X8Z30	91.30
232	25	0,5	8	0,25	20	QBELET23225X0,5X8Z20	93.40



Typ	d1	e	d2	r	Z	Artikelcode	EUR
232	25	0,6	8	0,3	20	QBELET23225X0,6X8Z20	119.30
232	25	0,7	8	0,35	20	QBELET23225X0,7X8Z20	119.30
232	25	0,8	8	0,4	20	QBELET23225X0,8X8Z20	119.30
232	25	0,9	8	0,45	20	QBELET23225X0,9X8Z20	119.30
232	25	1	8	0,5	20	QBELET23225X1,0X8Z20	109.00
232	25	1,1	8	0,55	20	QBELET23225X1,1X8Z20	140.00
232	25	1,2	8	0,6	20	QBELET23225X1,2X8Z20	140.00
232	25	1,3	8	0,65	20	QBELET23225X1,3X8Z20	140.00
232	25	1,4	8	0,7	20	QBELET23225X1,4X8Z20	140.00
232	25	1,5	8	0,75	16	QBELET23225X1,5X8Z16	129.70
232	25	1,6	8	0,8	16	QBELET23225X1,6X8Z16	150.40
232	25	1,7	8	0,85	16	QBELET23225X1,7X8Z16	150.40
232	25	1,8	8	0,9	16	QBELET23225X1,8X8Z16	150.40
232	25	1,9	8	0,95	16	QBELET23225X1,9X8Z16	150.40
232	25	2	8	1	20	QBELET23225X2,0X8Z20	145.30
232	25	2,1	8	1,05	20	QBELET23225X2,1X8Z20	181.50
232	25	2,2	8	1,1	20	QBELET23225X2,2X8Z20	181.50
232	25	2,3	8	1,15	20	QBELET23225X2,3X8Z20	181.50
232	25	2,4	8	1,2	20	QBELET23225X2,4X8Z20	181.50
232	25	2,5	8	1,25	20	QBELET23225X2,5X8Z20	181.50
232	25	2,6	8	1,3	20	QBELET23225X2,6X8Z20	181.50
232	25	2,7	8	1,35	20	QBELET23225X2,7X8Z20	181.50
232	25	2,8	8	1,4	20	QBELET23225X2,8X8Z20	181.50
232	25	2,9	8	1,45	20	QBELET23225X2,9X8Z20	181.50
232	25	3	8	1,5	16	QBELET23225X3,0X8Z16	171.10
232	25	3,5	8	1,75	16	QBELET23225X3,5X8Z16	202.30
232	25	4	8	2	16	QBELET23225X4,0X8Z16	202.30
232	25	4,5	8	2,25	16	QBELET23225X4,5X8Z16	243.70
232	25	5	8	2,5	16	QBELET23225X5,0X8Z16	233.40
232	25	6	8	3	16	QBELET23225X6,0X8Z16	264.50
232	30	0,2	8	0,1	30	QBELET23230X0,2X8Z30	93.40
232	30	0,5	8	0,25	24	QBELET23230X0,5X8Z24	98.60
232	30	1	8	0,5	24	QBELET23230X1,0X8Z24	114.10
232	30	1,1	8	0,55	20	QBELET23230X1,1X8Z20	140.00
232	30	1,2	8	0,6	20	QBELET23230X1,2X8Z20	140.00
232	30	1,3	8	0,65	20	QBELET23230X1,3X8Z20	140.00
232	30	1,4	8	0,7	20	QBELET23230X1,4X8Z20	140.00
232	30	1,5	8	0,75	20	QBELET23230X1,5X8Z20	134.90
232	30	1,6	8	0,8	20	QBELET23230X1,6X8Z20	160.80
232	30	1,7	8	0,85	20	QBELET23230X1,7X8Z20	160.80
232	30	1,8	8	0,9	20	QBELET23230X1,8X8Z20	160.80
232	30	1,9	8	0,95	20	QBELET23230X1,9X8Z20	160.80

Typ	d1	e	d2	r	Z	Artikelcode	EUR
232	30	2	8	1	20	QBELET23230X2,0X8Z20	150.40
232	30	2,1	8	1,05	20	QBELET23230X2,1X8Z20	217.80
232	30	2,2	8	1,1	20	QBELET23230X2,2X8Z20	217.80
232	30	2,3	8	1,15	20	QBELET23230X2,3X8Z20	217.80
232	30	2,4	8	1,2	20	QBELET23230X2,4X8Z20	217.80
232	30	2,5	8	1,25	20	QBELET23230X2,5X8Z20	217.80
232	30	2,6	8	1,3	20	QBELET23230X2,6X8Z20	217.80
232	30	2,7	8	1,35	20	QBELET23230X2,7X8Z20	217.80
232	30	2,8	8	1,4	20	QBELET23230X2,8X8Z20	217.80
232	30	2,9	8	1,45	20	QBELET23230X2,9X8Z20	217.80
232	30	3	8	1,5	15	QBELET23230X3,0X8Z15	197.10
232	30	3,5	8	1,75	15	QBELET23230X3,5X8Z15	217.80
232	30	4	8	2	15	QBELET23230X4,0X8Z15	212.70
232	30	4,5	8	2,25	15	QBELET23230X4,5X8Z15	259.20
232	30	5	8	2,5	15	QBELET23230X5,0X8Z15	259.20
232	30	6	8	3	15	QBELET23230X6,0X8Z15	280.00
232	30	6,1	8	3,05	15	QBELET23230X6,1X8Z15	326.60
232	40	0,2	10	0,1	40	QBELET23240X0,2X10Z40	114.10
232	40	0,5	10	0,25	40	QBELET23240X0,5X10Z40	119.30
232	40	0,6	10	0,3	40	QBELET23240X0,6X10Z40	150.40
232	40	0,7	10	0,35	40	QBELET23240X0,7X10Z40	150.40
232	40	0,8	10	0,4	40	QBELET23240X0,8X10Z40	150.40
232	40	0,9	10	0,45	40	QBELET23240X0,9X10Z40	150.40
232	40	1	10	0,5	28	QBELET23240X1,0X10Z28	129.70
232	40	1,1	10	0,55	24	QBELET23240X1,1X10Z24	171.10
232	40	1,2	10	0,6	24	QBELET23240X1,2X10Z24	171.10
232	40	1,3	10	0,65	24	QBELET23240X1,3X10Z24	171.10
232	40	1,4	10	0,7	24	QBELET23240X1,4X10Z24	171.10
232	40	1,5	10	0,75	24	QBELET23240X1,5X10Z24	155.60
232	40	1,6	10	0,8	24	QBELET23240X1,6X10Z24	171.10
232	40	1,7	10	0,85	24	QBELET23240X1,7X10Z24	171.10
232	40	1,8	10	0,9	24	QBELET23240X1,8X10Z24	171.10
232	40	1,9	10	0,95	24	QBELET23240X1,9X10Z24	171.10
232	40	2	10	1	24	QBELET23240X2,0X10Z24	166.00
232	40	2,1	10	1,05	24	QBELET23240X2,1X10Z24	223.00
232	40	2,2	10	1,1	24	QBELET23240X2,2X10Z24	223.00
232	40	2,3	10	1,15	24	QBELET23240X2,3X10Z24	223.00
232	40	2,4	10	1,2	24	QBELET23240X2,4X10Z24	223.00
232	40	2,5	10	1,25	24	QBELET23240X2,5X10Z24	223.00
232	40	2,6	10	1,3	24	QBELET23240X2,6X10Z24	223.00
232	40	2,7	10	1,35	24	QBELET23240X2,7X10Z24	223.00
232	40	2,8	10	1,4	24	QBELET23240X2,8X10Z24	223.00

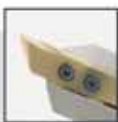

Typ	d1	e	d2	r	Z	Artikelcode	EUR
232	40	2,9	10	1,45	24	QBELET23240X2,9X10Z24	223.00
232	40	3	10	1,5	24	QBELET23240X3X10Z24	202.30
232	40	3,5	10	1,75	24	QBELET23240X3,5X10Z24	243.70
232	40	4	10	2	24	QBELET23240X4X10Z24	238.50
232	40	4,5	10	2,25	24	QBELET23240X4,5X10Z24	274.80
232	40	5	10	2,5	24	QBELET23240X5X10Z24	285.20
232	40	6	10	3	24	QBELET23240X6X10Z24	331.90
232	50	0,2	13	0,1	50	QBELET23250X0,2X13Z50	129.70
232	50	0,5	13	0,25	50	QBELET23250X0,5X13Z50	129.70
232	50	0,6	13	0,3	50	QBELET23250X0,6X13Z50	155.60
232	50	0,7	13	0,35	50	QBELET23250X0,7X13Z50	155.60
232	50	0,8	13	0,4	50	QBELET23250X0,8X13Z50	155.60
232	50	0,9	13	0,45	50	QBELET23250X0,9X13Z50	155.60
232	50	1	13	0,5	50	QBELET23250X1X13Z50	145.30
232	50	1,1	13	0,55	40	QBELET23250X1,1X13Z40	181.50
232	50	1,2	13	0,6	40	QBELET23250X1,2X13Z40	181.50
232	50	1,3	13	0,65	40	QBELET23250X1,3X13Z40	181.50
232	50	1,4	13	0,7	40	QBELET23250X1,4X13Z40	181.50
232	50	1,5	13	0,75	40	QBELET23250X1,5X13Z40	171.10
232	50	1,6	13	0,8	40	QBELET23250X1,6X13Z40	202.30
232	50	1,7	13	0,85	40	QBELET23250X1,7X13Z40	202.30
232	50	1,8	13	0,9	40	QBELET23250X1,8X13Z40	202.30
232	50	1,9	13	0,95	40	QBELET23250X1,9X13Z40	202.30
232	50	2	13	1	40	QBELET23250X2X13Z40	197.10
232	50	2,1	13	1,05	40	QBELET23250X2,1X13Z40	259.20
232	50	2,2	13	1,1	40	QBELET23250X2,2X13Z40	259.20
232	50	2,3	13	1,15	40	QBELET23250X2,3X13Z40	259.20
232	50	2,4	13	1,2	40	QBELET23250X2,4X13Z40	259.20
232	50	2,5	13	1,25	40	QBELET23250X2,5X13Z40	259.20
232	50	2,6	13	1,3	40	QBELET23250X2,6X13Z40	259.20
232	50	2,7	13	1,35	40	QBELET23250X2,7X13Z40	259.20
232	50	2,8	13	1,4	40	QBELET23250X2,8X13Z40	259.20
232	50	2,9	13	1,45	40	QBELET23250X2,9X13Z40	259.20
232	50	3	13	1,5	30	QBELET23250X3X13Z30	248.90
232	50	3,5	13	1,75	30	QBELET23250X3,5X13Z30	305.90
232	50	4	13	2	30	QBELET23250X4X13Z30	316.30

Typ	d1	e	d2	r	Z	Artikelcode	EUR
232	50	4,5	13	2,25	30	QBELET23250X4,5X13Z30	337.10
232	50	5	13	2,5	30	QBELET23250X5X13Z30	347.40
232	50	6	13	3	30	QBELET23250X6X13Z30	409.60
232	63	0,5	16	0,25	60	QBELET23263X0,5X16Z60	155.60
232	63	1	16	0,5	60	QBELET23263X1X16Z60	176.40
232	63	1,5	16	0,75	40	QBELET23263X1,5X16Z40	197.10
232	63	2	16	1	40	QBELET23263X2X16Z40	217.80
232	63	2,5	16	1,25	40	QBELET23263X2,5X16Z40	269.70
232	63	3	16	1,5	40	QBELET23263X3X16Z40	269.70
232	63	3,5	16	1,75	40	QBELET23263X3,5X16Z40	321.50
232	63	4	16	2	30	QBELET23263X4X16Z30	337.10
232	63	4,5	16	2,25	30	QBELET23263X4,5X16Z30	388.90
232	63	5	16	2,5	30	QBELET23263X5X16Z30	394.10
232	63	6	16	3	30	QBELET23263X6X16Z30	456.30
232	80	0,5	22	0,25	80	QBELET23280X0,5X22Z80	202.30
232	80	1	22	0,5	80	QBELET23280X1X22Z80	217.80
232	80	1,5	22	0,75	60	QBELET23280X1,5X22Z60	259.20
232	80	2	22	1	60	QBELET23280X2X22Z60	290.40
232	80	2,5	22	1,25	60	QBELET23280X2,5X22Z60	352.60
232	80	3	22	1,5	40	QBELET23280X3X22Z40	357.80
232	80	3,5	22	1,75	40	QBELET23280X3,5X22Z40	378.50
232	80	4	22	2	40	QBELET23280X4X22Z40	383.70
232	80	4,5	22	2,25	40	QBELET23280X4,5X22Z40	430.30
232	80	5	22	2,5	40	QBELET23280X5X22Z40	435.50
232	80	6	22	3	40	QBELET23280X6X22Z40	513.30
232	100	0,5	22	0,25	80	QBELET232100X0,5X22Z80	274.80
232	100	1	22	0,5	80	QBELET232100X1X22Z80	269.70
232	100	1,5	22	0,75	80	QBELET232100X1,5X22Z80	300.80
232	100	2	22	1	60	QBELET232100X2X22Z60	331.90
232	100	3	22	1,5	60	QBELET232100X3X22Z60	435.50
232	100	3,5	22	1,75	60	QBELET232100X3,5X22Z60	497.70
232	100	4	22	2	50	QBELET232100X4X22Z50	508.10
232	100	4,5	22	2,25	50	QBELET232100X4,5X22Z50	575.50
232	100	5	22	2,5	50	QBELET232100X5X22Z50	580.70
232	100	6	22	3	50	QBELET232100X6X22Z50	648.10

Weitere Abmessungen auf Anfrage lieferbar.



VHM Bohrungsfräser für Chirurgie: VHM Radiusfräser konkav Kat. 234

Beschreibung:

Radiusfräser konkav aus VHM



Auf Wunsch mit Beschichtung lieferbar.

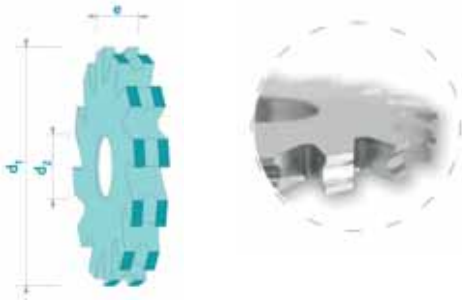

Typ	d1	e	d2	r	Z	Artikelcode	EUR
234	20	1.0	5	0.10 - 0.20	12 - 14	234d20e1.0r#.#Z##	150.40
234	20	1.5	5	0.30 - 0.40	12 - 14	234d20e1.5r#.#Z##	166.00
234	20	2.0	5	0.50 - 0.60	12 - 14	234d20e2.0r#.#Z##	181.50
234	20	3.0	5	0.70 - 1.00	10 - 12	234d20e3.0r#.#Z##	207.40
234	20	4.0	5	1.10 - 1.50	10 - 12	234d20e4.0r#.#Z##	241.70
234	20	5.0	5	1.60 - 1.80	10 - 12	234d20e5.0r#.#Z##	274.80
234	20	6.0	5	1.90 - 2.30	8 - 10	234d20e6.0r#.#Z##	311.10
234	25	1.0	8	0.10 - 0.20	15 - 16	234d25e1.0r#.#Z##	160.80
234	25	1.5	8	0.30 - 0.40	15 - 16	234d25e1.5r#.#Z##	181.50
234	25	2.0	8	0.50 - 0.60	14 - 16	234d25e2.0r#.#Z##	202.30
234	25	3.0	8	0.70 - 1.00	14 - 16	234d25e3.0r#.#Z##	233.40
234	25	4.0	8	1.10 - 1.50	12 - 14	234d25e4.0r#.#Z##	264.50
234	25	5.0	8	1.60 - 1.80	12 - 14	234d25e5.0r#.#Z##	300.80
234	25	6.0	8	1.90 - 2.30	12 - 14	234d25e6.0r#.#Z##	342.20
234	25	7.0	8	2.40 - 2.80	12 - 14	234d25e7.0r#.#Z##	383.70
234	25	8.0	8	2.90 - 3.30	10 - 12	234d25e8.0r#.#Z##	399.20
234	25	9.0	8	3.40 - 3.50	10 - 12	234d25e9.0r#.#Z##	425.20
234	30	1.0	8	0.10 - 0.30	16 - 18	234d30e1.0r#.#Z##	166.00
234	30	1.5	8	0.30 - 0.40	16 - 18	234d30e1.5r#.#Z##	186.70
234	30	2.0	8	0.50 - 0.60	16 - 18	234d30e2.0r#.#Z##	207.40
234	30	3.0	8	0.70 - 1.00	16 - 18	234d30e3.0r#.#Z##	243.70
234	30	4.0	8	1.10 - 1.50	15 - 16	234d30e4.0r#.#Z##	274.80
234	30	5.0	8	1.60 - 1.80	15 - 16	234d30e5.0r#.#Z##	316.30
234	30	6.0	8	1.90 - 2.30	14 - 16	234d30e6.0r#.#Z##	362.90
234	30	7.0	8	2.40 - 2.80	12 - 14	234d30e7.0r#.#Z##	414.80
234	30	8.0	8	2.90 - 3.30	12 - 14	234d30e8.0r#.#Z##	430.30
234	30	9.0	8	3.40 - 3.50	12 - 14	234d30e9.0r#.#Z##	466.60



Typ	d1	e	d2	r	Z	Artikelcode	EUR
234	30	10.0	8	3.60 - 4.	12 - 14	234d30e10.0r#.#Z##	487.30
234	40	1.0	10	0.10 - 0.2	18 - 20	234d40e1.0r#.#Z##	181.50
234	40	1.5	10	0.30 - 0.40	18 - 20	234d40e1.5r#.#Z##	207.40
234	40	2.0	10	0.50 - 0.60	18 - 20	234d40e2.0r#.#Z##	228.20
234	40	3.0	10	0.70 - 1.00	18 - 20	234d40e3.0r#.#Z##	269.70
234	40	4.0	10	1.10 - 1.50	16 - 18	234d40e4.0r#.#Z##	305.90
234	40	5.0	10	1.60 - 1.80	16 - 18	234d40e5.0r#.#Z##	357.80
234	40	6.0	10	1.90 - 2.30	16 - 18	234d40e6.0r#.#Z##	414.80
234	40	7.0	10	2.40 - 2.80	16 - 18	234d40e7.0r#.#Z##	487.30
234	40	8.0	10	2.90 - 3.30	16 - 18	234d40e8.0r#.#Z##	508.10
234	40	9.0	10	3.40 - 3.50	15 - 16	234d40e9.0r#.#Z##	549.60
234	40	10.0	10	3.60 - 4.0	15 - 16	234d40e10.0r#.#Z##	565.10
234	40	11.0	10	4.10 - 4.5	14 - 16	234d40e11.0r#.#Z##	622.10
234	40	12.0	10	4.60 - 5.0	12	234d40e12.0r#.#Z##	642.80
234	50	1.5	13	0.30 - 0.40	22	234d50e1.5r#.#Z##	241.70
234	50	2.0	13	0.50 - 0.60	22	234d50e2.0r#.#Z##	264.50
234	50	3.0	13	0.70 - 1.00	22	234d50e3.0r#.#Z##	321.50
234	50	4.0	13	1.10 - 1.50	22	234d50e4.0r#.#Z##	394.10
234	50	5.0	13	1.60 - 1.80	22	234d50e5.0r#.#Z##	430.30
234	50	6.0	13	1.90 - 2.30	20	234d50e6.0r#.#Z##	471.90
234	50	8.0	13	2.40 - 3.30	20	234d50e8.0r#.#Z##	565.10
234	50	10.0	13	3.40 - 4.0	20	234d50e10.0r#.#Z##	637.70
234	50	12.0	13	4.10 - 5.0	18	234d50e12.0r#.#Z##	642.80
234	63	1.5	16	0.30 - 0.40	26	234d63e1.5r#.#Z##	259.20
234	63	2.0	16	0.50 - 0.60	24	234d63e2.0r#.#Z##	285.20
234	63	3.0	16	0.70 - 1.00	24	234d63e3.0r#.#Z##	345.40
234	63	4.0	16	1.10 - 1.50	24	234d63e4.0r#.#Z##	420.00
234	63	5.0	16	1.60 - 1.80	24	234d63e5.0r#.#Z##	445.90
234	63	6.0	16	1.90 - 2.30	24	234d63e6.0r#.#Z##	523.70
234	63	8.0	16	2.40 - 3.30	22	234d63e8.0r#.#Z##	630.40
234	63	10.0	16	3.40 - 4.0	22	234d63e10.0r#.#Z##	705.10
234	63	12.0	16	4.10 - 5.0	22	234d63e12.0r#.#Z##	777.60

Bitte bei Bestellung Radius und Zähnezahl angeben.

Weitere Abmessungen auf Anfrage lieferbar.

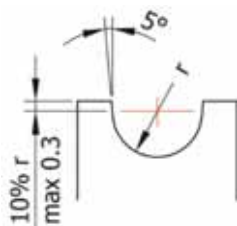

www.klingseisen.de



Tools & solutions

Lieferprogramm:

Bohrwerkzeuge
Gewindewerkzeuge
Reibwerkzeuge
Senkwerkzeuge
Fräswerkzeuge
Sägewerkzeuge
Spannwerkzeuge
Messwerkzeuge
Decolletagewerkzeuge
Rändelwerkzeuge
Montagewerkzeuge
Wendeplattenwerkzeuge
Schleifwerkzeuge
Betriebseinrichtungen
Antriebstechnik
Schmierstoffe
Klebstoffe
Druckluftwerkzeuge
Beschriftungswerkzeuge
Räumwerkzeuge
Entgratwerkzeuge
Feilen
Dienstleistungen

Brunnenstraße 2 · 78554 Aldingen · Tel. (07424) 98192-0

Fax. (07424) 84601 · info@klingseisen.de