

# BARREL-SHAPED ENDMILLS

## Quick Tool Selector Guide

Metric Catalog



**MACHINING IN TELLIGENTLY**

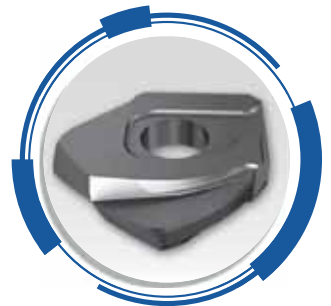

SOLID  
CARBIDE  
ENDMILLS

MULTI-MASTER  
HEADS

ONE INSERT  
CUTTERS

# Barrel Shaped Endmills

## Solid Carbide Endmills



**Solid Carbide  
Oval-Shaped**  
Endmills for 3D Profiling

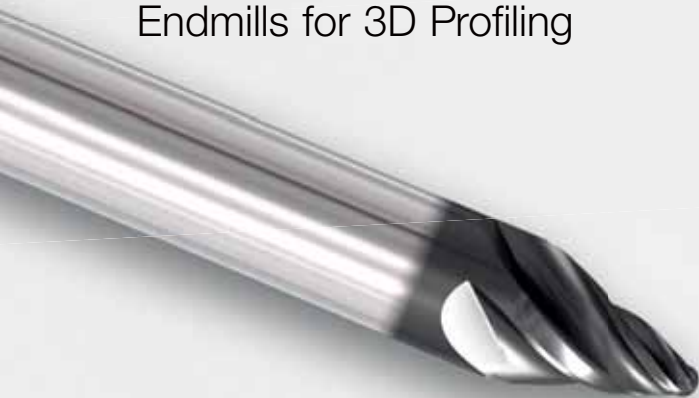

**Solid Carbide Taper-Shaped**  
Endmills for 3D Profiling



**Solid Carbide Lens-Shaped**  
Endmills for 3D Profiling



**Multi-Master**  
Interchangeable  
Carbide Heads



**Oval-Shaped**  
Solid Carbide Heads



**Lens-Shaped**  
Solid Carbide Heads

**One Insert**  
Cutters

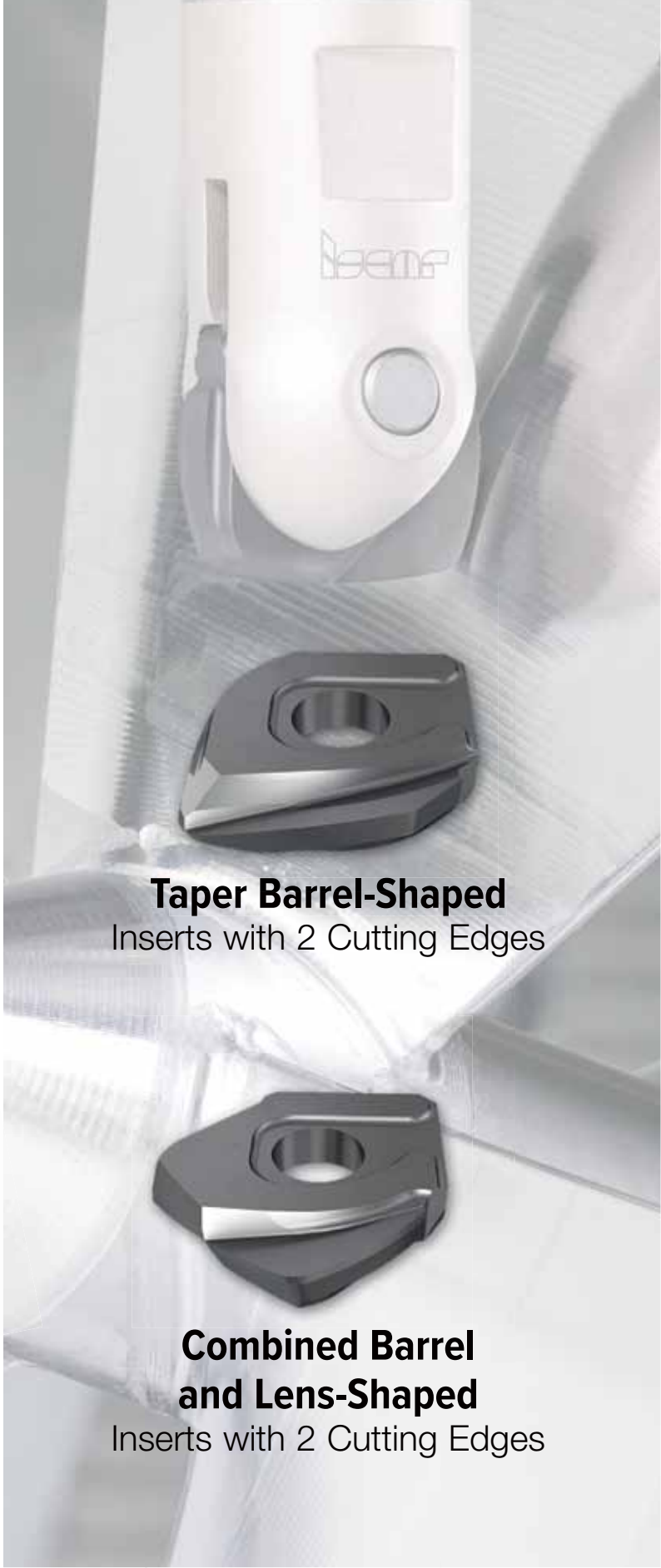

**Taper Barrel-Shaped**  
Inserts with 2 Cutting Edges



**Combined Barrel  
and Lens-Shaped**  
Inserts with 2 Cutting Edges

# Barrel Shaped Endmills

## Expanding the Boundaries of Barrel Endmill Applications

Endmills that feature a cutting edge being the segment of a large-diameter arc were introduced approximately 25 years ago.

As the cutting-edge shape of these endmills is reminiscent of a barrel profile, terms such as "barrel milling cutters", "barrel endmills" became common when referring to these types of endmills. At first, the use of these barrel-shaped mills was limited to a few specific applications, such as machining 3D surfaces of complex dies and turbomachinery components.

However, advances in 5-axis machining and in CAM systems have significantly expanded the boundaries of barrel endmill applications.

Traditionally, ball-nose and toroidal cutters perform these machining operations.

The large-diameter arc of the endmills cutting edge provides substantial reduction of the cusp height generated between passes machined by a ball-nose or toroidal cutter.

Another advantage of this type of cutting edge versus ball-nose and toroidal cutters is a significant increase in the distance between passes (a stepover or a stepdown, depending on the direction of a cutter displacement after every pass), at least four times more without the degradation of the surface finish parameters. This implies that the number of passes and machining time can be substantially reduced. Increasing the distance between passes also improves tool life and therefore decreases tool cost per part.

The main consumers of "cutting barrels" are producers of aerospace, die and mold, medical, turbine and compressor components. Cutting tool companies have strengthened their efforts to develop and manufacture more advanced barrel endmill designs to meet increased customer demands. Some of ISCAR's latest product such as, barrel endmills, MULTI-MASTER and one insert cutter families show good examples of this trend.



ISCAR's program for barrel-shaped cutters comprises tools in the following design configuration:

- **Solid carbide endmills.**
- **Assembled endmills that mount MULTI-MASTER interchangeable carbide heads, and indexable endmills.**

These cutters differ in their capabilities and field of application. The figures and tables provide general data that relate to the cutters.

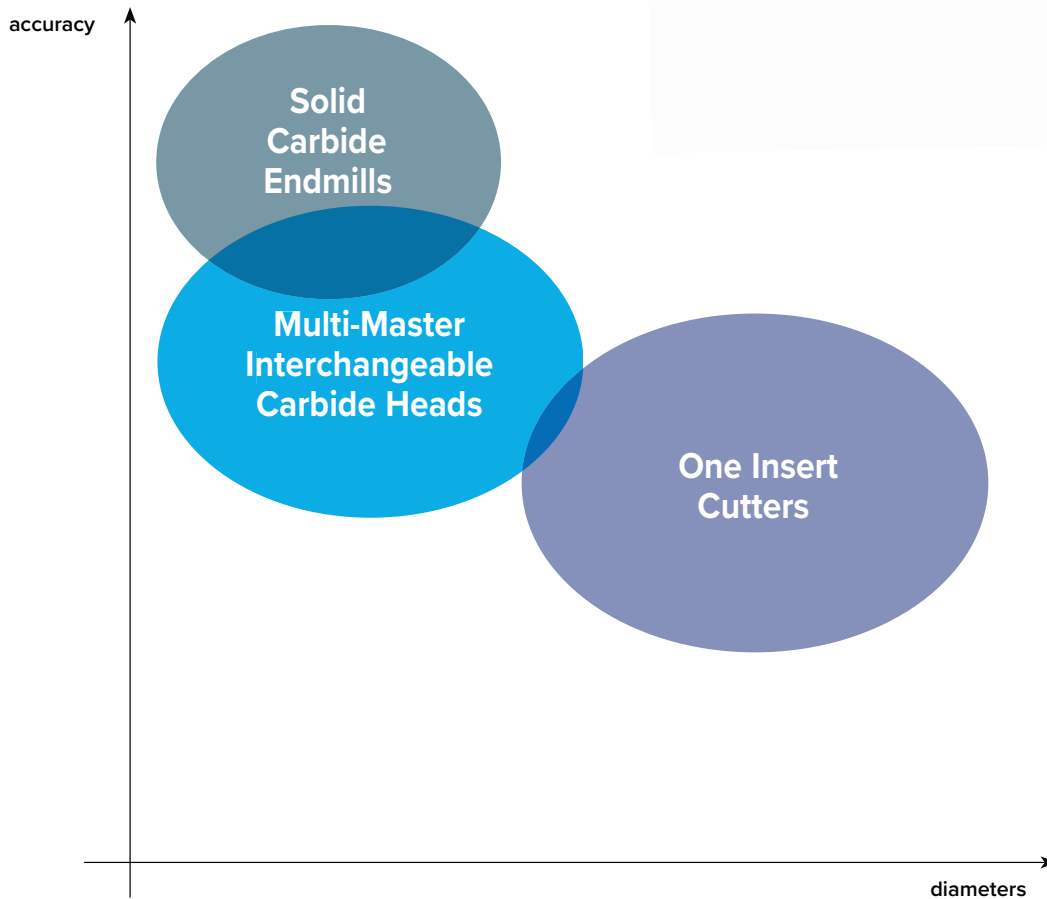

**Table 1 - the Main Parameters of Barrel-Shaped Cutters**

Type	Parameters				
	Diameters Range (mm)	Geometry			Number of Teeth
		Barrel	Lens	Taper	
Solid Carbide Endmills	8-12	•	•	•	2-6
MM Cutters*	8-16	•	•		2-6
One Insert Cutters	16-25	•	•	•	2

\* MM cutters - MULTI-MASTER cutters

# Barrel Shaped Endmills

## The Design Concept Advantages

Solid carbide design ensures the highest tool accuracy. ISCAR offers oval and lens shaped solid carbide endmills in diameter ranges of 8 - 12mm.

In addition, barrel endmills have been manufactured as interchangeable carbide heads with MULTI-MASTER threaded adaptations in the diameter ranges of 8 - 16mm.

MULTI-MASTER's distinctive "no setup time" phenomenon, which enables the replacement of a worn head without removing the tool from the machine spindle, is effective in barrel tool applications for semi-finish and finish milling operations.

The one insert cutter design enables cost-efficient increase of the cutter diameter range of up to 25mm. According to this concept barrel-shaped inserts are mounted on endmills.

### Multi-Master Interchangeable Carbide Heads

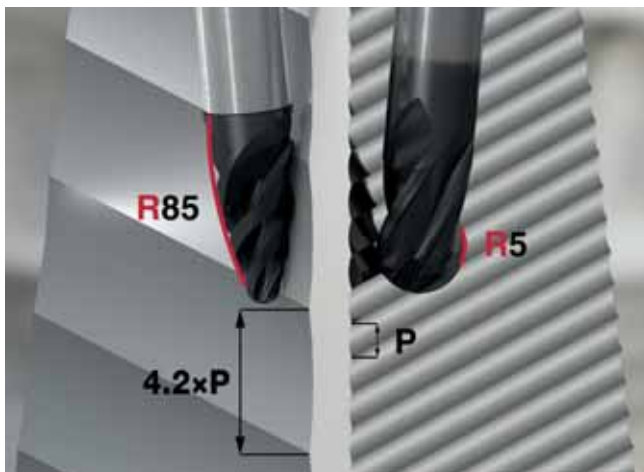

### Estimated Scallop when Milling with Barrel-Shaped Cutters

Oval-Shaped Solid Carbide Heads						
Diameter (mm)	Radius (mm)	Scallops Height (mm)				
		0.002	0.004	0.01	0.015	
8	80	1.13	1.6	2.53	3.1	stepsize $a_p$ (mm)
10	85	1.17	1.65	2.61	3.19	
12	75	1.1	1.55	2.45	3	
16	75	1.1	1.55	2.45	3	

Lens-Shaped Solid Carbide Heads						
Diameter (mm)	Radius (mm)	Scallops Height (mm)				
		0.002	0.004	0.01	0.015	
8	16	0.51	0.72	1.13	1.39	stepsize $a_e$ (mm)
10	20	0.57	0.8	1.26	1.55	
12	24	0.62	0.88	1.39	1.7	
16	32	0.72	1.01	1.6	1.96	

## Solid Carbide Endmills

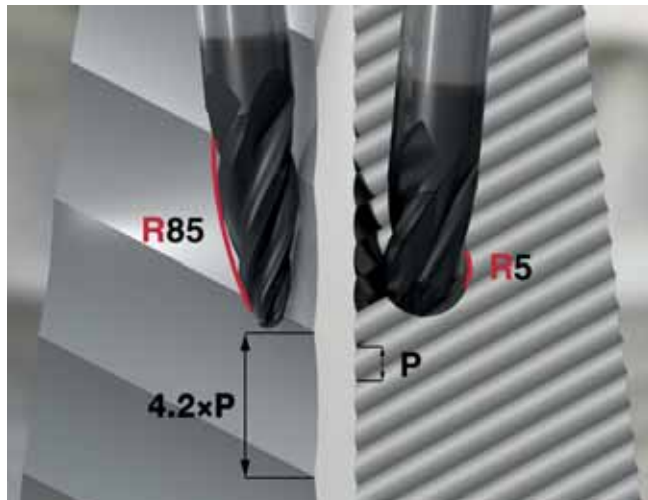

### Estimated Scallop when Milling with Barrel-Shaped Cutters

		Tapered-Shaped Endmills				
Diameter (mm)	Radius (mm)	Scallops Height (mm)				
		0.002	0.004	0.01	0.015	
8	250	2	2.83	4.47	5.48	stepsize $a_p$ (mm)
10	250	2	2.83	4.47	5.48	
12	250	2	2.83	4.47	5.48	

		Oval-Shaped Endmills				
Diameter (mm)	Radius (mm)	Scallops Height (mm)				
		0.002	0.004	0.01	0.015	
8	90	1.2	1.7	2.68	3.29	stepsize $a_p$ (mm)
10	85	1.17	1.65	2.61	3.19	
12	80	1.13	1.6	2.53	3.1	

		Lens-Shaped Endmills				
Diameter (mm)	Radius (mm)	Scallops Height (mm)				
		0.002	0.004	0.01	0.015	
8	16	0.51	0.72	1.13	1.39	stepsize $a_e$ (mm)
10	20	0.57	0.8	1.26	1.55	
12	25	0.63	0.89	1.41	1.73	

# Barrel Shaped Endmills

## One Insert Cutters

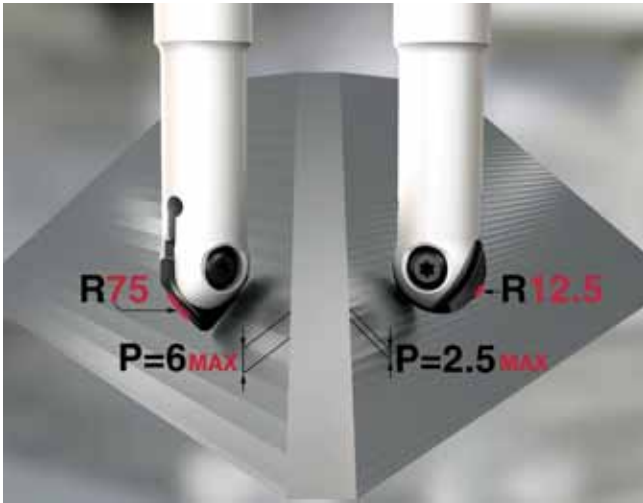

## Estimated Scallop when Milling with Barrel-Shaped Cutters

HLB - Combined Barrel and Lens-Shaped Inserts With 2 Cutting Edges													
Scallops Height (mm)													
Diameter (mm)	Barrel	Lens	Barrel					Lens					
	Radius (mm)		0.25	0.4	0.5	1	1.5	0.5	0.75	1	1.5	2	
16	16	32	0.5	1.25	1.95	7.8	17.6	1	2.2	3.9	7.8	15.6	stepsize $a_p/a_e$ (mm)
20	20	40	0.4	1	1.56	6.25	14.1	0.4	1	1.56	6.25	12.5	
25	25	50	0.3	0.8	1.25	5	11.25	0.3	0.8	1.25	5	11.25	

HCT - Taper Barrel-Shaped Inserts With 2 Cutting Edges						
Scallops Height (mm)						
Diameter (mm)	Radius (mm)	0.6	1.2	1.8	2.4	
16	45	1	4	9	16	stepsize $a_p$ (mm)
20	60	0.75	3	6.75	12	
25	75	0.6	2.4	5.4	9.6	



**oval-shaped  
taper-shaped**

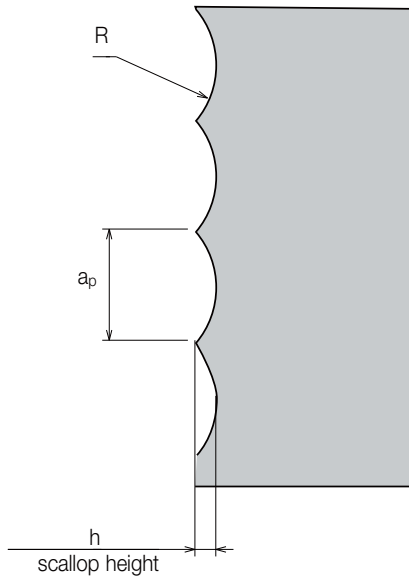

**lens-shaped**

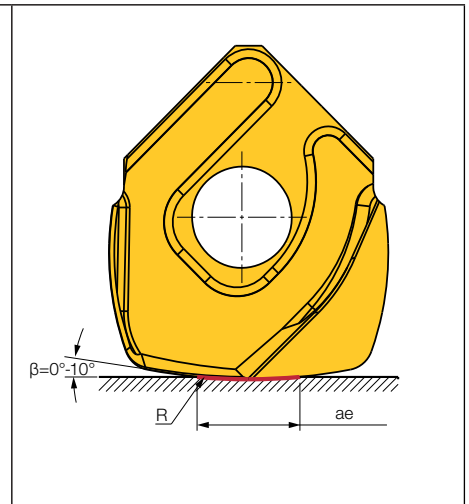
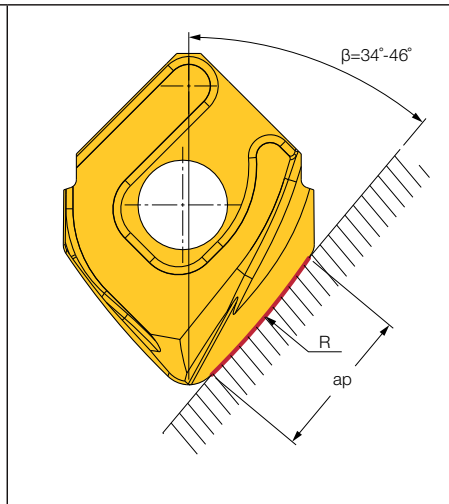
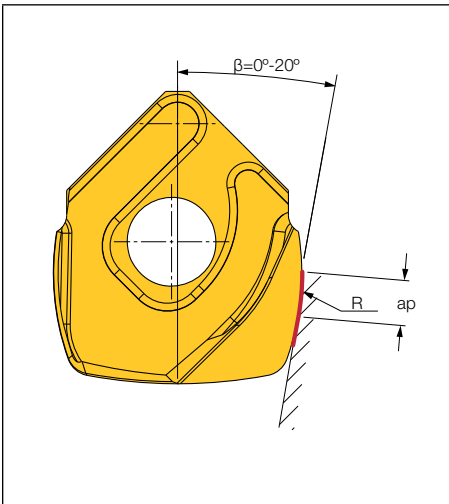
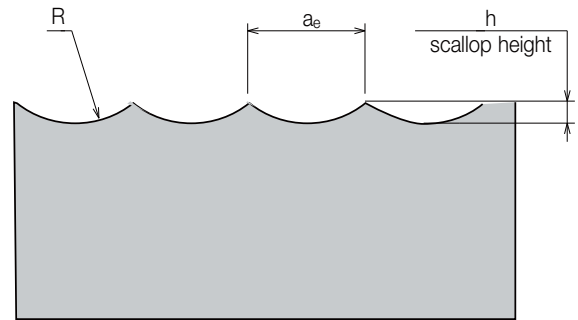

A scallop height can be calculated as a function of  $a_p/a_e$  and  $R$  by use of the equation in the table below

Insert/Application		H
HLB	milling by bottom edge	$0.5x(2xR - \sqrt{((2xR)^2 - a_e^2)})$
	milling by peripheral edge	$0.5x(2xR - \sqrt{((2xR)^2 - a_p^2)})$
HCT	milling by taper edge	$0.5x(2xR - \sqrt{((2xR)^2 - a_p^2)})$

R-radius of appropriate (bottom or peripheral) cutting edge

**Recommended Range for Milling by use of Barrel-Shaped Inserts**

Insert	Angle $\beta$ , Working Range
HLB - Barrel	0°-20°
HLB - Lens	0°-10°
HCT - Taper	34°-46°

# Barrel Shaped Endmills

**NEOBARREL**  
PROFILE MILLING

**EOB**  
Solid Carbide Oval-Shaped  
(Barrel) Endmills for 3D Profiling

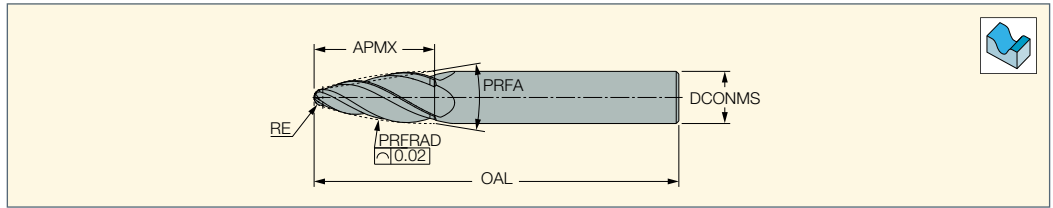

Designation	Dimensions								Tough ← Hard		
	DCONMS	RE	PRFRAD	APMX	PRFA	NOF <sup>(1)</sup>	OAL	Shank <sup>(2)</sup>	IC08	IC902	IC602
EOB-R1R90A24/7-4C08-63	8.00	1.00	90.00	24.50	14.88	4	63.00	C		•	
EOB-R2R90A20/7-4C08-63	8.00	2.00	90.00	21.50	12.18	4	63.00	C		•	
EOB-AL-R2R85A20/9-4C10-72	10.00	2.00	85.00	21.00	18.68	4	72.00	C	•		
EOB-R2R85A24/8-4C10-72	10.00	2.00	85.00	24.50	15.46	4	72.00	C		•	
EOB-R3R85A21/6-4C10-72	10.00	3.00	85.00	21.30	12.62	4	72.00	C		•	
EOB-R2R80A27/9-4C12-83	12.00	2.00	80.00	27.10	18.38	4	83.00	C		•	
EOB-AL-R3R85A24/8-4C12-83	12.00	3.00	85.00	25.00	16.12	4	83.00	C	•		
EOB-R3R80A24/8-4C12-83	12.00	3.00	80.00	24.50	15.98	4	83.00	C		•	
EOB-R4R80A21/6-8C12-83	12.00	4.00	80.00	21.50	13.10	8	83.00	C			•
EOB-R4R80A21/7-4C12-83	12.00	4.00	80.00	21.50	13.10	4	83.00	C		•	

<sup>(1)</sup> Number of flutes

<sup>(2)</sup> C-Cylindrical



**MULTI-MASTER**  
INDEXABLE SOLID CARBIDE LINE  
**NEOBARREL**  
PROFILE MILLING

**MM EOB**  
Interchangeable Oval-Shaped  
(Barrel) Solid Carbide  
Heads for 3D Profiling

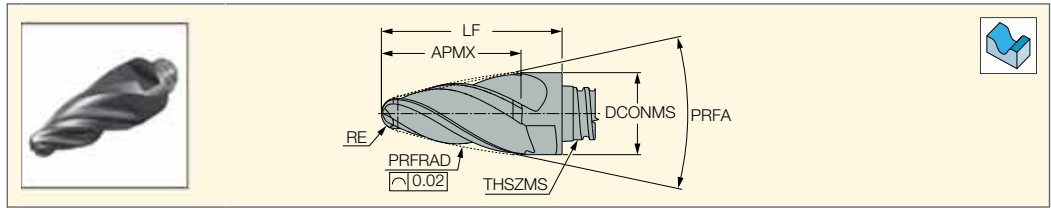

Designation	Dimensions								IC908
	PRFRAD	RE	APMX	PRFA	THSZMS	NOF <sup>(1)</sup>	DCONMS	LF	
MM EOB08R1.5R80A13-4T05	80.00	1.50	14.20	24.00	T05	4	8.00	18.00	●
MM EOB08R1.5R80A13-6T05	80.00	1.50	14.10	24.00	T08	6	8.00	18.00	●
MM EOB10R2.0R85A16-4T06	85.00	2.00	16.50	24.00	T06	4	10.00	22.00	●
MM EOB10R2.0R85A16-6T06	85.00	2.00	16.50	24.00	T06	6	22.00	22.00	●
MM EOB12R2.0R75A21-4T08	75.00	2.00	21.30	24.00	T08	4	12.00	27.00	●
MM EOB12R2.0R75A21-6T08	75.00	2.00	21.30	24.00	T08	6	27.00	27.00	●
MM EOB16R3.0R75A26-4T10	75.00	3.00	27.00	24.00	T10	4	16.00	33.50	●
MM EOB16R3.0R75A26-6T10	75.00	3.00	27.00	24.00	T10	6	33.50	33.50	●

<sup>(1)</sup> Number of flutes

**MULTI-MASTER**  
INDEXABLE SOLID CARBIDE LINE  
**NEOBARREL**  
PROFILE MILLING

**MM EOBA**  
Interchangeable Oval-Shaped  
(Barrel) Solid Carbide Heads  
for 3D Aluminum Profiling

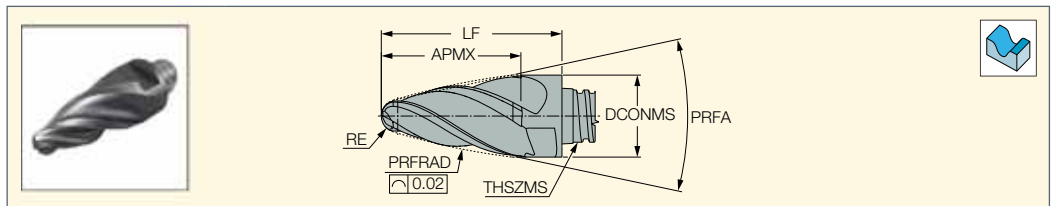

Designation	Dimensions								IC08
	PRFRAD	RE	APMX	PRFA	THSZMS	NOF <sup>(1)</sup>	DCONMS	LF	
MM EOBA08R1.5R80A13-4T05	80.00	1.50	14.20	24.00	T05	4	8.00	18.00	●
MM EOBA10R2.0R85A16-4T06	85.00	2.00	16.50	24.00	T06	4	10.00	22.00	●
MM EOBA12R2.0R75A21-4T	75.00	2.00	21.30	24.00	T08	4	12.00	27.00	●
MM EOBA16R3.0R75A26-4T10	75.00	3.00	27.00	24.00	T10	4	16.00	33.50	●

<sup>(1)</sup> Number of flutes

# Barrel Shaped Endmills

**SOLIDMILL**  
PREMIUM LINE  
**NEOBARREL**  
PROFILE MILLING

**ELB**  
Solid Carbide Lens-Shaped  
(Barrel) Endmills for 3D Profiling

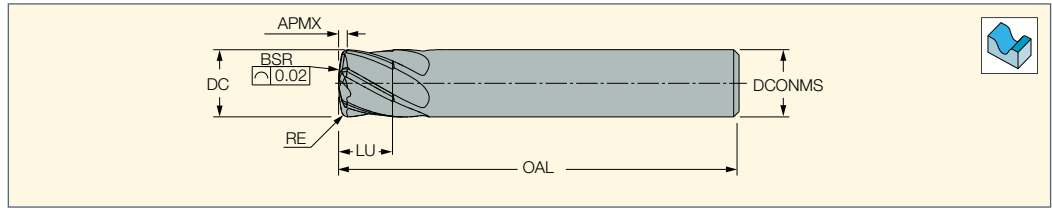

Designation	Dimensions									IC902
	DC	BSR	RE	LU	APMX	DCONMS	NOF <sup>(1)</sup>	OAL	Shank <sup>(2)</sup>	
ELB-R0.75R16A5-6C8-63	8.00	15.00	0.75	5.00	1.10	8.00	6	63.00	C	●
ELB-R1R20A7-6C10-72	10.00	20.00	1.00	7.00	1.43	10.00	6	72.00	C	●
ELB-R1R25A9-6C12-83	12.00	25.00	1.00	9.00	1.53	12.00	6	83.00	C	●

<sup>(1)</sup> Number of flutes

<sup>(2)</sup> C-Cylindrical

**MULTI-MASTER**  
INDEXABLE SOLID CARBIDE LINE  
**NEOBARREL**  
PROFILE MILLING

**MM ELB**  
Interchangeable Lens-Shaped  
(Barrel) Solid Carbide  
Heads for 3D Profiling

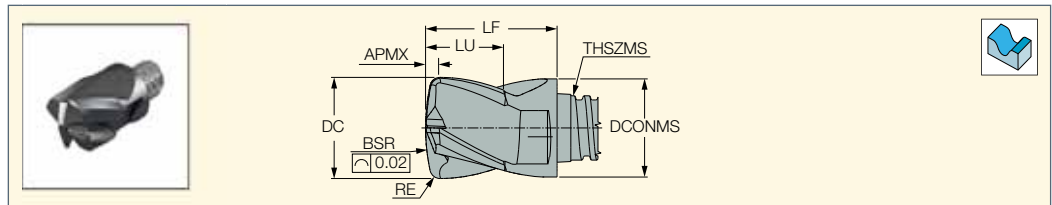

Designation	Dimensions									IC908
	DC	BSR	RE	LU	APMX	THSZMS	DCONMS	NOF <sup>(1)</sup>	LF	
MM ELB08R16A05-4T05	8.00	16.00	0.50	5.50	0.90	T05	8.00	4	10.00	●
MM ELB10R20A07-4T06	10.00	20.00	1.00	7.50	1.42	T06	10.00	4	13.00	●
MM ELB12R24A09-4T08	12.00	24.00	1.00	9.00	1.55	T08	12.00	4	16.50	●
MM ELB16R32A12-4T10	16.00	32.00	1.00	12.00	1.80	T10	16.00	4	20.50	●

<sup>(1)</sup> Number of flutes

**MULTI-MASTER**  
INDEXABLE SOLID CARBIDE LINE  
**NEOBARREL**  
PROFILE MILLING

**MM ELBA**  
Interchangeable Lens-Shaped  
(Barrel) Solid Carbide Heads  
for 3D Aluminum Profiling

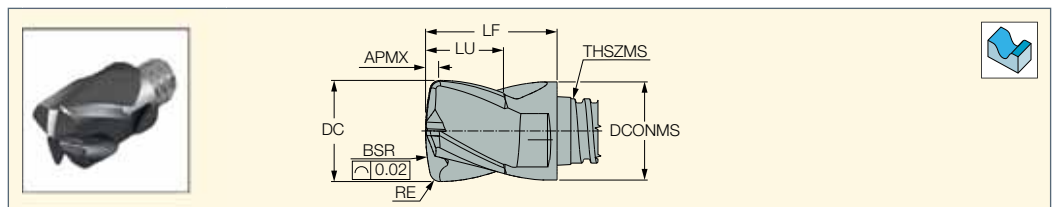

Designation	Dimensions									IC08
	DC	BSR	RE	LU	APMX	THSZMS	DCONMS	NOF <sup>(1)</sup>	LF	
MM ELBA08R16A05-4T05 08	8.00	16.00	0.50	5.50	0.90	T05	8.00	4	10.00	●
MM ELBA10R20A07-4T06	10.00	20.00	1.00	7.50	1.42	T06	10.00	4	13.00	●
MM ELBA12R24A09-4T08 08	12.00	24.00	1.00	9.00	1.55	T08	12.00	4	16.50	●
MM ELBA16R32A12-4T10	16.00	32.00	1.00	12.00	1.80	T10	16.00	4	20.50	●

<sup>(1)</sup> Number of flutes

**SOLIDMILL**  
PREMIUM LINE  
**NEOBARREL**  
PROFILE MILLING

**ETB**  
Solid Carbide Taper-Shaped  
(Barrel) Endmills for 3D Profiling

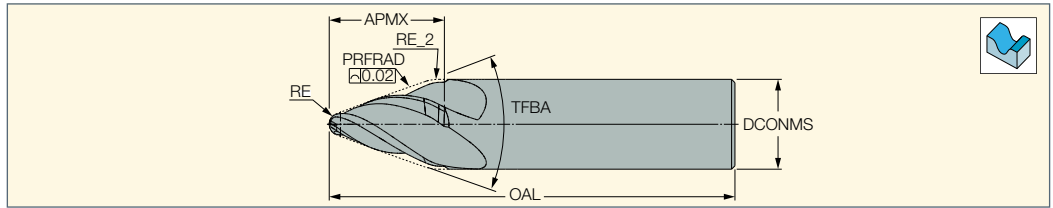

Designation	Dimensions									IC902
	PRFRAD	RE_2	RE	APMX	TFBA	DCONMS	NOF <sup>(1)</sup>	OAL	Shank <sup>(2)</sup>	
<b>ETB-R1R250A10/20-4C08-63</b>	250.00	4.00	1.00	10.00	40.00	8.00	4	63.00	C	●
<b>ETB-R2R250A11/20-4C10-72</b>	250.00	5.00	2.00	11.00	40.00	10.00	4	72.00	C	●
<b>ETB-R3R250A12/20-4C12-83</b>	250.00	6.00	3.00	12.00	40.00	12.00	4	83.00	C	●

<sup>(1)</sup> Number of flutes

<sup>(2)</sup> C-Cylindrical



# Barrel Shaped Endmills

**Table 2 - Recommended Cutting Parameters to Start**

ISO	Material	Condition	Tensile Strength (N/mm <sup>2</sup> )	Hardness HB	Material No.	Cutting Parameter Range		
						v <sub>c</sub> (m/min)	f <sub>z</sub> (mm/t)	
P	non-alloy steel and cast steel, free cutting steel	<0.25% C	annealed	420	125	1	210-300	0.005-0.01xD**
		≥0.25% C	annealed	650	190	2	200-250	0.005-0.01xD
		<0.55% C	quenched and tempered	850	250	3	160-240	0.004-0.009xD
			annealed	750	220	4	160-240	0.003-0.008xD
			quenched and tempered	1000	300	5	140-200	0.004-0.009xD
	low alloy and cast steel (less than 5% of alloying elements)	annealed	600	200	6	160-240	0.003-0.008xD	
		quenched and tempered	930	275	7	120-200	0.003-0.008xD	
			1000	300	8	130-200	0.003-0.008xD	
			1200	350	9	140-200	0.003-0.008xD	
	high alloyed steel, cast steel and tool steel	annealed	680	200	10	130-200	0.003-0.008xD	
		quenched and tempered	1100	325	11	70-130	0.002-0.007xD	
	stainless steel and cast steel	ferritic / martensitic	680	200	12	80-175	0.002-0.007xD	
		martensitic	820	240	13	60-165	0.002-0.007xD	
M	stainless steel and cast steel	austenitic, duplex	600	180	14	60-110	0.002-0.007xD	
K	gray cast iron (GG)	ferritic / pearlitic		180	15	150-275	0.005-0.01xD	
		pearlitic / martensitic		260	16	150-265	0.005-0.01xD	
	nodular cast iron (GGG)	ferritic		160	17	150-200	0.005-0.01xD	
		pearlitic		250	18	90-150	0.004-0.009xD	
	malleable cast iron	ferritic		130	19	150-200	0.005-0.01xD	
		pearlitic		230	20	90-150	0.004-0.009xD	
S	high temperature alloys	Fe based	annealed		200	31	20-45	0.002-0.004xD
			hardened		280	32	20-35	0.002-0.004xD
		Ni or Co based	annealed		250	33	20-35	0.002-0.004xD
			hardened		350	34	20-35	0.002-0.004xD
			cast		320	35	60-90	0.002-0.004xD
	titanium alloys	pure	400	190	36	60-90	0.002-0.004xD	
		alpha+beta alloys, hardened	1050	310	37	60-90	0.002-0.004xD	
H	hardened steel	hardened		55 HRC	38	40-80	0.001-0.003xD	
		hardened		60 HRC	39			
	chilled cast iron	cast		400	40	40-80	0.001-0.003xD	
	cast iron	hardened		55 HRC	41	40-80	0.001-0.003xD	

\* Recommended amount of material engagement should not exceed 0.3mm

\*\* D - nominal diameter of solid carbide endmill (MM head)

**BALLPLUS**

**HLB-QF**

Combined Barrel and Lens-shaped Inserts with 2 Cutting Edges

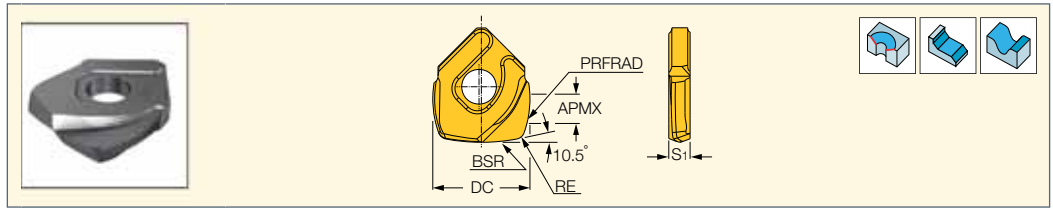

Designation	Dimensions						IC908
	DC	APMX	S1	RE	BSR	PRFRAD	
HLB D160-QF	16.00	7.00	3.37	1.50	32.00	16.00	•
HLB D200-QF	20.00	9.00	4.65	2.00	40.00	20.00	•
HLB D250-QF	25.00	11.00	5.40	2.50	50.00	25.00	•

• For machining recommendations, see table 3

**BALLPLUS**

**HCT-QF**

Taper Barrel-Shaped Inserts with 2 Cutting Edges

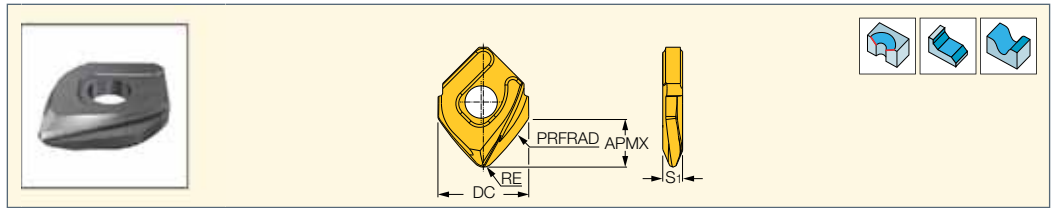

Designation	Dimensions						IC908
	DC	APMX	S1	RE	PRFRAD		
HCT D160-QF	16.00	8.50	3.37	1.60	45.00	•	
HCT D200-QF	20.00	10.50	4.65	2.00	60.00	•	
HCT D250-QF	25.00	12.50	5.40	2.50	75.00	•	

• For machining recommendations, see table 3

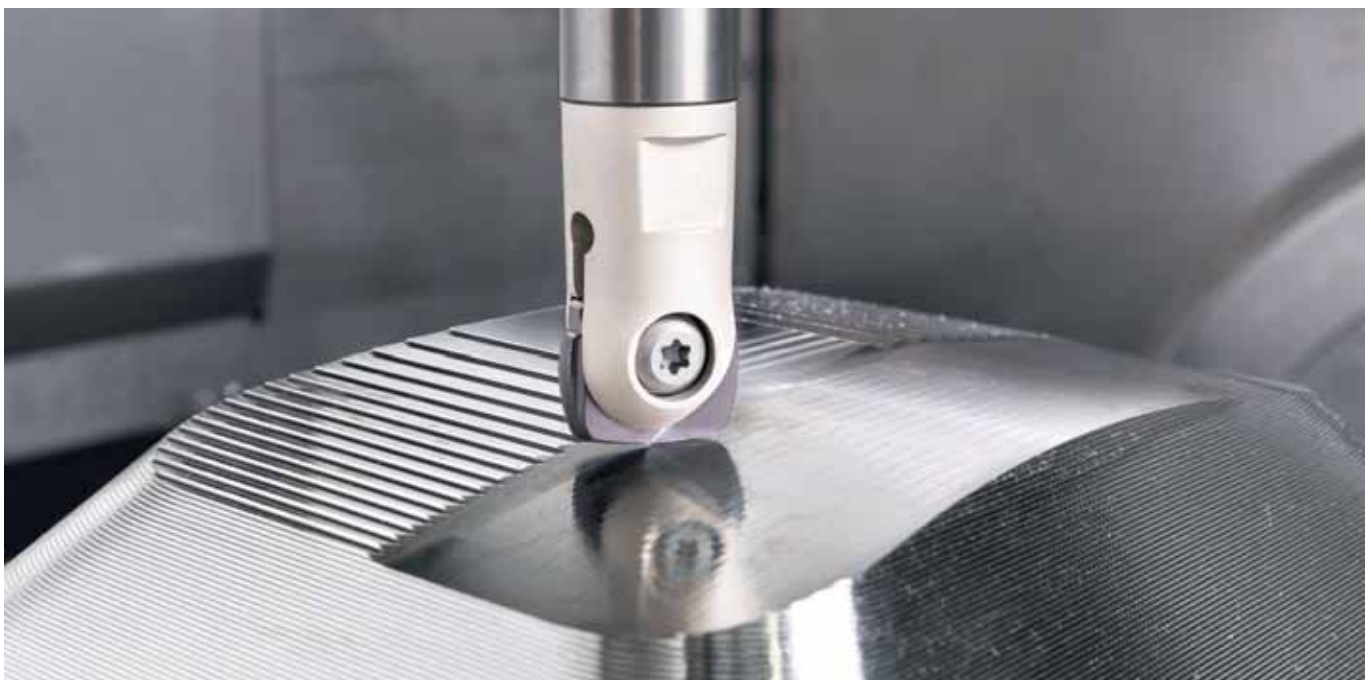

# Barrel Shaped Endmills

**Table 3 - average cutting data when milling with barrel-shaped inserts**

ISO	Material	Material Group No.	Hardness, HB	Typical Representative		Carbide Grade	Cutting Speed $v_{c0}$ (mm/min)	Feed $f_z$ (mm/t)			Depth of Cut (mm)			Coolant
				AISI/SAE/ASTM	DIN W.-Nr.			HCT Taper	HLB Barrel	HLB Lens	$a_e$	$a_e$	$a_p$	
											HCT Taper	HLB Barrel	HLB Lens	
P	non-alloy steel and cast steel, free cutting steel	1-5	130-180	1020	1.0402	IC908	500-600	0.1-0.2	0.12-0.25	0.15-0.3	0.1	0.1	0.1	Dry
	low alloy and cast steel (less than 5% of alloying elements)	6-8	260-300	4340	1.6582	IC908	500-600	0.1-0.2	0.12-0.25	0.15-0.3	0.1	0.1	0.1	Dry
		9	35-42** HRC	3135	1.5710	IC908	400-500	0.1-0.2	0.12-0.25	0.15-0.3	0.1	0.1	0.1	Dry
	high alloyed steel, cast steel and tool steel	10-11	200-220	H13	1.2344	IC908	500-600	0.1-0.2	0.12-0.25	0.15-0.3	0.1	0.1	0.1	Dry
	stainless steel and cast steel	12-13	200	420	1.4021	IC908	500-600	0.1-0.2	0.12-0.25	0.15-0.3	0.1	0.1	0.1	Dry
M	stainless steel and cast steel	14	200	304L	1.4306	IC908	400-500	0.1-0.2	0.12-0.32	0.15-0.3	0.1	0.1	0.1	Wet
K	gray cast iron (GG)	15-16	250	Class 40	0.6025 (GG25)	IC908	600-700	0.15-0.3	0.2-0.35	0.25-0.4	0.125	0.125	0.125	Dry
	nodular cast iron (GGG)	17-18	200	Class 65-45-12	0.7050 (GGG50)	IC908	500-600	0.15-0.3	0.2-0.35	0.25-0.4	0.125	0.125	0.125	
S	high temperature alloys and titanium	33-35	340	Inconel 718	2.4668	IC908	25-35	0.05-0.1	0.07-0.13	0.1-0.2	0.1	0.1	0.1	Wet
		36-37	35-40 HRC	AMS R56400	3.7165 (Ti6Al4V ELI)		40-60	0.06-0.1	0.07-0.13	0.1-0.2	0.1	0.1	0.1	
H	hardened steel	38	45-49 HRC	HARDOX 450 plate		IC908	200-300	0.05-0.1	0.1-0.15	0.15-0.2	0.075	0.075	0.075	Dry
			58-62 HRC	D2	1.2379		180-250	0.05-0.1	0.1-0.15	0.15-0.2	0.05	0.05	0.05	

\* ISCAR material group in accordance with VDI 3323 standard

\*\* Quenched and tempered

For machining in unstable conditions, the recommended cutting data should be reduced by 20-30%







Cutting speed  $v_c$  depends on the tool overhang  $H$ .  
The cutting speed can be calculated as follows:

$$v_c = v_{c0} \cdot k_H$$

**Where:**

$v_{c0}$  - cutting speed as recommended in table 3  
 $k_H$  - overhang factor in table 4

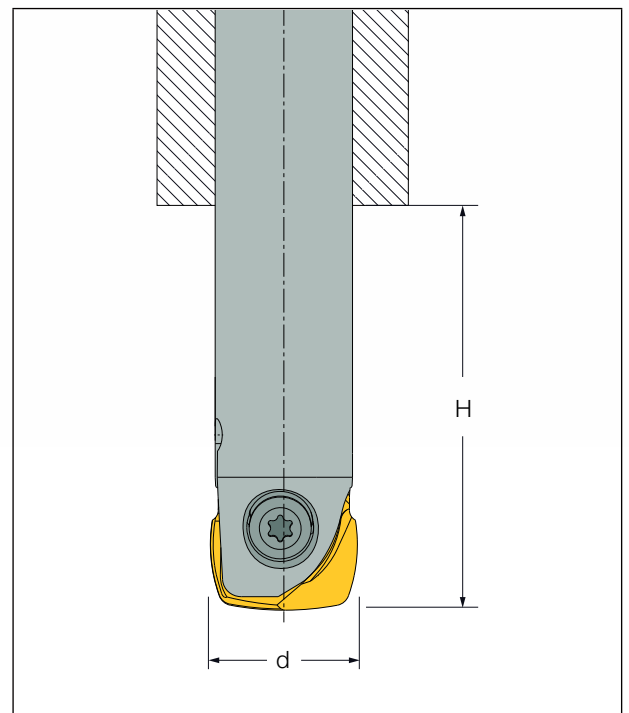

**Table 4 - Overhang Factor  $k_H$**

H/d*	Low Then 3	Over 3 Up to 5	Over 5 Up to 6	Over 6 Up to 7	Over 7
$k_H$	1	0.8	0.7	0.6	0.5

d\* - nominal tool diameter

# Barrel Shaped Endmills

## Parameters for CNC Programming of Profile Cutters by Use of a CAM System

Select a barrel tool configuration and define its dimensions as shown below:

- **Oval (Barrel) Shaped**

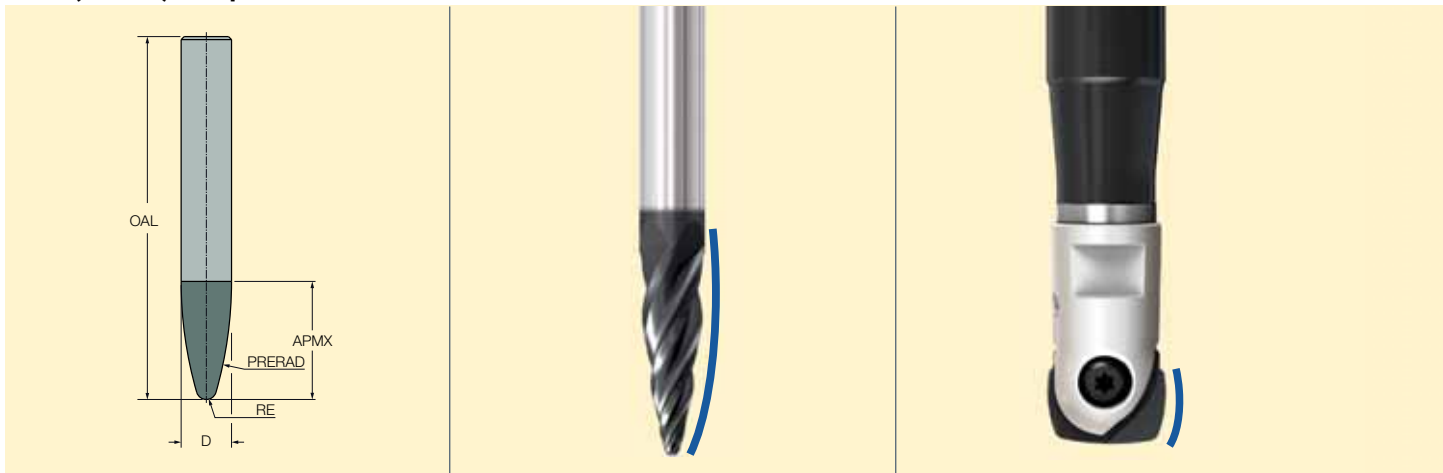

- **Taper Shaped**

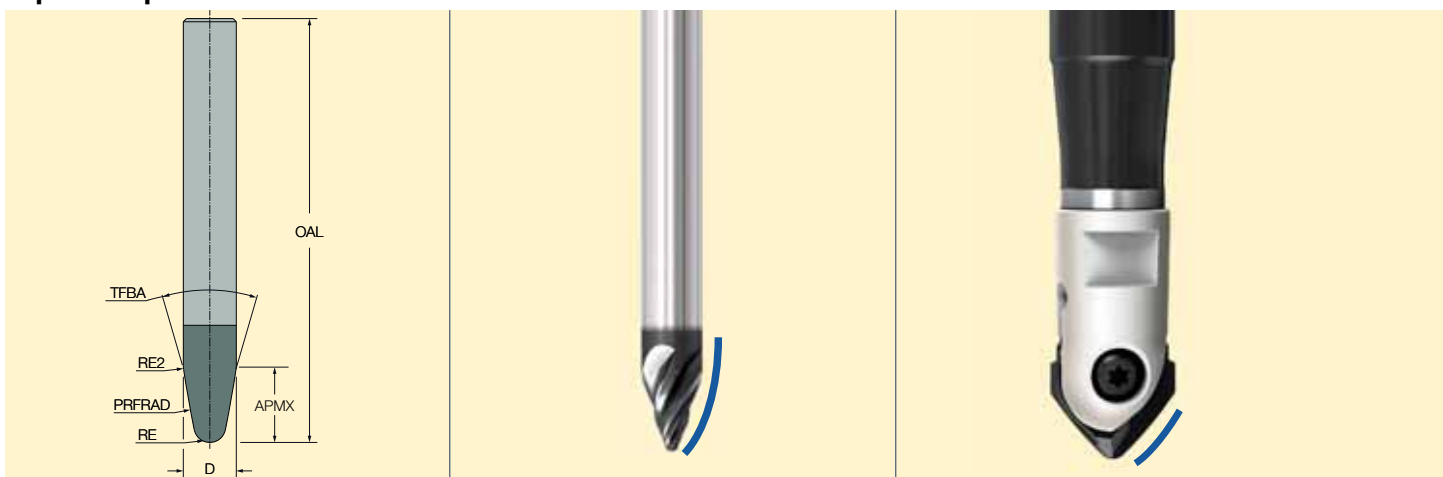

- **Lens Shaped**



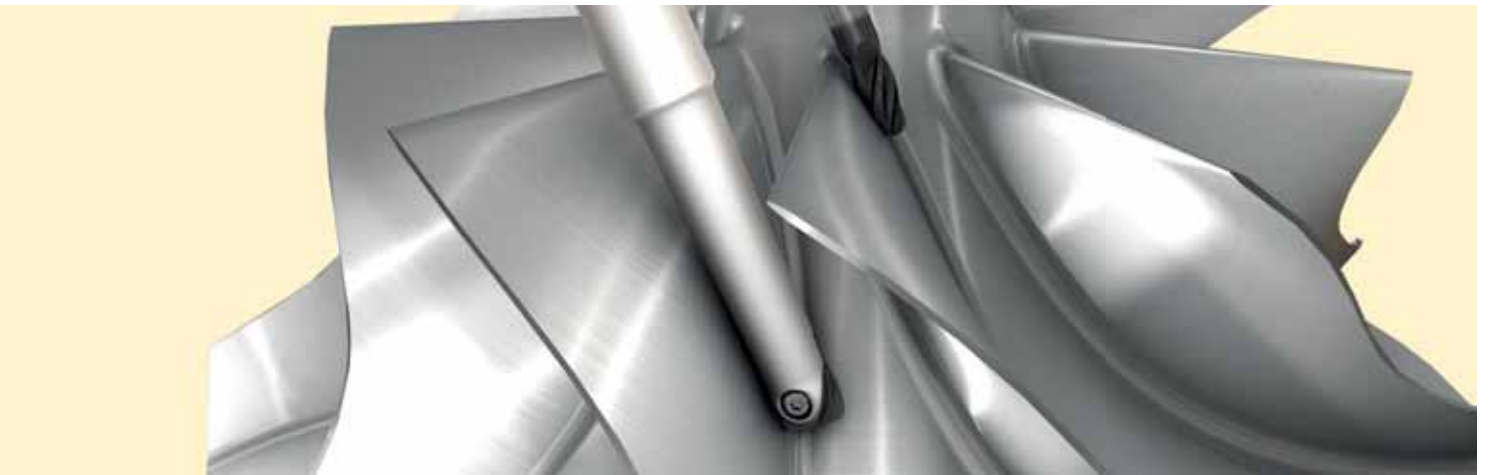

# BARREL-SHAPED ENDMILLS

## Quick Tool Selector Guide

Metric Catalog

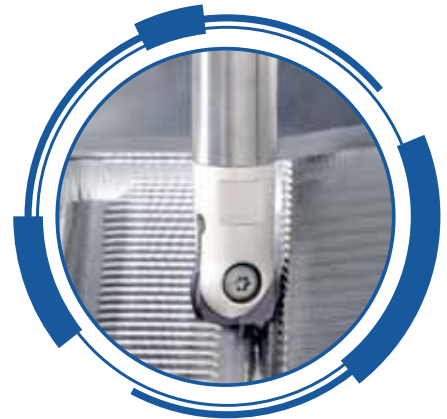
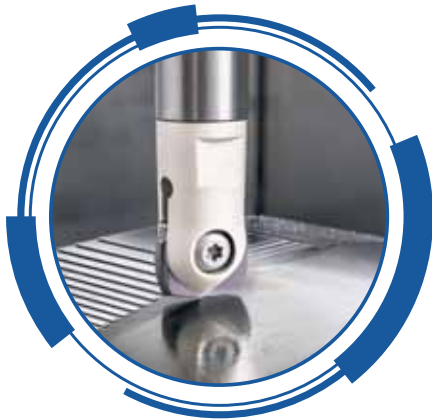

Download the  
**ISCAR WORLD APP**



**E-CAT**



Erich Klingseisen KG Brunnenstraße 2 78554 Aldingen

Tel. (07424) 98192-0  
info@klingseisen.de

Fax. (07424) 84601  
www.klingseisen.de

