

ISCAR **MULTI-MASTER** LINES

SOLID CARBIDE & INDEXABLE HEADS

Metric Catalog



MACHINING IN TELLIGENTLY





THE STANDARDS INSTITUTION OF ISRAEL



THE STANDARDS INSTITUTION OF ISRAEL



THE STANDARDS INSTITUTION OF ISRAEL



THE STANDARDS INSTITUTION OF ISRAEL



THE STANDARDS INSTITUTION OF ISRAEL

Quality Standard

ISCAR has been certified by the prestigious Standards Institution, as being in full compliance to ensure delivery of the finest quality goods. Quality control facilities include the metallurgical laboratory, raw metal testing, an online testing procedure and a machining center for tool performance testing and final product inspection. Only the finest products are packaged for entry into ISCAR's inventory.

CONTENTS

User Guide	3
-------------------------	----------

Milling

Square Shoulder Endmills

Exchangeable Solid Carbide Heads	15
Exchangeable Heads with Indexable Inserts	25

Fast Feed

Exchangeable Solid Carbide Heads	30
Exchangeable Heads with Indexable Inserts	32

Profiling

Exchangeable Solid Carbide Heads	34
Exchangeable Heads with Indexable Inserts	39
User Guide	40

Chamfering

Exchangeable Solid Carbide Heads	46
Exchangeable Heads with Indexable Inserts	51

Engraving

Exchangeable Solid Carbide Heads	52
--	----

Holemaking

Exchangeable Solid Carbide Heads	54
Exchangeable Heads with Indexable Inserts	57

Grooving

Exchangeable Solid Carbide Heads	59
Exchangeable Heads with Indexable Inserts	66

Thread Milling

Exchangeable Solid Carbide Heads	68
Exchangeable Heads with Indexable Inserts	74

Blanks	76
---------------------	-----------

Shanks	79
---------------------	-----------

M M M

MULTI-MASTER INDEXABLE HEADS

40,000 Indexable Solid Carbide Endmill Options



MIM

Scan for Short Video



Exchangeable Solid Carbide Heads

Type	Helix Angle	No. of Flutes	Diameter Range	Remarks	Page	
MM HC	10°	2	7.8-16	Slot Drill Milling Heads	24	
MM EA	45°	2, 3	6-20	High Speed Machining on Aluminum	21	
MM EA-CF	40°	3, 4	8-25	High Speed Machining on Aluminum-CHATTERFREE	22	
MM ECU	38°	3	7.7-19.7	For Keyways (DIN 6885)	15	
MM EC-3	45°	3	8-12	-	15	
MM EC-4	30°, 45°	4	5-20	-	16	
MM EC-6 MM EC-D	30°, 45° 50°	6 6, 8, 10	8-12 8-20	For Machining Hardened Steel (up to 65 HRC).	17	
MM ECK-CF	35°, 38°	5,6	8-32	For Machining Titanium Alloys	24	
MM EC-8/10	30°, 45°	8,10	16-25	-	18	
MM EFS	45°	4	8-25	Finishred	19	
MM EFS-CF	38°	4	6-25	Finishred CHATTERFREE	20	
MM EC-CF MM EC-CF-1.5xD	38° 36°, 46.5°	4, 12 4, 7, 9	8-32	CHATTERFREE	18 23	
MM ERA	45°	3	8-25	Rough Machining on Aluminum	21	
MM ERS MM ERS-1.5xD	45° 40°-47°	4, 5, 6	8-25	Rough Milling	20 22	
MM EBA	45°	2	8-25	Ball Nose for Machining Aluminum	36	
MM EPG	—	1	6,8	Engraving	52	
MM FM	—	6	10-25	Face Mill	15	
MM EB MM EBC	30°, 37°, 38° 45°	2, 4 4	5-25 8-20	Ball Nose Milling	35 37	
MM EOB	—	4	8,10,12,16	Oval-Shaped (Barrel)	38	











E = Economical

Exchangeable Solid Carbide Heads









Type	Helix Angle	No. of Flutes	Diameter Range	Remarks	Page	
MM ELB	—	4	8,10,12,16	Lens-Shaped (Barrel)	37	
MM HCR MM HRF	—	2	8-16	Ball Nose for General Finishing	34	E 
MM HBR	—	2	10-25	Center Cutting, 240° Spherical Cutting Profile	34	E 
MM HT	—	2	10-20	Torodial	35	E 
MM FF	—	2	10-20	Feed Mill	30	E 
MM EFF	—	4,6	8-25.4	Feed Mill	31	
MM ETR	30°	6	8-16	Torodial	36	
MM HR MM ER	—	2 4	8-20 8-12.7	Corner Rounding	50 49	E 
MM HCD	—	2	8-20	Chamfering, Countersinking and Spot Drilling for DIN 74 Screw	46	E 
MM ECF	—	4, 6	10-25	Chamfering and Countersinking	47	
MM ECS	—	2	1.07-6.41	Centering Drills (DIN 332)	54	
MM ECDF	—	2	8-20	Flat Bottom Drill Heads	56	
MM HDF	—	2	9.8-15.7	Double Chamfering	47	
MM EDF	—	3	7.4-11.6	Double Chamfering	48	
MM TS	—	4,6	7.7-25	Groove Milling	48,61, 62	
MM GRIT-16K/P, 18K/P 3T6	—	3	15.7,17.7	Groove Milling	59	
MM GRIT-4T8	—	4	21.7,27.7	Groove Milling	60	
SD SP	—	8,10,12	31.7,31.25, 39.7,49.7	T-Slot	64	
MM SS	—	4	21.7	Involute Spline	63	

E = Economical







Exchangeable Solid Carbide Heads

Type	Helix Angle	No. of Flutes	Diameter Range	Remarks	Page	
MM GRIT-45A	—	3,4,6	17.7,21.7,27.7	45° Chamfering	48	
MM GRIT 28P-DR	—	6	—	Corner Round Milling	50	
MM TS-DG	—	4	15.5,18.5, 24.5		63	
MM TRF 55	—	5,6	11.94,15.94, 19.94	-	71	
MM TRF 60	—	5,6	11.94,15.94, 19.94,27.7	-	72	
SD TRD-M-SP	—	8,10	31.7,39.7	60° Partial Profile	73	
SD TRD-W-SP	—	8,10	31.7,39.7	55° Partial Profile	73	
MM TRD	—	3,4	15.7,21.7	55° / 60° Partial Profile	70-71	
MM ESR BLANKS MM ESR-1.5D BLANKS	—	—	8-32 8-25.4	Blank Heads	77	
MM TC-G	—	—	13.8,17.1,23.4, 28.6,35.6	Blank Heads	76	
DCN-MM		2	4-5.9	Modular SUMOCHAM Drill	57	







Indexable Endmills with a MULTI-MASTER Adaptation

Type	Helix Angle	No. of Flutes	Diameter Range	Remarks	Page	
T290 ELN-MM	—	2,3,4	10-16	—	25	
HP E90AN-MM	—	2,3,4,5	12,16,20	—	25	
T490 ELN-MM	—	2,3	16,20	—	25	
H490 E90AX-MM	—	3	20	—	26	
HM90 E90A-MM	—	2,3,4,5	16,20,25,32	—	26,28	
FF EWX-MM	—	2,3,4	16,20,25	—	33	
E90SO-MM	—	2,3,4,5,6	10-20	—	26	
HM390 ETP-MM	—	2,3,4	8-16	—	27	
HM390 ETC-MM	—	2,3,4	16,20,25	—	27	
HCE-MM	—	2	12,16,20	—	28	
E93CN-MM	—	2,3	16,20	—	39	
FFT3 EFM-MM	—	2-6	10-25	—	32	
FFX4 ED-MM	—	2,3,4	16,20,25	—	33	
H690 EWN-MM	—	3,5	20,25	—	29	
FFT3 EFM-MM	—	2-6	8-25	—	32	

Indexable Endmills with a MULTI-MASTER Adaptation

Type	Helix Angle	No. of Flutes	Diameter Range	Remarks	Page	
HCM-MM	—	2	12-25	—	45	
BCM-MM	—	2	12,16,20,25	—	45	
CH45-MM-PN06	—	1,2,3	11.7,16.7,18.7	—	51	
SGSF/A-MM	—	3,4,6	32,40	—	66	
TGSF-MM	—	5	50	—	66	
ETS-LN08-MM	—	4,6	32,40	—	66	
MTE-MM	—	1,2,3	13.7-30.4	—	74	

Shanks for MULTI-MASTER Adaptation

Type	Connection Thread Size (THSZMS)	Connection Diameter Machine Side (DCONMS)	Shank Size (SS)	Connection Thread Nominal Size Workpiece (THSZWS)	Page	
MM S-A (stepped shanks)	—	8-32	—	T04-T21	79	
MM S-A-N	—	10-16	—	T06-T10	81	
MM TS-A	—	8-16	—	T04-T10	81	
MM GRT (shanks)	—	9.52-12.7	—	T06-T08	81	
MM S-A (straight shanks)	—	12-40	—	T05-T21	82	
MM S-B (85° conical shanks)	—	8-40	—	T05-T15	82	

Shanks for MULTI-MASTER Adaptations

Type	Connection Thread Size (THSZMS)	Connection Diameter Machine Side (DCONMS)	Shank Size (SS)	Connection Thread Nominal Size Workpiece (THSZWS)	Page	
MM S-D (89° conical shanks)	-	12-32	-	T05-T15	83	
MM S-ER	-	-	ER11-ER32	T04-T12	84	
MM S-ER-H	-	-	ER32	T05-T15	84	
MM S-A-HSK	-	40-63	-	T05-T15	85	
MM S-A-SK	-	40	-	T06-T15	85	
MM S-A-C#	-	32-80	-	T05-T15	85	
MM CAB	M06-M12	9.7-21	-	T06-T08	86	
MM CAB-T-T-W	T06-T15	9.6-24	-	T05-T12	86	
SD CAB	T10-T15	15.2-23.9	-	M4x0.5 , M5x0.5 , M6x0.5	87	
MM CAB-T-T	T04-T21	-	-	T04-T21	86	

Accessories for MULTI-MASTER Heads

Type	Page	
MM Adjustable Torque Keys	11	

MULTI-MASTER and **FLEXFIT** Connection Options

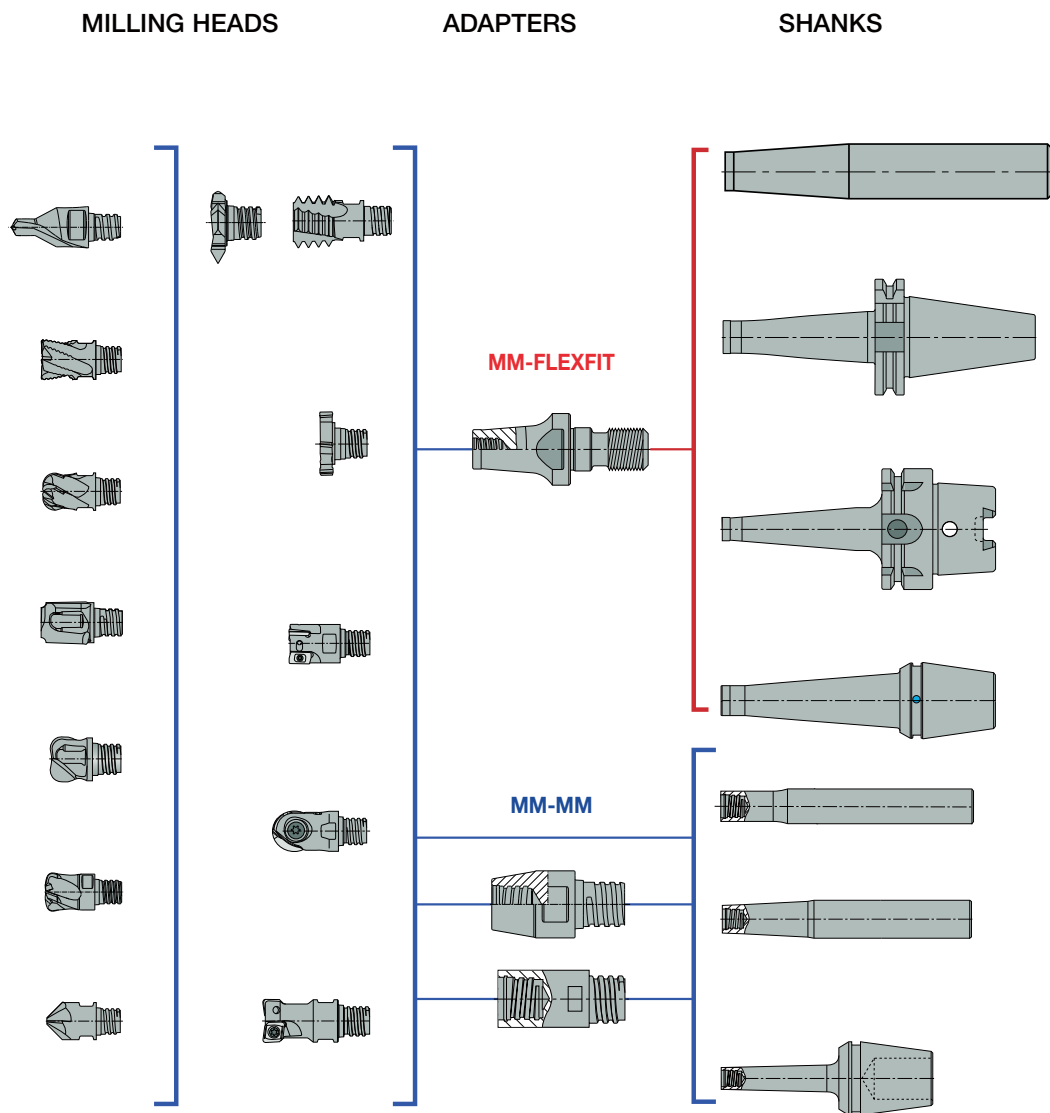

Features

Modular system reduces stock cost by using the same head with different shank options. Enables machining with larger overhang. Same head can be mounted on metric and inch combinations.



Clamping and Indexing Instructions

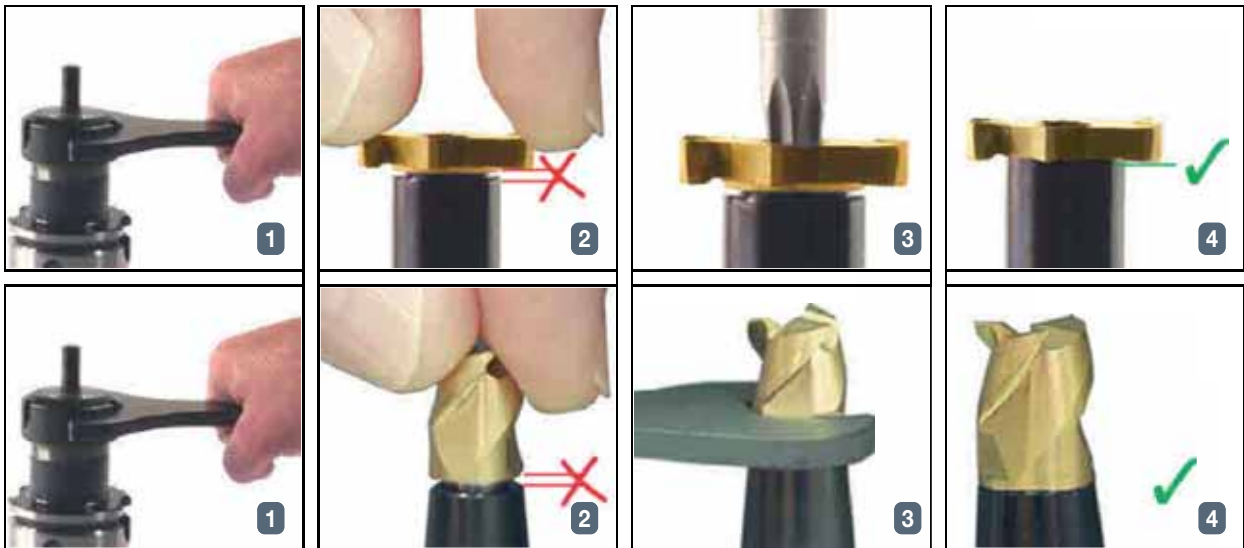

Do not apply lubricant to the threaded connection.

Thread Size	Key ⁽¹⁾	Tightening Torque (NxcM)
T04	MM KEY 6x4	400
T05	MM KEY 6x4	700
T06	MM KEY 8x5	1000
T08	MM KEY 10x7	1500
T10	MM KEY 13x8	2800
T12	MM KEY 16x9	2800
T15	MM KEY 20	4000
T21	MM WRENCH 24-21	11000

⁽¹⁾ Order separately



Accessories

MM Adjustable Torque Keys

Adjustable Torque Handle and Keys for Secure and Accurate Tightening of MULTI-MASTER Milling Heads

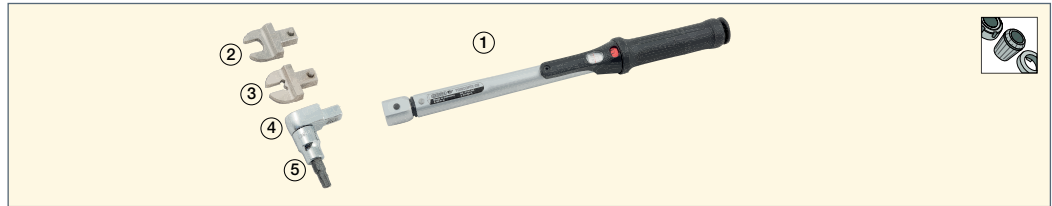

Designation	Fig.	Ts ⁽¹⁾	Key	TQ ⁽²⁾
TORQUE WRENCH 5-50Nm 9X12	1	-	-	-
MM WRENCH 6-05	2	T05	-	7.0
MM WRENCH 8-06	2	T06	-	10.0
MM WRENCH 10-08	2	T08	-	15.0
MM WRENCH 13-10	2	T10	-	28.0
MM WRENCH 16-12	2	T12	-	28.0
MM WRENCH 20-15	2	T15	-	40.0
MM WRENCH 4E-05	3	T05	-	7.0
MM WRENCH 5E-06	3	T06	-	10.0
MM WRENCH 7E-08	3	T08	-	15.0
MM WRENCH 8E-10	3	T10	-	28.0
MM WRENCH 9E-12	3	T12	-	28.0
INSERT TOOL 3/8" 9X12mm	4	-	-	-
BIT SOCKET T20 3/8" DRIVE	5	-	Torx T20	-
BIT SOCKET T25 3/8" DRIVE	5	-	Torx T25	-
BIT SOCKET T30 3/8" DRIVE	5	-	Torx T30	-
BIT SOCKET T40 3/8" DRIVE	5	-	Torx T40	-
BIT SOCKET T50 3/8" DRIVE	5	-	Torx T50	-

• NOTE: Recommended clamping torque for each MULTI-MASTER connection size, see page 10

⁽¹⁾ MULTI-MASTER connection size

⁽²⁾ Clamping torque Nxm

Adjustable Torque Handle with Interchangeable Wrenches for Clamping MULTI-MASTER Milling Heads



The adjustable torque handle, interchangeable wrenches and Torx bits are optional and should be ordered separately.

Table of Contents

Grade Priorities for **MULTI-MASTER Solid Carbide Heads**

Material Groups		ISO P	ISO M	ISO K	ISO N	ISO S	ISO H	
		1 - 11	12 - 13	14	15 - 20	21 - 28	31 - 37	38 - 41
		Steel	Stainless Steel Ferritic & Martensitic	Stainless Steel Austenitic & Duplex (Ferritic-Austenitic)	Cast Iron	Nonferrous	High Temp Alloys	Hard Steel & Hardened Cast Iron
MULTI-MASTER Endmills	Harder ↑			IC903				IC903
		IC903	IC903		IC903		IC903	
		IC608	IC608	IC608	IC608		IC908	IC608
		IC908	IC908	IC908	IC908			IC908
Roughing/ Semi-Finishing	↓ Tougher					IC08	IC08	
Coolant		N	Y	Y	N	Y	Y	N
MULTI-MASTER Endmills	Harder ↑			IC608			IC903	
		IC903	IC903		IC903		IC908	IC903
		IC608	IC608		IC608			IC608
		IC908	IC908	IC908	IC908			IC908
							IC08	
Finishing	Tougher ↓					IC08		
Coolant		N	Y	Y	N	Y	Y	N

■ First choice

Machining Data for MULTI-MASTER Exchangeable Solid Carbide Heads

ISO	Material	Condition	Tensile Strength [N/mm ²]	Hardness HB	Material Group No.	Cutting Speed (m/min)				
						IC900/IC608	IC903	IC300	IC08	
P	non-alloy steel and cast steel, free cutting steel	<0.25% C	annealed	420	125	1	260-280	260-280	210-220	180-200
		≥0.25% C	annealed	650	190	2	200-230	200-230	160-180	140-160
		<0.55% C	quenched and tempered	850	250	3	160-220	160-220	130-180	110-150
		annealed	750	220	4	160-220	160-220	130-180	110-150	
		quenched and tempered	1000	300	5	140-180	140-180	110-140	100-130	
	low alloy and cast steel (less than 5% of alloying elements)	annealed	600	200	6	160-220	160-220	130-180	110-150	
		quenched and tempered	930	275	7	120-180	120-180	100-140	80-130	
			1000	300	8	130-180	130-180	100-140	90-130	
			1200	350	9	140-180	140-180	110-140	100-130	
	high alloyed steel, cast steel and tool steel	annealed	680	200	10	130-180	130-180	100-140	90-130	
		quenched and tempered	1100	325	11	70-120	70-120	60-100	50-80	
stainless steel and cast steel	ferritic / martensitic	680	200	12	80-160	80-160	60-130	60-110		
	martensitic	820	240	13	60-150	60-150	50-120	40-100		
M	stainless steel and cast steel	austenitic, duplex	600	180	14	60-120	60-120	50-100	40-80	
K	gray cast iron (GG)	ferritic / pearlitic		180	15	80-260	80-250	60-210	60-180	
		pearlitic / martensitic		260	16	130-240	130-240	100-190	90-170	
	nodular cast iron (GGG)	ferritic		160	17	150-280	150-270	120-220	100-200	
		pearlitic		250	18	90-280	90-270	70-220	60-200	
	malleable cast iron	ferritic		130	19	150-280	150-270	120-220	100-200	
		pearlitic		230	20	140-240	140-240	110-190	100-170	
N	aluminum-wrought alloys	not hardenable		60	21				800-900	
		hardenable		100	22				700-800	
	aluminum-cast alloys	≤12% Si	not hardenable		75	23				800-900
		hardenable		90	24				750-850	
	>12% Si	high temperature		130	25				400-450	
		free cutting		110	26				500-550	
	copper alloys	brass		90	27				500-550	
		electrolytic copper		100	28				350-380	
non metallic	duroplastics, fiber plastics		70 Shore D	29						
	hard rubber		55 Shore D	30						
S	high temperature alloys	Fe based	annealed		200	31	20-40	20-40	20-30	10-20
			hardened		280	32	20-40	20-30	20-20	10-20
		Ni or Co based	annealed		250	33	20-50	20-30	20-20	20-50
			hardened		350	34	20-70	20-30	20-20	20-50
	titanium alloys	cast		320	35	30-70	30-80	20-60	20-50	
		pure	400	190	36	30-70	30-80	20-60	20-30	
	alpha+beta alloys, hardened	1050	310	37	30-70	30-80	20-60	20-30		
H	hardened steel	hardened		55 HRC	38	30-50	30-60	20-40	40-60	
		hardened		60 HRC	39	30-40	30-40	20-30	20-30	
	chilled cast iron	cast		400	40	60-80	70-90	50-60	65-75	
	cast iron	hardened		55 HRC	41	30-50	30-60	20-40	40-45	

MULTI-MASTER



Exchangeable Solid Carbide Heads

MULTI-MASTER
INDEXABLE SOLID CARBIDE LINE

MM FM
Interchangeable Solid Carbide
Face Milling Heads with
MULTI-MASTER Threaded
Connections

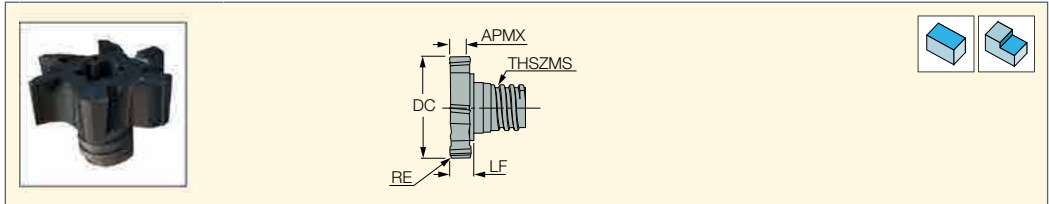

Designation	Dimensions							IC908	Recommended Machining Data
	DC	APMX	RE	NOF ⁽¹⁾	THSZMS	LF	∠		f _z (mm/t)
MM FM100-36R0.2-06T05	10.00	3.60	0.20	6	T05	4.40	T-20/3*	●	0.04-0.10
MM FM120-36R0.2-06T05	12.00	3.60	0.20	6	T05	4.40	T-20/3*	●	0.04-0.10
MM FM160-48R0.4-06T06	16.00	4.80	0.40	6	T06	5.60	T-25/3*	●	0.05-0.10
MM FM200-60R0.4-06T08	20.00	6.00	0.40	6	T08	6.80	T-40/3 L*	●	0.05-0.10
MM FM250-75R0.4-06T10	25.00	7.50	0.40	6	T10	8.40	T-50/3 L*	●	0.05-0.10

⁽¹⁾ Number of flutes
* Optional, to be ordered separately

MULTI-MASTER
INDEXABLE SOLID CARBIDE LINE

MM ECU
Interchangeable 3 Flute
Undersized Solid Carbide Heads
for Keyways (DIN 6885)

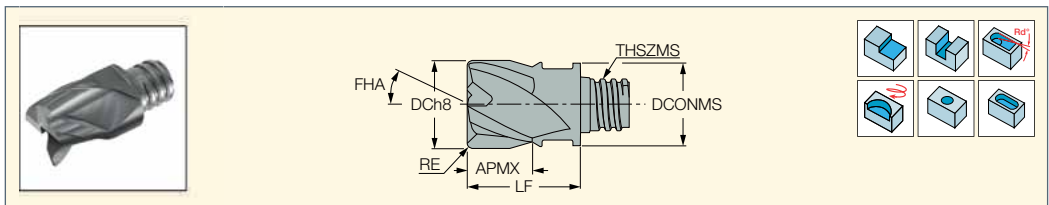

Designation	Dimensions								IC908	Recommended Machining Data
	DC	NOF ⁽¹⁾	APMX	RE	THSZMS	DCONMS	LF	FHA		f _z (mm/t)
MM ECU077E04R020-3T05	7.70	3	4.00	0.20	T05	7.70	10.00	38.0	●	0.03-0.08
MM ECU097E05R030-3T06	9.70	3	5.00	0.30	T06	9.60	13.00	38.0	●	0.03-0.09
MM ECU117E07R030-3T08	11.70	3	7.00	0.30	T08	11.50	16.50	38.0	●	0.03-0.10
MM ECU157E08R030-3T10	15.70	3	8.00	0.30	T10	15.30	20.50	38.0	●	0.04-0.12
MM ECU197E12R040-3T12	19.70	3	12.00	0.40	T12	18.45	25.50	38.0	●	0.05-0.13

• For shanks, see pages 79-86 • For clamping keys (to be ordered separately), tightening torques and clamping instructions, see pages 10-11
• Do not apply lubricant to the threaded connection. • For user guide, see pages 9,12-13

⁽¹⁾ Number of flutes

MULTI-MASTER
INDEXABLE SOLID CARBIDE LINE

MM EC-3
Interchangeable 3 Flute
Solid Carbide Endmill
Heads with 45° Helix

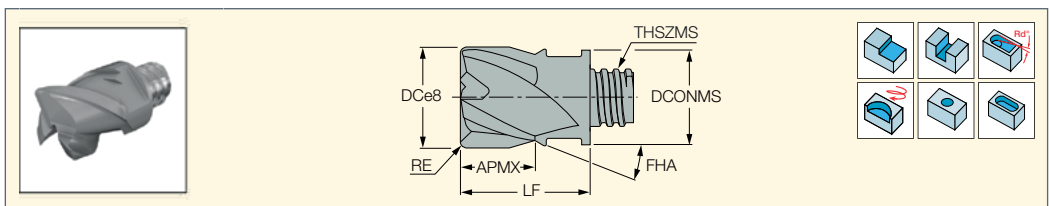

Designation	Dimensions								IC908	Recommended Machining Data
	DC	NOF ⁽²⁾	APMX	RE	THSZMS	LF	FHA	DCONMS		f _z (mm/t)
MM EC080B05R000-3T05	8.00	3	5.00	0.00	T05	10.00	45.0	7.70	●	0.03-0.09
MM EC100B07R000-3T06	10.00	3	7.00	0.00	T06	13.00	45.0	9.60	●	0.03-0.10
MM EC100B12R000-3T06	10.00	3	12.00	0.00	T06	19.00	45.0	9.60	●	0.03-0.10
MM EC120B09R000-3T08 ⁽¹⁾	12.00	3	9.00	0.00	T08	16.50	45.0	11.70	●	0.04-0.11
MM EC120B09R000-3T08	12.00	3	9.00	0.00	T08	16.50	45.0	11.70	●	0.04-0.11

• For shanks, see pages 79-86 • For clamping keys (to be ordered separately), tightening torques and clamping instructions, see pages 10-11
• Do not apply lubricant to the threaded connection. • For user guide, see pages 9,12-13

⁽¹⁾ With coolant holes directed to each flute

⁽²⁾ Number of flutes

MULTI-MASTER
INDEXABLE SOLID CARBIDE LINE

MM EC-4

Interchangeable 4 Flute Solid Carbide Endmill Heads with 30°, 45° Helix and Various Corner Radii



DC= 5.0 and 6.0

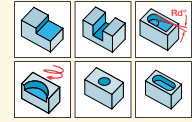
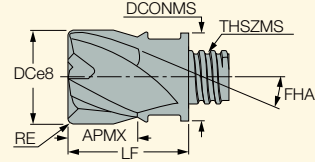
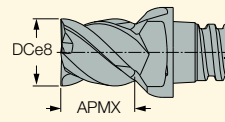

Designation	Dimensions									IC908	Recommended Machining Data
	DC	RE	FHA	NOF ⁽¹⁾	APMX	THSZMS	DCONMS	LF	f _z (mm/t)		
MM EC050B07R000-4T05	5.00	0.00	45.0	4	7.00	T05	8.00	15.00	●	0.02-0.06	
MM EC060B05R000-4T05	6.00	0.00	45.0	4	5.00	T05	8.00	10.00	●	0.03-0.07	
MM EC060B04R0.5-4T04	6.00	0.50	45.0	4	4.00	T04	5.80	8.50	●	0.02-0.04	
MM EC080B05R000-4T05	8.00	0.00	45.0	4	5.00	T05	7.70	10.00	●	0.03-0.09	
MM EC080B09R000-4T05	8.00	0.00	45.0	4	9.00	T05	7.70	15.00	●	0.03-0.09	
MM EC080A05R0.5-4T05	8.00	0.50	30.0	4	5.00	T05	7.70	10.00	●	0.03-0.09	
MM EC080A09R0.5-4T05	8.00	0.50	30.0	4	9.00	T05	7.70	15.00	●	0.03-0.09	
MM EC080B05R0.5-4T05	8.00	0.50	45.0	4	5.00	T05	7.70	10.00	●	0.03-0.09	
MM EC080A05R1.0-4T05	8.00	1.00	30.0	4	5.00	T05	7.70	10.00	●	0.03-0.09	
MM EC080B05R1.0-4T05	8.00	1.00	45.0	4	5.00	T05	7.70	10.00	●	0.03-0.09	
MM EC080A05R1.5-4T05	8.00	1.50	30.0	4	5.00	T05	7.70	10.00	●	0.03-0.09	
MM EC080B05R1.5-4T05	8.00	1.50	45.0	4	5.00	T05	7.70	10.00	●	0.03-0.09	
MM EC100B07R000-4T06	10.00	0.00	45.0	4	7.00	T06	9.60	13.00	●	0.03-0.10	
MM EC100B12R000-4T06	10.00	0.00	45.0	4	12.00	T06	9.60	19.00	●	0.03-0.10	
MM EC100A07R0.5-4T06	10.00	0.50	30.0	4	7.00	T06	9.60	13.00	●	0.03-0.10	
MM EC100B07R0.5-4T06	10.00	0.50	45.0	4	7.00	T06	9.60	13.00	●	0.03-0.10	
MM EC100A07R1.0-4T06	10.00	1.00	30.0	4	7.00	T06	9.60	13.00	●	0.03-0.10	
MM EC100B07R1.0-4T06	10.00	1.00	45.0	4	7.00	T06	9.60	13.00	●	0.03-0.10	
MM EC120B09R000-4T08	12.00	0.00	45.0	4	9.00	T08	11.70	16.50	●	0.04-0.11	
MM EC120B14R000-4T08	12.00	0.00	45.0	4	14.00	T08	11.70	23.00	●	0.04-0.11	
MM EC120A09R0.5-4T08	12.00	0.50	30.0	4	9.00	T08	11.70	16.50	●	0.04-0.11	
MM EC120B09R0.5-4T08	12.00	0.50	45.0	4	9.00	T08	11.70	16.50	●	0.04-0.11	
MM EC120A09R1.0-4T08	12.00	1.00	30.0	4	9.00	T08	11.70	16.50	●	0.04-0.11	
MM EC120B09R1.0-4T08	12.00	1.00	45.0	4	9.00	T08	11.70	16.50	●	0.04-0.11	
MM EC160B12R000-4T10	16.00	0.00	45.0	4	12.00	T10	15.30	20.50	●	0.05-0.13	
MM EC160A12R0.5-4T10	16.00	0.50	30.0	4	12.00	T10	15.30	20.50	●	0.05-0.13	
MM EC160B12R0.5-4T10	16.00	0.50	45.0	4	12.00	T10	15.30	20.50	●	0.05-0.13	
MM EC160A12R1.0-4T10	16.00	1.00	30.0	4	12.00	T10	15.30	20.50	●	0.05-0.13	
MM EC160B12R1.0-4T10	16.00	1.00	45.0	4	12.00	T10	15.30	20.50	●	0.05-0.13	
MM EC160A12R1.5-4T10	16.00	1.50	30.0	4	12.00	T10	15.30	20.50	●	0.05-0.13	
MM EC160B12R1.5-4T10	16.00	1.50	45.0	4	12.00	T10	15.30	20.50	●	0.05-0.13	
MM EC160A12R2.0-4T10	16.00	2.00	30.0	4	12.00	T10	15.30	20.50	●	0.05-0.13	
MM EC160B12R2.0-4T10	16.00	2.00	45.0	4	12.00	T10	15.30	20.50	●	0.05-0.13	
MM EC160A12R3.0-4T10	16.00	3.00	30.0	4	12.00	T10	15.30	20.50	●	0.05-0.13	
MM EC160B12R3.0-4T10	16.00	3.00	45.0	4	12.00	T10	15.30	20.50	●	0.05-0.13	
MM EC160A12R4.0-4T10	16.00	4.00	30.0	4	12.00	T10	15.30	20.50	●	0.05-0.13	
MM EC160B12R4.0-4T10	16.00	4.00	45.0	4	12.00	T10	15.30	20.50	●	0.05-0.13	
MM EC200B15R000-4T12	20.00	0.00	45.0	4	15.00	T12	18.45	25.50	●	0.05-0.13	
MM EC200A15R0.5-4T12	20.00	0.50	30.0	4	15.00	T12	18.45	25.50	●	0.05-0.13	
MM EC200A15R1.0-4T12	20.00	1.00	30.0	4	15.00	T12	18.45	25.50	●	0.05-0.13	
MM EC200A15R2.0-4T12	20.00	2.00	30.0	4	15.00	T12	18.45	25.50	●	0.05-0.13	
MM EC200A15R3.0-4T12	20.00	3.00	30.0	4	15.00	T12	18.45	25.50	●	0.05-0.13	

• For shanks, see pages 79-86 • For clamping keys (to be ordered separately), tightening torques and clamping instructions, see pages 10-11

• Do not apply lubricant to the threaded connection. • For user guide, see pages 9,12-13

⁽¹⁾ Number of flutes

MM EC-6

Interchangeable 6 Flute Solid Carbide Endmill Heads with 30°, 45° Helix and Various Corner Radii

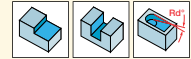
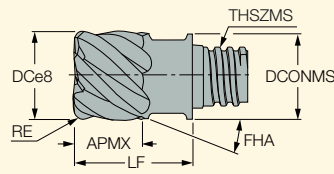

Designation	Dimensions										IC908	Recommended Machining Data f _z (mm/t)
	DC	NOF ⁽¹⁾	APMX	RE	THSZMS	DCONMS	LF	FHA	RMPX ⁽²⁾			
MM EC080A05R0.5-6T05	8.00	6	5.00	0.50	T05	7.70	10.00	30.0	6.0	●	0.03-0.09	
MM EC080A05R1.0-6T05	8.00	6	5.00	1.00	T05	7.70	10.00	30.0	6.0	●	0.03-0.09	
MM EC080A05R1.5-6T05	8.00	6	5.00	1.50	T05	7.70	10.00	30.0	6.0	●	0.03-0.09	
MM EC080B05R0.5-6T05	8.00	6	5.00	0.50	T05	7.70	10.00	45.0	3.0	●	0.03-0.10	
MM EC080B05R1.0-6T05	8.00	6	5.00	1.00	T05	7.70	10.00	45.0	3.0	●	0.03-0.09	
MM EC080B05R1.5-6T05	8.00	6	5.00	1.50	T05	7.70	10.00	45.0	3.0	●	0.03-0.09	
MM EC100A07R0.5-6T06	10.00	6	7.00	0.50	T06	9.60	13.00	30.0	6.0	●	0.03-0.10	
MM EC100A07R1.0-6T06	10.00	6	7.00	1.00	T06	9.60	13.00	30.0	6.0	●	0.03-0.10	
MM EC100A07R1.5-6T06	10.00	6	7.00	1.50	T06	9.60	13.00	30.0	6.0	●	0.03-0.10	
MM EC100B07R0.5-6T06	10.00	6	7.00	0.50	T06	9.60	13.00	45.0	3.0	●	0.04-0.10	
MM EC100B07R000-6T06	10.00	6	7.00	0.00	T06	9.60	13.00	45.0	3.0	●	0.03-0.10	
MM EC100B07R1.0-6T06	10.00	6	7.00	1.00	T06	9.60	13.00	45.0	3.0	●	0.04-0.10	
MM EC100B07R1.5-6T06	10.00	6	7.00	1.50	T06	9.60	13.00	45.0	3.0	●	0.03-0.10	
MM EC100B12R1.5-6T06	10.00	6	12.00	1.50	T06	9.60	19.00	45.0	3.0	●	0.04-0.10	
MM EC120A09R0.5-6T08	12.00	6	9.00	0.50	T08	11.70	16.50	30.0	6.0	●	0.04-0.11	
MM EC120A09R1.0-6T08	12.00	6	9.00	1.00	T08	11.70	16.50	30.0	6.0	●	0.04-0.11	
MM EC120B09R0.5-6T08	12.00	6	9.00	0.50	T08	11.70	16.50	45.0	3.0	●	0.04-0.10	
MM EC120B09R000-6T08	12.00	6	9.00	0.00	T08	11.70	16.50	45.0	3.0	●	0.04-0.11	
MM EC120B09R1.0-6T08	12.00	6	9.00	1.00	T08	11.70	16.50	45.0	3.0	●	0.04-0.10	
MM EC120B09R1.5-6T08	12.00	6	9.00	1.50	T08	11.70	16.50	45.0	3.0	●	0.04-0.11	

- For shanks, see pages 79-86
- For clamping keys (to be ordered separately), tightening torques and clamping instructions, see pages 10-11
- Do not apply lubricant to the threaded connection.
- For user guide, see pages 9,12-13

⁽¹⁾ Number of flutes

⁽²⁾ Maximum ramping angle

MM EC-D

Interchangeable 6, 8, 10 Flute Solid Carbide Endmill Heads with 50° Helix for Machining Hardened Steel

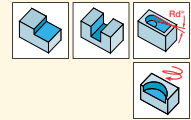
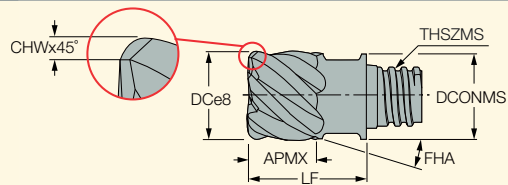

Designation	Dimensions										IC903	Recommended Machining Data f _z (mm/t)
	DC	NOF ⁽¹⁾	APMX	CHW	KCH	THSZMS	DCONMS	LF	FHA	RMPX ⁽²⁾		
MM EC080D05C01-6T05	8.00	6	5.00	0.10	45.0	T05	7.70	10.00	50.0	2.0	●	0.03-0.10
MM EC100D07C01-6T06	10.00	6	7.00	0.10	45.0	T06	9.60	13.00	50.0	2.0	●	0.03-0.10
MM EC120D09C01-6T08	12.00	6	9.00	0.10	45.0	T08	11.70	16.50	50.0	3.0	●	0.04-0.11
MM EC160D12C02-8T10	16.00	8	12.00	0.20	45.0	T10	15.30	20.50	50.0	3.0	●	0.05-0.13
MM EC200D15C02-10T12	20.00	10	15.00	0.20	45.0	T12	18.45	25.50	50.0	3.0	●	0.05-0.13

- For shanks, see pages 79-86
- For clamping keys (to be ordered separately), tightening torques and clamping instructions, see pages 10-11
- Do not apply lubricant to the threaded connection.
- For user guide, see pages 9,12-13

⁽¹⁾ Number of flutes

⁽²⁾ Maximum ramping angle

MULTI-MASTER
INDEXABLE SOLID CARBIDE LINE

MM EC-8/10

Interchangeable 8, 10 Flute Solid Carbide Endmill Heads with 30°, 45° Helix and Various Corner Radii

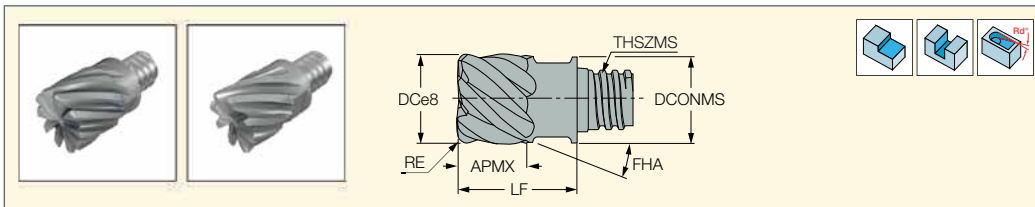

Designation	Dimensions										IC908	Recommended Machining Data f _z (mm/t)
	DC	NOF ⁽²⁾	APMX	RE	THSZMS	DCONMS	LF	FHA	RMPX ⁽³⁾			
MM EC160A12R0.5-8T10	16.00	8	12.00	0.50	T10	15.30	20.50	30.0	5.0	●	0.05-0.13	
MM EC160A12R0.5-8T10H ⁽¹⁾	16.00	8	12.00	0.50	T10	15.30	20.50	30.0	5.0	●	0.05-0.13	
MM EC160A12R1.0-8T10	16.00	8	12.00	1.00	T10	15.30	20.50	30.0	5.0	●	0.05-0.13	
MM EC160A12R1.6-8T10	16.00	8	12.00	1.60	T10	15.30	20.50	30.0	5.0	●	0.05-0.13	
MM EC160A12R2.0-8T10	16.00	8	12.00	2.00	T10	15.30	20.50	30.0	5.0	●	0.05-0.13	
MM EC160B12R0.5-8T10	16.00	8	12.00	0.50	T10	15.30	20.50	45.0	5.0	●	0.05-0.13	
MM EC160B12R1.0-8T10	16.00	8	12.00	1.00	T10	15.30	20.50	45.0	5.0	●	0.05-0.13	
MM EC160B12R1.6-8T10	16.00	8	12.00	1.60	T10	15.30	20.50	45.0	5.0	●	0.05-0.13	
MM EC160B12R2.0-8T10	16.00	8	12.00	2.00	T10	15.30	20.50	45.0	5.0	●	0.05-0.13	
MM EC200A15R1.0-10T12	20.00	10	15.00	1.00	T12	18.45	25.50	30.0	3.0	●	0.05-0.13	
MM EC200A15R2.0-10T12	20.00	10	15.00	2.00	T12	18.45	25.50	30.0	3.0	●	0.05-0.13	
MM EC250A22R0.8-10T15	25.00	10	22.00	0.80	T15	23.90	37.00	30.0	3.0	●	0.05-0.13	

- For shanks, see pages 79-86
- For clamping keys (to be ordered separately), tightening torques and clamping instructions, see pages 10-11
- Do not apply lubricant to the threaded connection.
- For user guide, see pages 9,12-13

⁽¹⁾ With a central coolant hole
⁽²⁾ Number of flutes
⁽³⁾ Maximum ramping angle

MULTI-MASTER
INDEXABLE SOLID CARBIDE LINE
CHATTERFREE
MULTI-MASTER LINE

MM EC-CF

Interchangeable Solid Carbide Endmill Heads for CHATTERFREE Roughing and Finishing Operations

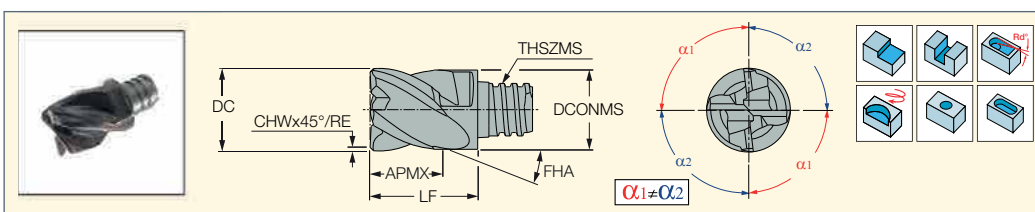

Designation	Dimensions											IC908	Recommended Machining Data f _z (mm/t)
	DC	RE	NOF ⁽²⁾	APMX	THSZMS	DCONMS	LF	FHA	CHW	KCH			
MM EC080E05C3CF-4T05	8.00	-	4	5.00	T05	7.70	10.00	38.0	0.30	45.0	●	0.03-0.09	
MM EC080E05R0CF-4T05	8.00	-	4	5.00	T05	7.70	10.00	38.0	-	-	●	0.03-0.09	
MM EC080E05R05CF-4T05	8.00	0.50	4	5.00	T05	7.70	10.00	38.0	-	-	●	0.03-0.09	
MM EC100E07C4CF-4T06	10.00	-	4	7.00	T06	9.60	13.00	38.0	0.40	45.0	●	0.03-0.10	
MM EC100E07R00CF-4T06	10.00	-	4	7.00	T06	9.60	13.00	38.0	-	-	●	0.03-0.10	
MM EC100E07R02CF-4T06	10.00	0.20	4	7.00	T06	9.60	13.00	38.0	-	-	●	0.03-0.10	
MM EC100E07R04CF-4T06	10.00	0.40	4	7.00	T06	9.60	13.00	38.0	-	-	●	0.03-0.10	
MM EC100E07R05CF-4T06	10.00	0.50	4	7.00	T06	9.60	13.00	38.0	-	-	●	0.03-0.10	
MM EC100E07R25CF-4T06	10.00	2.50	4	7.00	T06	9.60	13.00	38.0	-	-	●	0.03-0.10	
MM EC120E09C5CF-4T08	12.00	-	4	9.00	T08	11.70	16.50	38.0	0.50	45.0	●	0.04-0.11	
MM EC120E09C5CF-4T08I ⁽¹⁾	12.00	-	4	9.00	T08	11.70	16.50	38.0	0.50	45.0	●	0.04-0.11	
MM EC120E09R00CF-4T08	12.00	-	4	9.00	T08	11.70	16.50	38.0	-	-	●	0.04-0.11	
MM EC120E09R02CF-4T08	12.00	0.20	4	9.00	T08	11.70	16.50	38.0	-	-	●	0.04-0.11	
MM EC120E09R04CF-4T08	12.00	0.40	4	9.00	T08	11.70	16.50	38.0	-	-	●	0.04-0.11	
MM EC120E09R05CF-4T08	12.00	0.50	4	9.00	T08	11.70	16.50	38.0	-	-	●	0.04-0.11	
MM EC120E09R15CF-4T08	12.00	1.50	4	9.00	T08	11.70	16.50	38.0	-	-	●	0.04-0.11	
MM EC160E12C6CF-4T10	16.00	-	4	12.00	T10	15.30	20.50	38.0	0.60	45.0	●	0.05-0.13	
MM EC160E12R05CF-4T10	16.00	0.50	4	12.00	T10	15.30	20.50	38.0	-	-	●	0.05-0.13	
MM EC200E15C6CF-4T12	20.00	-	4	15.00	T12	18.45	25.50	38.0	0.60	45.0	●	0.05-0.17	
MM EC200E15R05CF-4T12	20.00	0.50	4	15.00	T12	18.45	25.50	38.0	-	-	●	0.05-0.17	
MM EC250E28C6CF-12T15	25.00	-	12	28.00	T15	23.90	43.00	38.0	0.60	45.0	●	0.06-0.13	
MM EC250E28C6CF-4T15	25.00	-	4	28.00	T15	23.90	43.00	38.0	0.60	45.0	●	0.06-0.17	
MM EC250E22C6CF-4T15	25.00	-	4	22.00	T15	23.90	37.00	38.0	0.60	45.0	●	0.06-0.17	
MM EC250E22R05CF-4T15	25.00	0.50	4	22.00	T15	23.90	37.00	38.0	-	-	●	0.06-0.17	
MM EC250E22R10CF-4T15	25.00	1.00	4	22.00	T15	23.90	37.00	38.0	-	-	●	0.06-0.17	
MM EC250E22R20CF-4T15	25.00	2.00	4	22.00	T15	23.90	37.00	38.0	-	-	●	0.06-0.17	
MM EC250E22R30CF-4T15	25.00	3.00	4	22.00	T15	23.90	37.00	38.0	-	-	●	0.06-0.17	
MM EC320H38C06-4T21	32.00	-	4	38.00	T21	30.00	55.00	38.0	0.60	45.0	●	0.06-0.18	

- For shanks, see pages 79-86
- For clamping keys (to be ordered separately), tightening torques and clamping instructions, see pages 10-11
- Do not apply lubricant to the threaded connection.
- For user guide, see pages 9,12-13

⁽¹⁾ With coolant holes directed to each flute
⁽²⁾ Number of flutes

MM EC-H-4-CF

Interchangeable Carbide Endmill Heads for CHATTERFREE Milling Alloyed Steel

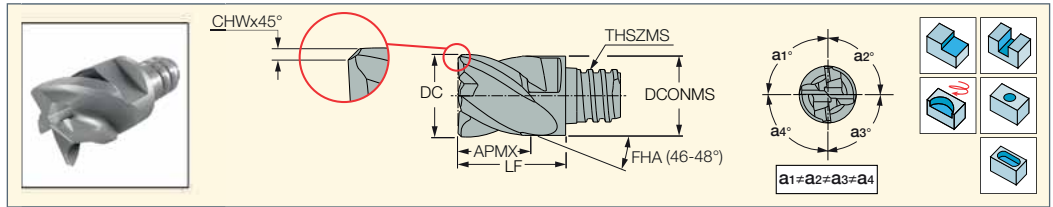

Designation	Dimensions								IC908	Recommended Machining Data
	DC	NOF ⁽¹⁾	APMX	THSZMS	DCONMS	LF	CHW	KCH		f _z (mm/t)
MM EC080H05C3-4T05CF	8.00	4	5.00	T05	7.70	10.00	0.30	45.0	●	0.03-0.09
MM EC100H07C4-4T06CF	10.00	4	7.00	T06	9.60	13.00	0.40	45.0	●	0.03-0.10
MM EC120H09C5-4T08CF	12.00	4	9.00	T08	11.70	16.50	0.50	45.0	●	0.04-0.11
MM EC160H12C6-4T10CF	16.00	4	12.00	T10	15.30	20.50	0.60	45.0	●	0.05-0.13
MM EC200H15C6-4T12CF	20.00	4	15.00	T12	18.45	25.50	0.60	45.0	●	0.05-0.17

- For shanks, see pages 79-86 • For clamping keys (to be ordered separately), tightening torques and clamping instructions, see pages 10-11
- Do not apply lubricant to the threaded connection. • For user guide, see pages 9,12-13

⁽¹⁾ Number of flutes

MM EC-H-5-CF

Interchangeable Carbide Endmill Heads for CHATTERFREE Milling of High Temperature Alloys such as titanium and inconel

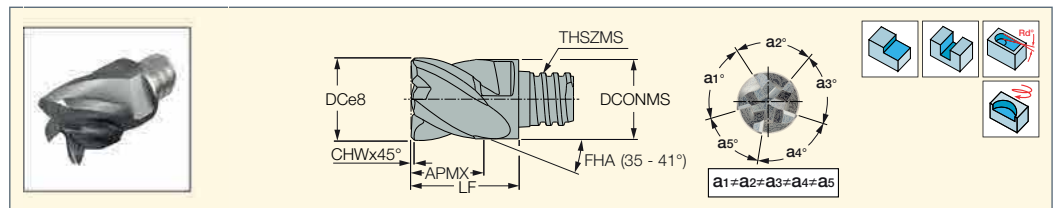

Designation	Dimensions									IC908	Recommended Machining Data
	DC	NOF ⁽¹⁾	APMX	THSZMS	DCONMS	LF	RMPX ⁽²⁾	CHW	KCH		f _z (mm/t)
MM EC080H05C3-5T05CF	8.00	5	5.00	T05	7.70	10.00	5.0	0.30	45.0	●	0.03-0.09
MM EC100H07C4-5T06CF	10.00	5	7.00	T06	9.60	13.00	5.0	0.40	45.0	●	0.03-0.10
MM EC120H09C5-5T08CF	12.00	5	9.00	T08	11.70	16.50	4.0	0.50	45.0	●	0.04-0.11
MM EC160H12C6-5T10CF	16.00	5	12.00	T10	15.30	20.50	4.0	0.60	45.0	●	0.05-0.13
MM EC200H15C6-5T12CF	20.00	5	15.00	T12	18.45	25.50	3.0	0.60	45.0	●	0.05-0.17
MM EC250H22C6-5T15CF	25.00	5	22.00	T15	23.90	37.00	3.0	0.60	45.0	●	0.06-0.17

- For shanks, see pages 79-86 • For clamping keys (to be ordered separately), tightening torques and clamping instructions, see pages 10-11
- Do not apply lubricant to the threaded connection. • For user guide, see pages 9,12-13

⁽¹⁾ Number of flutes

⁽²⁾ Maximum ramping angle

FINISHED
MULTI-MASTER LINE

MM EFS

Combination of Interchangeable Solid Carbide Endmill Heads for Roughing and Finishing

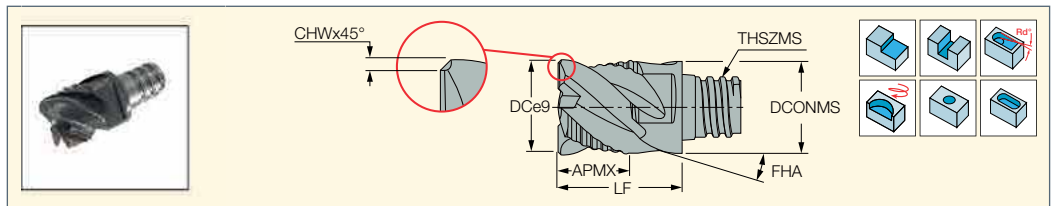

Designation	Dimensions									IC908	Recommended Machining Data
	DC	NOF ⁽¹⁾	APMX	THSZMS	DCONMS	LF	FHA	CHW	KCH		f _z (mm/t)
MM EFS080B05-4T05	8.00	4	5.00	T05	7.70	10.00	45.0	0.30	45.0	●	0.03-0.08
MM EFS100B07-4T06	10.00	4	7.00	T06	9.60	13.00	45.0	0.30	45.0	●	0.03-0.09
MM EFS120B09-4T08	12.00	4	9.00	T08	11.70	16.50	45.0	0.40	45.0	●	0.04-0.10
MM EFS160B12-4T10	16.00	4	12.00	T10	15.30	20.50	45.0	0.60	45.0	●	0.05-0.11
MM EFS200B15-4T12	20.00	4	15.00	T12	18.45	25.50	45.0	0.60	45.0	●	0.05-0.11
MM EFS250B22-4T15	25.00	4	22.00	T15	23.90	37.00	45.0	0.60	45.0	●	0.06-0.11

- For shanks, see pages 79-86 • For clamping keys (to be ordered separately), tightening torques and clamping instructions, see pages 10-11
- Do not apply lubricant to the threaded connection. • For user guide, see pages 9,12-13

⁽¹⁾ Number of flutes

FINISHED
MULTI-MASTER LINE
CHATTERFREE
MULTI-MASTER LINE

MM EFS-CF

4 Flute Solid Carbide Heads with 38° Helix and Variable Pitch for CHATTERFREE Roughing and Finishing Applications

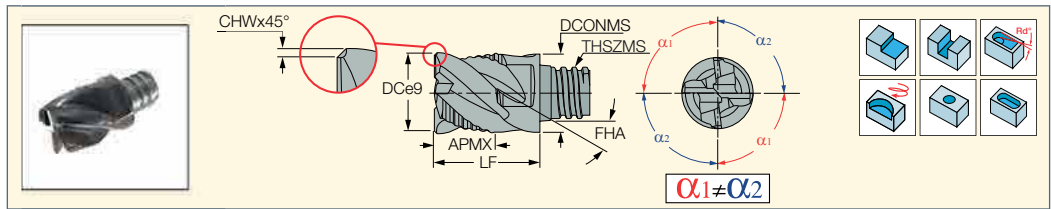

Designation	Dimensions									IC908	Recommended Machining Data
	DC	NOF ⁽¹⁾	APMX	CHW	KCH	THSZMS	DCONMS	LF	FHA		f _z (mm/t)
MM EFS060E05-4T05 CF	6.00	4	5.00	0.25	45.0	T05	7.70	10.00	38.0	●	0.03-0.08
MM EFS080E05-4T05 CF	8.00	4	5.00	0.30	45.0	T05	7.70	10.00	38.0	●	0.03-0.08
MM EFS100E07-4T06 CF	10.00	4	7.00	0.40	45.0	T06	9.60	13.00	38.0	●	0.03-0.09
MM EFS120E09-4T08 CF	12.00	4	9.00	0.50	45.0	T08	11.70	16.50	38.0	●	0.04-0.10
MM EFS160E12-4T10 CF	16.00	4	12.00	0.60	45.0	T10	15.30	20.50	38.0	●	0.05-0.11
MM EFS200E15-4T12 CF	20.00	4	16.00	0.60	45.0	T12	18.45	25.50	38.0	●	0.05-0.11
MM EFS250E22-4T15 CF	25.00	4	22.00	0.60	45.0	T15	23.90	37.00	38.0	●	0.06-0.11

- For shanks, see pages 79-86
- For clamping keys (to be ordered separately), tightening torques and clamping instructions, see pages 10-11
- Do not apply lubricant to the threaded connection.
- For user guide, see pages 9,12-13

⁽¹⁾ Number of flutes

MULTI-MASTER
INDEXABLE SOLID CARBIDE LINE

MM ERS

Interchangeable Solid Carbide Rough Milling Heads for High Metal Removal Rates

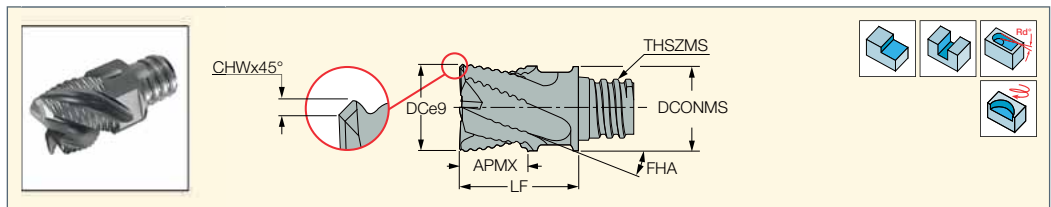

Designation	Dimensions										IC908	Recommended Machining Data
	DC	NOF ⁽³⁾	APMX	THSZMS	DCONMS	LF	FHA	RMPX ⁽⁴⁾	CHW	KCH		f _z (mm/t)
MM ERS080B05-4T05	8.00	4	5.00	T05	7.70	10.00	45.0	5.0	0.25	45.0	●	0.03-0.08
MM ERS080B09-4T05	8.00	4	9.00	T05	7.70	15.00	45.0	5.0	0.25	45.0	●	0.03-0.08
MM ERS100B07-4T06	10.00	4	7.00	T06	9.60	13.00	45.0	5.0	0.30	45.0	●	0.03-0.09
MM ERS120B09-4T08	12.00	4	9.00	T08	11.70	16.50	45.0	5.0	0.35	45.0	●	0.04-0.10
MM ERS120B09-4T08H ⁽¹⁾	12.00	4	9.00	T08	11.70	16.50	45.0	5.0	0.35	45.0	●	0.04-0.10
MM ERS120B09-4T08I ⁽²⁾	12.00	4	9.00	T08	11.70	16.50	45.0	5.0	0.35	45.0	●	0.04-0.11
MM ERS120B14-4T08	12.00	4	14.00	T08	11.70	23.00	45.0	5.0	0.35	45.0	●	0.04-0.10
MM ERS160B12-5T10	16.00	5	12.00	T10	15.30	20.50	45.0	5.0	0.40	45.0	●	0.04-0.10
MM ERS160B12-5T10H ⁽¹⁾	16.00	5	12.00	T10	15.30	20.50	45.0	5.0	0.40	45.0	●	0.04-0.10
MM ERS200B15-6T12	20.00	6	15.00	T12	18.45	25.50	45.0	3.0	0.40	45.0	●	0.05-0.11
MM ERS250B22-6T15	25.00	6	22.00	T15	23.90	37.00	45.0	3.0	0.50	45.0	●	0.05-0.11

- For shanks, see pages 79-86
- For clamping keys (to be ordered separately), tightening torques and clamping instructions, see pages 10-11
- Do not apply lubricant to the threaded connection.
- For user guide, see pages 9,12-13

⁽¹⁾ With a central coolant hole

⁽²⁾ With coolant holes directed to each flute

⁽³⁾ Number of flutes

⁽⁴⁾ Maximum ramping angle

MM ERA

Interchangeable Solid Carbide
Rough Milling Heads for
Machining Aluminum at High
Metal Removal Rates

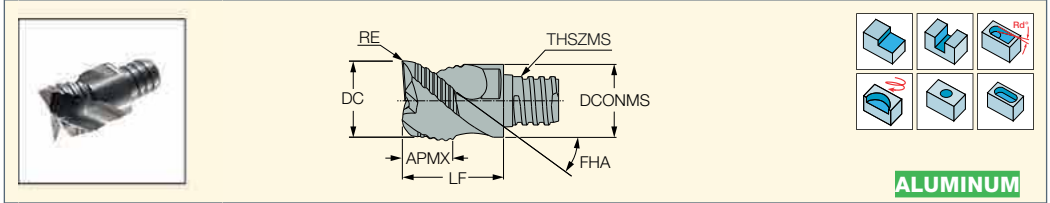

Designation	Dimensions									Recommended Machining Data	
	DC	NOF ⁽¹⁾	APMX	RE	THSZMS	DCONMS	LF	FHA	IC08	f _z (mm/t)	
MM ERA080B05R0.2-3T05	8.00	3	5.00	0.20	T05	7.70	10.00	45.0	●	0.03-0.15	
MM ERA100B06R0.2-3T06	10.00	3	6.00	0.20	T06	9.60	13.00	45.0	●	0.05-0.20	
MM ERA120B08R0.2-3T08	12.00	3	8.00	0.20	T08	11.70	16.50	45.0	●	0.07-0.22	
MM ERA160B10R0.2-3T10	16.00	3	10.00	0.20	T10	15.30	20.50	45.0	●	0.07-0.25	
MM ERA200B12R0.2-3T12	20.00	3	12.00	0.20	T12	18.45	25.50	45.0	●	0.07-0.25	
MM ERA250B19R0.2-3T15	25.00	3	19.00	0.20	T15	23.90	37.00	45.0	●	0.07-0.25	

- For shanks, see pages 79-86
 - For clamping keys (to be ordered separately), tightening torques and clamping instructions, see pages 10-11
 - Do not apply lubricant to the threaded connection.
 - For user guide, see pages 9,12-13
- ⁽¹⁾ Number of flutes

MM EA

Interchangeable Solid Carbide
Slot Drill Milling Heads for
Machining Aluminum

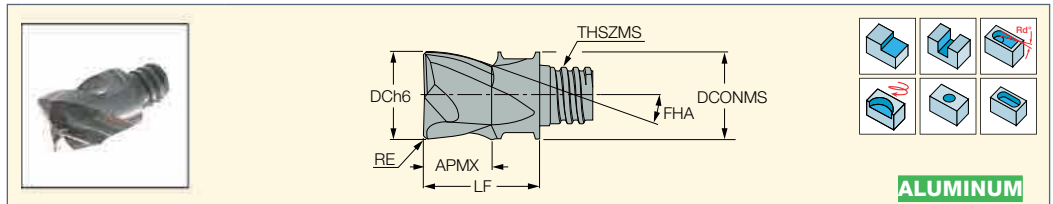

Designation	Dimensions									Recommended Machining Data	
	DC	NOF ⁽¹⁾	APMX	RE	THSZMS	DCONMS	LF	FHA	IC08	f _z (mm/t)	
MM EA060B03R0.0-3T04	6.00	3	3.20	0.00	T04	5.80	8.50	45.0	●	0.02-0.05	
MM EA080B05R0.5-2T05	8.00	2	5.00	0.50	T05	7.70	10.00	45.0	●	0.03-0.09	
MM EA080B05R0.5-3T05	8.00	3	5.00	0.50	T05	7.70	10.00	45.0	●	0.03-0.09	
MM EA100B07R0.5-2T06	10.00	2	7.00	0.50	T06	9.60	13.00	45.0	●	0.03-0.10	
MM EA100B07R1.0-2T06	10.00	2	7.00	1.00	T06	9.60	13.00	45.0	●	0.03-0.10	
MM EA100B06R0.5-3T06	10.00	3	6.00	0.50	T06	9.60	13.00	45.0	●	0.03-0.10	
MM EA100B06R1.0-3T06	10.00	3	6.00	1.00	T06	9.60	13.00	45.0	●	0.03-0.10	
MM EA120B09R0.5-2T08	12.00	2	9.00	0.50	T08	11.70	16.50	45.0	●	0.04-0.11	
MM EA120B09R1.0-2T08	12.00	2	9.00	1.00	T08	11.70	16.50	45.0	●	0.04-0.11	
MM EA120B08R0.5-3T08	12.00	3	8.00	0.50	T08	11.70	16.50	45.0	●	0.04-0.11	
MM EA120B08R1.0-3T08	12.00	3	8.00	1.00	T08	11.70	16.50	45.0	●	0.04-0.11	
MM EA120B08R3.0-3T08	12.00	3	8.00	3.00	T08	11.70	16.50	45.0	●	0.04-0.11	
MM EA160B10R000-3T10	16.00	3	10.00	0.00	T10	15.30	20.50	45.0	●	0.05-0.13	
MM EA160B10R1.0-3T10	16.00	3	10.00	1.00	T10	15.30	20.50	45.0	●	0.05-0.13	
MM EA160B10R2.0-3T10	16.00	3	10.00	2.00	T10	15.30	20.50	45.0	●	0.05-0.13	
MM EA160B10R3.0-3T10	16.00	3	10.00	3.00	T10	15.30	20.50	45.0	●	0.05-0.13	
MM EA160B10R4.0-3T10	16.00	3	10.00	4.00	T10	15.30	20.50	45.0	●	0.05-0.13	
MM EA200B12R0.5-3T12	20.00	3	12.00	0.50	T12	18.45	25.50	45.0	●	0.05-0.13	
MM EA200B12R1.0-3T12	20.00	3	12.00	1.00	T12	18.45	25.50	45.0	●	0.05-0.13	
MM EA200B12R2.0-3T12	20.00	3	12.00	2.00	T12	18.45	25.50	45.0	●	0.05-0.13	
MM EA200B12R3.0-3T12	20.00	3	12.00	3.00	T12	18.45	25.50	45.0	●	0.05-0.13	
MM EA200B12R4.0-3T12	20.00	3	12.00	4.00	T12	18.45	25.50	45.0	●	0.05-0.13	

- For shanks, see pages 79-86
 - For clamping keys (to be ordered separately), tightening torques and clamping instructions, see pages 10-11
 - Do not apply lubricant to the threaded connection.
- ⁽¹⁾ Number of flutes

CHATTERFREE
MULTI-MASTER LINE

MM EA-CF

Interchangeable Solid Carbide Endmill Heads with Different Helix for Machining Aluminum

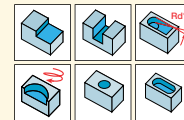
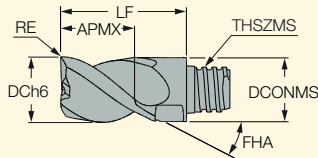

ALUMINUM

Designation	Dimensions								IC08	Recommended Machining Data
	DC	NOF ⁽¹⁾	APMX	RE	THSZMS	DCONMS	LF	FHA		f _z (mm/t)
MM EA080H08R0CF-4T05	8.00	4	8.00	0.00	T05	7.70	15.00	40.0	●	0.03-0.09
MM EA100H10R0CF-4T06	10.00	4	10.00	0.00	T06	9.60	19.00	40.0	●	0.03-0.10
MM EA120H12R0.2CF-3T08	12.00	3	12.00	0.20	T08	11.70	23.00	40.0	●	0.04-0.11
MM EA120H12R0CF-4T08	12.00	4	12.00	0.00	T08	11.70	23.00	40.0	●	0.04-0.11
MM EA160H16R0.0CF-3T10	16.00	3	16.00	0.00	T10	15.30	28.00	40.0	●	0.05-0.13
MM EA160H16R0.2CF-3T10	16.00	3	16.00	0.20	T10	15.30	28.00	40.0	●	0.05-0.13
MM EA160H16R0.5CF-3T10	16.00	3	16.00	0.50	T10	15.30	28.00	40.0	●	0.05-0.13
MM EA160H16R2.5CF-3T10	16.00	3	16.00	2.50	T10	15.30	28.00	40.0	●	0.05-0.13
MM EA160H16R0CF-4T10	16.00	4	16.00	0.00	T10	15.30	26.00	40.0	●	0.05-0.12
MM EA200H20R0.0CF-3T12	20.00	3	20.00	0.00	T12	18.45	34.00	40.0	●	0.05-0.13
MM EA200H20R0.2CF-3T12	20.00	3	20.00	0.20	T12	18.45	34.00	40.0	●	0.05-0.13
MM EA200H20R0.5CF-3T12	20.00	3	20.00	0.50	T12	18.45	34.00	40.0	●	0.05-0.13
MM EA200H20R2.5CF-3T12	20.00	3	20.00	2.50	T12	18.45	34.00	40.0	●	0.05-0.13
MM EA250H19R0.5-3T15	25.00	3	19.00	0.50	T15	23.90	37.00	40.0	●	0.06-0.16
MM EA250H19R1.0-3T15	25.00	3	19.00	1.00	T15	23.90	37.00	40.0	●	0.06-0.16
MM EA250H19R3.0-3T15	25.00	3	19.00	3.00	T15	23.90	37.00	40.0	●	0.06-0.16

- For shanks, see pages 79-86
- For clamping keys (to be ordered separately), tightening torques and clamping instructions, see pages 10-11
- Do not apply lubricant to the threaded connection.
- For user guide, see pages 9,12-13

⁽¹⁾ Number of flutes

MULTI-MASTER
INDEXABLE SOLID CARBIDE LINE

MM ERS-1.5xD

Interchangeable Solid Carbide Rough Milling Heads with 1.5xD Flute Lengths for High Metal Removal Rates

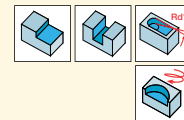
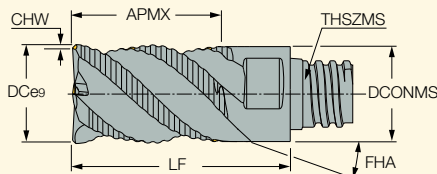

Designation	Dimensions										IC908	Recommended Machining Data
	DC	NOF ⁽¹⁾	APMX	CHW	KCH	THSZMS	DCONMS	LF	FHA	RMPX ⁽²⁾		f _z (mm/t)
MM ERS080B12-4T05	8.00	4	12.00	0.25	45.0	T05	7.70	18.00	46.0	5.0	●	0.03-0.08
MM ERS100B15-4T06	10.00	4	15.00	0.30	45.0	T06	9.60	22.00	46.0	5.0	●	0.03-0.09
MM ERS120B18-4T08	12.00	4	18.00	0.35	45.0	T08	11.70	27.00	46.0	5.0	●	0.04-0.10
MM ERS160B24-5T10	16.00	5	24.00	0.40	45.0	T10	15.30	33.50	40.0	5.0	●	0.04-0.10
MM ERS200B30-6T12	20.00	6	30.00	0.40	45.0	T12	18.45	41.00	47.0	3.0	●	0.05-0.11
MM ERS250B37-6T15	25.00	6	37.00	0.50	45.0	T15	23.90	52.50	47.0	3.0	●	0.05-0.11

- For shanks, see pages 79-86
- For clamping keys (to be ordered separately), tightening torques and clamping instructions, see pages 10-11
- Do not apply lubricant to the threaded connection
- For user guide, see pages 9,12-13

⁽¹⁾ Number of flutes

⁽²⁾ Maximum ramping angle

MM EC-Z4-1.5xD
Interchangeable Solid Carbide Endmill Heads with 1.5xD Flute Lengths for Roughing and Finishing

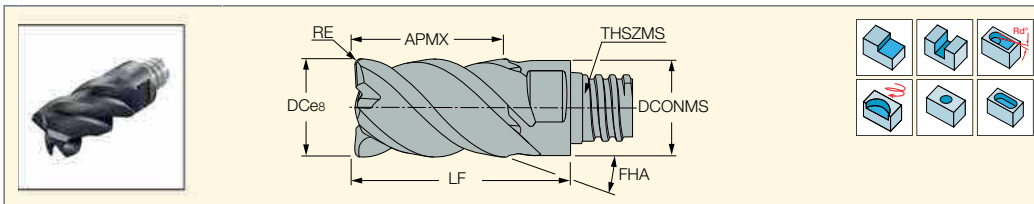

Designation	Dimensions								Tough ↔ Hard		Recommended Machining Data f _z (mm/t)
	DC	NOF ⁽¹⁾	APMX	RE	THSZMS	DCONMS	LF	FHA	IC908	IC608	
MM EC080B12R000-4T05	8.00	4	12.00	0.00	T05	7.70	18.00	46.5		●	0.03-0.09
MM EC080H12R05CF-4T05	8.00	4	12.00	0.50	T05	7.70	18.00	46.5	●		0.03-0.09
MM EC100B15R000-4T06	10.00	4	15.00	0.00	T06	9.60	22.00	46.5		●	0.03-0.10
MM EC100H15R05CF-4T06	10.00	4	15.00	0.50	T06	9.60	22.00	46.5	●		0.03-0.10
MM EC120B18R000-4T08	12.00	4	18.00	0.00	T08	11.70	27.00	46.5		●	0.04-0.11
MM EC120H18R05CF-4T08	12.00	4	18.00	0.50	T08	11.70	27.00	46.5	●		0.04-0.11
MM EC160B24R000-4T10	16.00	4	24.00	0.00	T10	15.30	33.50	46.5		●	0.05-0.13
MM EC160H24R05CF-4T10	16.00	4	24.00	0.50	T10	15.30	33.50	46.5	●		0.05-0.13
MM EC200B30R000-4T12	20.00	4	30.00	0.00	T12	18.45	41.00	46.5		●	0.05-0.17
MM EC200H30R05CF-4T12	20.00	4	30.00	0.50	T12	18.45	41.00	46.5	●		0.05-0.17
MM EC250B37R000-4T15	25.00	4	37.00	0.00	T15	23.90	52.50	46.5		●	0.06-0.17
MM EC250H37R05CF-4T15	25.00	4	37.00	0.50	T15	23.90	52.50	46.5	●		0.06-0.17

• For shanks, see pages 79-86 • Do not apply lubricant to the threaded connection • For user guide, see pages 9,12-13

⁽¹⁾ Number of flutes

MM EC-CF-Z7/9-1.5xD
Interchangeable 7, 9 Flute Solid Carbide Endmill Heads with 36° Helix and 1.5xD Flute Lengths

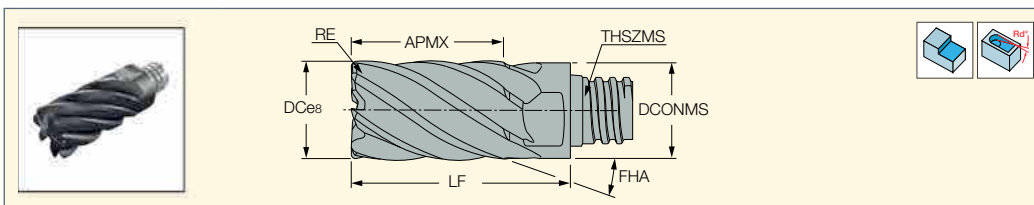

Designation	Dimensions									IC908	Recommended Machining Data f _z (mm/t)
	DC	APMX	RE	NOF ⁽¹⁾	THSZMS	DCONMS	LF	FHA	RMPX ⁽²⁾		
MM EC080H12R05CF-7T05	8.00	12.00	0.50	7	T05	7.70	18.00	36.0	3.0	●	0.03-0.10
MM EC100H15R05CF-7T06	10.00	15.00	0.50	7	T06	9.60	22.00	36.0	3.0	●	0.04-0.10
MM EC120H18R05CF-7T08	12.00	18.00	0.50	7	T08	11.70	27.00	36.0	3.0	●	0.04-0.10
MM EC160H24R08CF-9T10	16.00	24.00	0.80	9	T10	15.30	33.50	36.0	1.0	●	0.05-0.10
MM EC200H30R10CF-9T12	20.00	30.00	1.00	9	T12	18.45	41.00	36.0	1.0	●	0.05-0.10
MM EC250H37R10CF-9T15	25.00	37.00	1.00	9	T15	23.90	52.50	36.0	1.0	●	0.05-0.10

• For shanks, see pages 79-86 • For clamping keys (to be ordered separately), tightening torques and clamping instructions, see pages 10-11

• Do not apply lubricant to the threaded connection • For user guide, see pages 9,12-13

⁽¹⁾ Number of flutes

⁽²⁾ Maximum ramping angle



MM ECK-CF
5,6 Flute Solid Carbide Heads with 35°/38° Helix Featuring Different Corner Radii For Machining Titanium Alloys

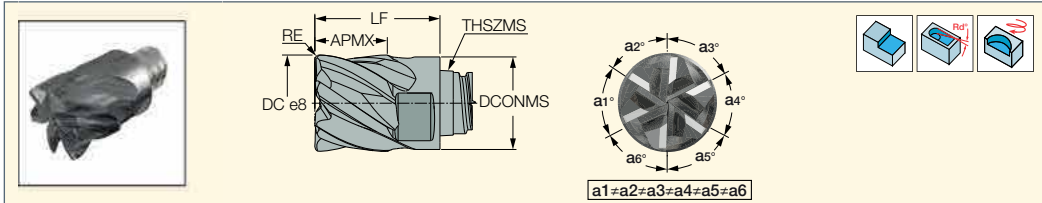

Designation	Dimensions									IC908	Recommended Machining Data f _z (mm/t)
	DC	RE	NOF ⁽¹⁾	APMX	THSZMS	DCONMS	LF	RMPX ^{°(2)}	f _z		
MM ECK080H05R04-6T05CF	8.00	0.40	6	5.00	T05	7.70	10.00	5.0	●	0.04-0.08	
MM ECK100H07R05-6T06CF	10.00	0.50	6	7.00	T06	9.60	13.00	5.0	●	0.04-0.08	
MM ECK120H09R05-6T08CF	12.00	0.50	6	9.00	T08	11.70	16.50	5.0	●	0.04-0.08	
MM ECK160H12R08-6T10CF	16.00	0.80	6	12.00	T10	15.30	20.50	5.0	●	0.07-0.12	
MM ECK200H15R10-6T12CF	20.00	1.00	6	15.00	T12	18.45	25.50	5.0	●	0.07-0.12	
MM ECK250H22R10-6T15CF	25.00	1.00	6	22.00	T15	23.90	37.00	5.0	●	0.07-0.12	
MM ECK320H38R4-5T21	32.00	4.00	5	38.00	T21	30.00	55.00	1.0	●	0.06-0.18	
MM ECK320H38R5-5T21	32.00	5.00	5	38.00	T21	30.00	55.00	1.0	●	0.06-0.18	

- For shanks, see pages 79-86
- For clamping keys (should be ordered separately), tightening torques and clamping instructions, see pages 10-11
- Do not apply lubricant to the threaded connection.
- For user guide, see pages 9,12-13

⁽¹⁾ Number of flutes
⁽²⁾ Maximum ramping angle



MM HC
Interchangeable Solid Carbide Slot Drill Milling Heads with Two 10° Helix Flutes

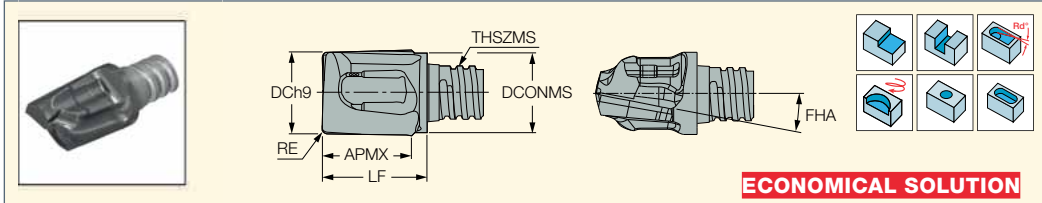

ECONOMICAL SOLUTION

Designation	Dimensions										Tough ↔ Hard		Recommended Machining Data f _z (mm/t)
	DC	NOF ⁽¹⁾	APMX	RE	Tm ⁽²⁾	THSZMS	DCONMS	LF	FHA	IC908	IC903	f _z	
MM HC078C08R0.2-2T05	7.80	2	7.70	0.20	r0-2.0	T05	7.60	10.00	10.0	●	●	0.03-0.09	
MM HC080C08R0.4-2T05	8.00	2	7.70	0.40	r0-2.0	T05	7.60	10.00	10.0	●	●	0.03-0.09	
MM HC080C08R1.0-2T05	8.00	2	7.70	1.00	r0-2.0	T05	7.60	10.00	10.0	●	●	0.03-0.09	
MM HC080C08R2.0-2T05	8.00	2	7.70	2.00	r0-2.0	T05	7.60	10.00	10.0	●	●	0.03-0.09	
MM HC098C10R0.3-2T06	9.80	2	9.00	0.30	r0-3.0	T06	9.50	12.35	10.0	●	●	0.03-0.10	
MM HC100C10R0.4-2T06	10.00	2	9.00	0.40	r0-3.0	T06	9.50	12.35	10.0	●	●	0.03-0.10	
MM HC100C10R1.0-2T06	10.00	2	9.00	1.00	r0-3.0	T06	9.50	12.35	10.0	●	●	0.03-0.10	
MM HC100C10R2.0-2T06	10.00	2	9.00	2.00	r0-3.0	T06	9.50	12.35	10.0	●	●	0.03-0.10	
MM HC117C13R0.3-2T08	11.70	2	10.00	0.30	r0-3.0	T08	11.50	14.20	10.0	●	●	0.04-0.11	
MM HC120C13R0.4-2T08	12.00	2	10.00	0.40	r0-3.0	T08	11.50	14.20	10.0	●	●	0.04-0.11	
MM HC120C13R1.0-2T08	12.00	2	10.00	1.00	r0-3.0	T08	11.50	14.20	10.0	●	●	0.04-0.11	
MM HC120C13R2.0-2T08	12.00	2	10.00	2.00	r0-3.0	T08	11.50	14.20	10.0	●	●	0.04-0.11	
MM HC140C11R0.4-2T08	14.00	2	11.60	0.40	r0-4.0	T08	11.50	15.05	10.0	●	●	0.04-0.12	
MM HC157C16R0.3-2T10	15.70	2	15.00	0.30	r0-4.0	T10	15.20	19.05	10.0	●	●	0.05-0.13	
MM HC160C16R0.4-2T10	16.00	2	14.90	0.40	r0-4.0	T10	15.20	19.05	10.0	●	●	0.05-0.13	
MM HC160C16R0.8-2T10	16.00	2	14.90	0.80	r0-4.0	T10	15.15	19.05	10.0	●	●	0.05-0.13	

- For shanks, see pages 79-86
- For clamping keys (to be ordered separately), tightening torques and clamping instructions, see pages 10-11
- Do not apply lubricant to the threaded connection.
- For user guide, see pages 9,12-13

⁽¹⁾ Number of flutes
⁽²⁾ Specially tailored radius range, available upon request.

Exchangeable Heads with Indexable Inserts

SUMOMILL
290 LINE
MULTI-MASTER

T290 ELN-MM-05
Endmills with a MULTI-MASTER
Adaptation Carrying Tangentially
Clamped Inserts

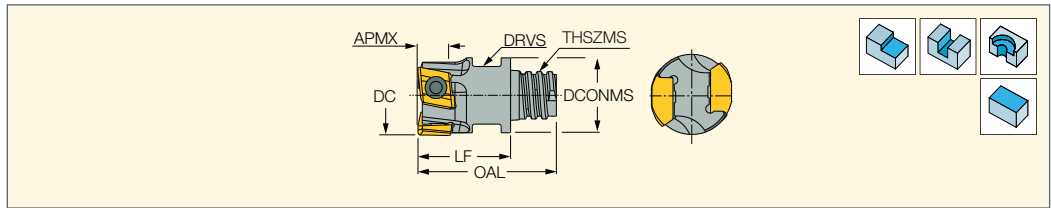

Designation	DC	CICT ⁽¹⁾	APMX	DCONMS	THSZMS	LF	OAL	DRVS ⁽²⁾	kg	SR	IP
T290 ELN D10-02-MMT06-05	10.00	2	5.00	9.20	T06	13.40	20.00	8.0	0.01	SR 10503833-S	T-7/51
T290 ELN D12-03-MMT08-05	12.00	3	5.00	11.00	T08	16.00	24.00	10.0	0.01	SR 10503833	T-7/51
T290 ELN D14-03-MMT08-05	14.00	3	5.00	13.00	T08	16.06	24.00	10.0	0.01	SR 10503833	T-7/51
T290 ELN D16-04-MMT10-05	16.00	4	5.00	14.95	T10	19.25	31.00	13.0	0.03	SR 10503833	T-7/51

• Do not apply lubricant to the MULTI-MASTER threaded connection • For adaptation see page 9 • For user guide see pages 10-11

⁽¹⁾ Number of inserts

⁽²⁾ Clamping wrench size

For inserts: T290 LNMT/LNHT 0502

For holders, see pages: MM CAB (86) • MM CAB-T-T (86) • MM CAB-T-T-W (86) • MM GRT (shanks) (81) • MM S-A (stepped shanks) (79)

• MM S-A (straight shanks) (82) • MM S-A-C# (85) • MM S-A-HSK (85) • MM S-A-N (81) • MM S-A-SK (85) • MM S-B (85° conical shanks) (82)

• MM S-D (89° conical shanks) (83) • MM S-ER (84) • MM S-ER-H (84) • MM TS-A (81)

HELIPUS
MULTI-MASTER

HP E90AN-MM-07
90° Endmills with a
MULTI-MASTER Threaded
Adaptation Carrying HELIPLUS
HP ANKT 0702... Inserts

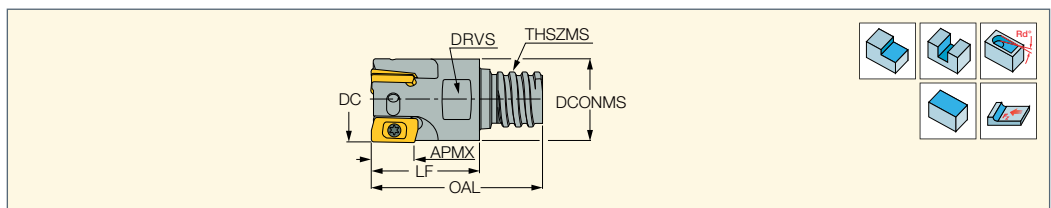

Designation	DC	CICT ⁽¹⁾	OAL	LF	APMX	THSZMS	DCONMS	DRVS ⁽²⁾	RMPX ^{°(3)}	RMPX ^{°_2(4)}	RMPX ⁽⁵⁾	kg	SR	IP
HP E90AN-D12-2-MMT08	12.00	2	24.45	16.50	7.70	T08	10.60	10.0	2.7	3.5	56970	0.01	SR 34-533/L/HG	T-6/51
HP E90AN-D16-3-MMT10	16.00	3	31.75	20.00	7.70	T10	14.95	13.0	3.2	6.0	44860	0.03	SR 34-533/L/HG	T-6/51
HP E90AN-D16-4-MMT10	16.00	4	31.75	20.00	7.70	T10	14.95	13.0	3.2	6.0	37630	0.03	SR 34-533/L/HG	T-6/51
HP E90AN-D20-5-MMT12	20.00	5	35.30	21.50	7.70	T12	18.40	16.0	2.4	4.5	38890	0.05	SR 34-533/L/HG	T-6/51

• Do not apply lubricant to the MULTI-MASTER threaded connection • For adaptation see page 9 • For user guide see pages 10-11

⁽¹⁾ Number of inserts

⁽²⁾ Clamping wrench size

⁽³⁾ Maximum ramping angle

⁽⁴⁾ Values only for HP ANKT 0702R12T-FF insert

⁽⁵⁾ Maximum RPM

For inserts: HP ANCR 0702PNFR • HP ANKT 0702-FF • HP ANKT/ANCT 0702 PN-R/PNTR • HP ANKW 070204PNTR

For holders, see pages: MM CAB (86) • MM GRT (shanks) (81) • MM S-A (stepped shanks) (79) • MM S-A (straight shanks) (82)

• MM S-A-C# (85) • MM S-A-HSK (85) • MM S-A-N (81) • MM S-A-SK (85) • MM S-B (85° conical shanks) (82) • MM S-D (89° conical shanks) (83)

• MM S-ER (84) • MM S-ER-H (84) • MM TS-A (81)

HELITANG
T490 LINE
MULTI-MASTER

T490 ELN-MM-08
90° Endmills with a
MULTI-MASTER Threaded
Adaptation Carrying
Tangentially Clamped Inserts

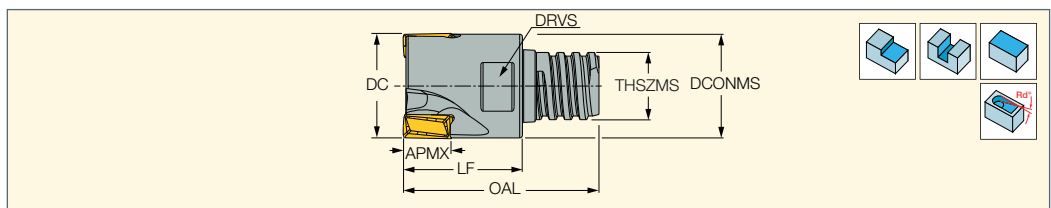

Designation	DC	CICT ⁽¹⁾	APMX	DCONMS	LF	OAL	THSZMS	DRVS ⁽²⁾	RMPX ^{°(3)}	RMPX ^{°_2(4)}	kg	SR	IP
T490 ELN D16-2-MMT10	16.00	2	8.00	14.70	20.00	32.00	T10	13.0	2.0	1.1	0.03	SR 10502813-HGSM	IP-7/51
T490 ELN D20-3-MMT12	20.00	3	8.00	18.70	22.00	35.00	T12	16.0	1.7	0.8	0.05	SR 10502813-HG-M	IP-7/51

• Do not apply lubricant to the MULTI-MASTER threaded connection • For adaptation see page 9 • For user guide see pages 10-11

⁽¹⁾ Number of inserts

⁽²⁾ Clamping wrench size

⁽³⁾ Maximum ramping angle - valid only with T490 LNHT 080404PNR-RD inserts

⁽⁴⁾ Maximum ramping angle - valid only with T490 LNMT 080404PNR-RD inserts

For inserts: T490 LNAR-P • T490 LNMT/LNHT 0804

For holders, see pages: MM S-A (stepped shanks) (79) • MM S-A (straight shanks) (82) • MM S-A-C# (85) • MM S-A-HSK (85)

• MM S-A-N (81) • MM S-A-SK (85) • MM S-B (85° conical shanks) (82) • MM S-D (89° conical shanks) (83) • MM S-ER (84) • MM S-ER-H (84) • MM TS-A (81)

HELIDO
490 LINE
MULTI-MASTER

H490 E90AX-MM
90° Endmills with a MULTI-MASTER Threaded Connection Carrying H490 ANKX/ANCX 090... Double-Sided Rectangular Inserts

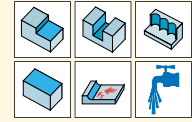
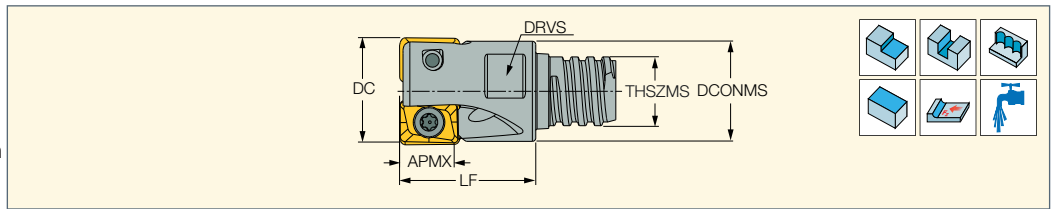

Designation	DC	CICT ⁽¹⁾	APMX	LF	DCONMS	THSZMS	DRVS ⁽²⁾	kg			
H490 E90AX D20-3-MMT12-09	20.00	3	8.00	24.70	18.70	T12	16.0	0.05	SR 10508082-HG	BLD T08/M7	SW4-SD

• Do not apply lubricant to the MULTI-MASTER threaded connection • For adaptation, see page 9 • For user guide, see pages 10-11

⁽¹⁾ Number of inserts

⁽²⁾ Clamping wrench size

For inserts: H490 ANKX 0904-FF • H490 ANKX/ANCX-09

For holders, see pages: MM S-A (stepped shanks) (79) • MM S-A (straight shanks) (82) • MM S-A-C# (85) • MM S-A-HSK (85)

• MM S-A-SK (85) • MM S-B (85° conical shanks) (82) • MM S-D (89° conical shanks) (83) • MM S-ER (84) • MM S-ER-H (84)

HELi2000
MULTI-MASTER

HM90 E90A-MM-10
90° Endmills with a MULTI-MASTER Threaded Adaptation Carrying HM90 AP.. 1003... Inserts

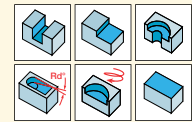
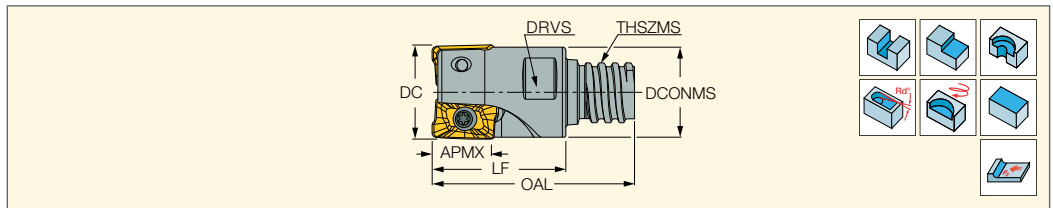

Designation	DC	CICT ⁽¹⁾	APMX	OAL	RMPX ^{o(2)}	LF	THSZMS	DRVS ⁽³⁾	DCONMS	kg		
HM90 E90A-D16-2-MMT10	16.00	2	10.00	34.75	15.0	23.00	T10	13.0	15.30	0.03	SR 34-505/HG	
HM90 E90A-D20-2-MMT12	20.00	2	10.00	38.30	7.5	24.60	T12	16.0	19.20	0.05	SR 34-505/HG	T-8/53
HM90 E90A-D20-3-MMT12	20.00	3	10.00	38.30	7.5	24.60	T12	16.0	19.20	0.05	SR 34-505/HG	

• Do not apply lubricant to the MULTI-MASTER threaded connection • For adaptation see page 9 • For user guide see pages 10-11

⁽¹⁾ Number of inserts

⁽²⁾ Maximum ramping angle

⁽³⁾ Clamping wrench size

For inserts: APCR 1003PDFR-P • APCT 1003PDR-HM • APKR 1003PDR • APKT 1003-FF • APKT 1003..R • APKT 1003..TR-RM • APKT 1003PDR-HM

• **APKT 1003PDR-HM-CS • APKT 1003PDTR-76 • APKT 1003PDTR/L-RM • APKW 100304 PDR (PCD) • HM90 APCR 100304PDFR-P/DP • HM90 APCT 1003**

• **HM90 APKT 1003 • HM90 APKT 1003PD-W • HM90 APKW 1003PDR**

For holders, see pages: MM S-A (stepped shanks) (79) • MM S-A (straight shanks) (82) • MM S-A-C# (85) • MM S-A-HSK (85)

• MM S-A-N (81) • MM S-A-SK (85) • MM S-B (85° conical shanks) (82) • MM S-D (89° conical shanks) (83) • MM S-ER (84) • MM S-ER-H (84) • MM TS-A (81)

HELi4MILL
MULTI-MASTER

E90SO-MM-04
Endmills with a MULTI-MASTER Connection Carrying Inserts for Shouldering and Fast Feed Applications

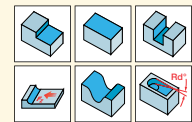
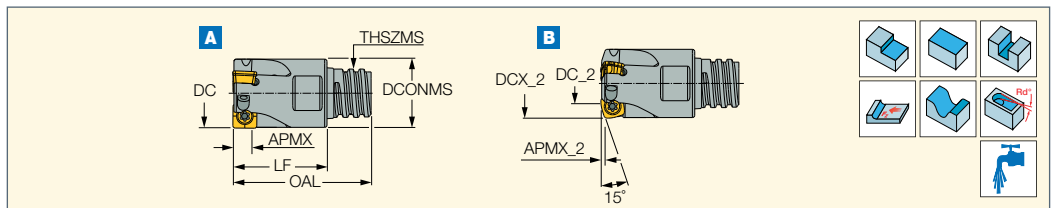

Designation	DC	APMX	DC_2	DCX_2	APMX_2	LF	OAL	CICT ⁽¹⁾	DCONMS	THSZMS	DRVS ⁽²⁾	RMPX ^{o(3)}	MIID ⁽⁴⁾	MIID_2 ⁽⁵⁾	kg
E90SO D10-2-MMT06-04	10.00	3.50	3.90	10.17	0.50	15.00	21.30	2	9.70	T06	8.0	6.0	SOMT 040204 PNTR	SOMT 040208 PNR-FF	0.05
E90SO D12-3-MMT08-04	12.00	3.50	5.90	12.17	0.50	16.00	23.50	3	11.60	T08	10.0	3.0	SOMT 040204 PNTR	SOMT 040208 PNR-FF	0.15
E90SO D14-4-MMT08-04	14.00	3.50	7.90	14.17	0.50	16.00	23.50	4	13.60	T08	10.0	2.0	SOMT 040204 PNTR	SOMT 040208 PNR-FF	0.01
E90SO D16-5-MMT10-04	16.00	3.50	9.90	16.17	0.50	18.00	29.30	5	15.60	T10	13.0	2.0	SOMT 040204 PNTR	SOMT 040208 PNR-FF	0.03
E90SO D20-6-MMT12-04	20.00	3.50	13.90	20.17	0.50	25.00	38.80	6	19.60	T12	16.0	1.0	SOMT 040204 PNTR	SOMT 040208 PNR-FF	0.08

• A - with SOMT/CT 0402 insert • B - with SOMT 0402-FF insert (pocket seat must be modified) • Tightening torque 0.5 Nxm

⁽¹⁾ Number of inserts

⁽²⁾ Torque key size

⁽³⁾ Maximum ramping angle - valid only with SOMT 040208 PNR-FF insert

⁽⁴⁾ Master insert identification

⁽⁵⁾ Master insert identification 2

For inserts: SOMT 0402-FF • SOMT/CT 0402

For holders, see pages: MM CAB (86) • MM CAB-T (86) • MM CAB-T-T-W (86) • MM GRT (shanks) (81) • MM S-A (stepped shanks) (79)

• MM S-A (straight shanks) (82) • MM S-A-C# (85) • MM S-A-HSK (85) • MM S-A-N (81) • MM S-A-SK (85) • MM S-B (85° conical shanks) (82)

• MM S-D (89° conical shanks) (83) • MM S-ER (84) • MM S-ER-H (84) • MM TS-A (81)

Spare Parts

Designation		
E90SO-MM-04	TS 18041/HG	T-6P/51

HM390 ETP-MM-04
90° Endmills with a MULTI-MASTER
Threaded Adaptation
Carrying HM390 TPKR
0401... Triangular Inserts

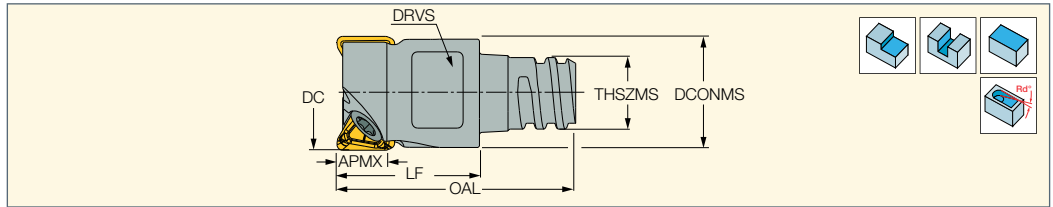

Designation	DC	APMX	CICT ⁽¹⁾	LF	DCONMS	THSZMS	OAL	DRVS ⁽²⁾	RMPX ⁽³⁾	kg
HM390 ETP D08-2-MMT05-04	8.00	3.00	2	10.00	7.60	T05	16.75	5.5	3.0	0.04
HM390 ETP D10-3-MMT06-04	10.00	3.00	3	12.00	9.60	T06	18.30	8.0	2.5	0.04

• Insert tightening torque 0.5 N*m • For adaptation, see page 9 • For user guide, see pages 10-11

⁽¹⁾ Number of inserts

⁽²⁾ Clamping wrench size

⁽³⁾ Maximum ramping angle

For inserts: HM390 TPKR 0401

For holders, see pages: MM CAB (86) • MM CAB-T-T (86) • MM CAB-T-T-W (86) • MM GRT (shanks) (81) • MM S-A (stepped shanks) (79)
• MM S-A (straight shanks) (82) • MM S-A-C# (85) • MM S-A-HSK (85) • MM S-A-N (81) • MM S-A-SK (85) • MM S-B (85° conical shanks) (82)
• MM S-D (89° conical shanks) (83) • MM S-ER (84) • MM S-ER-H (84) • MM TS-A (81)

Spare Parts

Designation		
HM390 ETP D08-2-MMT05-04	SR M2X0.4-3 T6	T-6/5 MAGNET 3X3
HM390 ETP D10-3-MMT06-04	SR M2X0.4-3.5 T6	T-6/5 MAGNET 3X3

HM390 ETC-MM
90° Endmills with a
MULTI-MASTER Threaded
Adaptation Carrying HM390
TCKT 0703 Triangular Inserts

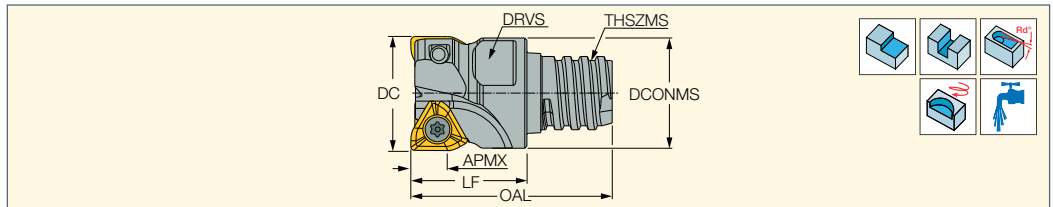

Designation	DC	APMX	CICT ⁽¹⁾	LF	DCONMS	THSZMS	OAL	DRVS ⁽²⁾	RMPX ⁽³⁾	kg		
HM390 ETC D16-2-MMT10-07	16.00	5.00	2	16.00	15.20	T10	27.30	13.0	1.9	0.02	SR M2.5X6-T7-60	T-7/51
HM390 ETC D20-3-MMT12-07	20.00	5.00	3	20.00	18.30	T12	33.30	16.0	1.4	0.04	SR M2.5X6-T7-60	T-7/51
HM390 ETC D25-4-MMT15-07	25.00	5.00	4	25.00	23.90	T15	42.00	20.0	1.0	0.08	SR M2.5X6-T7-60	T-7/51

• Insert clamping screw must be lubricated every indexing. • Tightening torque 0.9 Nxm. • For adaptation see page 9 • For user guide see pages 10-11

⁽¹⁾ Number of inserts

⁽²⁾ Clamping wrench size

⁽³⁾ Maximum ramping angle

For inserts: HM390 TCKT/CT 0703

For holders, see pages: MM S-A (stepped shanks) (79) • MM S-A (straight shanks) (82) • MM S-A-C# (85) • MM S-A-HSK (85)
• MM S-A-N (81) • MM S-A-SK (85) • MM S-B (85° conical shanks) (82) • MM S-D (89° conical shanks) (83) • MM S-ER (84) • MM S-ER-H (84) • MM TS-A (81)

HM390 ETP-MM-05
90° Endmills with a
MULTI-MASTER Threaded
Adaptation Carrying HM390
TPKT 0502... Triangular Inserts

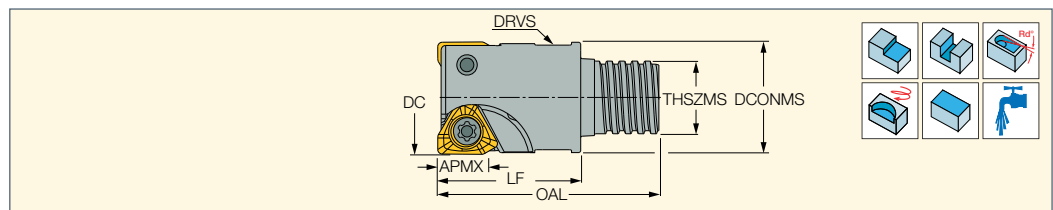

Designation	DC	APMX	CICT ⁽¹⁾	LF	DCONMS	THSZMS	OAL	DRVS ⁽²⁾	RMPX ⁽³⁾	kg
HM390 ETP D10-02-MMT06-05	10.00	3.50	2	15.00	9.60	T06	21.60	8.0	2.0	0.01
HM390 ETP D12-03-MMT08-05	12.00	3.50	3	16.00	11.60	T08	24.20	10.0	1.5	0.00
HM390 ETP D14-03-MMT08-05	14.00	3.50	3	16.00	13.60	T08	22.90	10.0	1.5	0.01
HM390 ETP D16-04-MMT10-05	16.00	3.50	4	18.00	15.60	T10	29.80	13.0	1.5	0.03

• Insert tightening torque 0.5 N*m • For adaptation, see page 9 • For user guide, see pages 10-11

⁽¹⁾ Number of inserts

⁽²⁾ Clamping wrench size

⁽³⁾ Maximum ramping angle

For inserts: HM390 TPKT/CT 0502

For holders, see pages: MM CAB (86) • MM CAB-T-T (86) • MM CAB-T-T-W (86) • MM GRT (shanks) (81) • MM S-A (stepped shanks) (79) • MM S-A (straight shanks) (82)
• MM S-A-C# (85) • MM S-A-HSK (85) • MM S-A-N (81) • MM S-A-SK (85) • MM S-B (85° conical shanks) (82)
• MM S-D (89° conical shanks) (83) • MM S-ER (84) • MM S-ER-H (84) • MM TS-A (81)

Spare Parts

Designation		
HM390 ETP-MM-05	TS 18041/HG	T-6IP/51

HELI2000
JET LINE
MULTI-MASTER

HM90 E90A-MM-10-JHP
90° JHP Endmills with a MULTI-MASTER Threaded Adaptation Carrying HELI2000 and HELIMILL Inserts

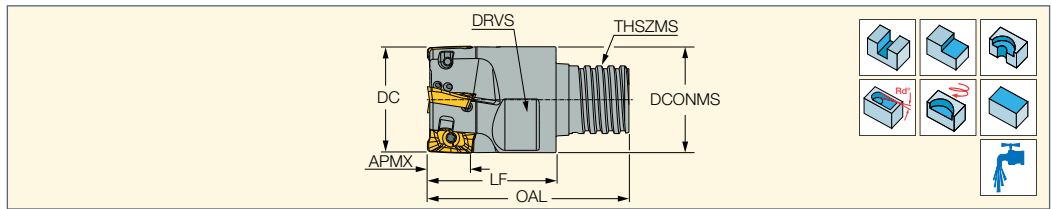

Designation	DC	CICT ⁽¹⁾	APMX	OAL	RMPX ⁽²⁾	LF	THSZMS	TQ_3 ⁽³⁾	DRVS ⁽⁴⁾	DCONMS	MIID ⁽⁵⁾	
HM90 E90A D16-2-MMT10-JHP	16.00	2	10.00	34.80	15.0	23.40	T10	28	13.0	15.60	APKT 1003PDR-HM	0.10
HM90 E90A D20-3-MMT12-JHP	20.00	3	10.00	38.50	7.5	25.50	T12	28	16.0	19.70	APKT 1003PDR-HM	0.15
HM90 E90A D25-4-MMT15-JHP	25.00	4	10.00	47.00	7.5	30.00	T15	40	20.0	24.70	APKT 1003PDR-HM	0.05
HM90 E90A D32-5-MMT21-JHP	32.00	5	10.00	57.95	3.0	34.85	T21	110	24.0	30.10	APKT 1003PDR-HM	0.00

• Do not apply lubricant to the MULTI-MASTER threaded connection • For adaptation see page 9 • For user guide see pages 10-11

- ⁽¹⁾ Number of inserts
- ⁽²⁾ Maximum ramping angle
- ⁽³⁾ Maximum RPM
- ⁽⁴⁾ Torque key size
- ⁽⁵⁾ Tool tightening torque Nxm (lbfxin)

For inserts: APCR 1003PDFR-P • APCT 1003PDR-HM • APKR 1003PDR • APKT 1003-FF • APKT 1003..R • APKT 1003..TR-RM • APKT 1003PDR-HM • APKT 1003PDR-HM-CS • APKT 1003PDTR-76 • APKT 1003PDTR/L-RM • HM90 APCR 100304PDFR-P/DP • HM90 APCT 1003 • HM90 APKT 1003 • HM90 APKT 1003PD-W • HM90 APKW 1003PDR

For holders, see pages: MM S-A (stepped shanks) (79) • MM S-A (straight shanks) (82) • MM S-A-C# (85) • MM S-A-HSK (85) • MM S-A-N (81) • MM S-A-SK (85) • MM S-B (85° conical shanks) (82) • MM S-D (89° conical shanks) (83) • MM S-ER (84) • MM S-ER-H (84) • MM TS-A (81)

Spare Parts

Designation				
HM90 E90A-MM-10-JHP	SR 34-505/HG	SR 34-505/HG ^(a)	BLD T08/M7	SW4-SD

^(a) Recommended tightening torque for this item: 1.2 Nxm

BALLPLUS
MULTI-MASTER

HCE-MM
Multifunction Endmills with a MULTI-MASTER Threaded Adaptation that Mounts Several Insert Geometries

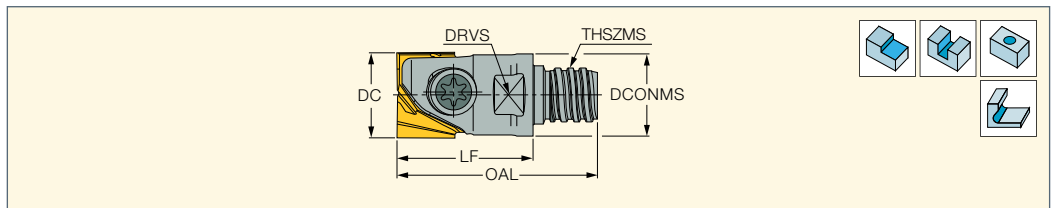

Designation	DC	OAL	LF	APMX	THSZMS	DCONMS	DRVS ⁽¹⁾	TQ				
HCE D12/.50-MMT08	12.00	28.00	20.00	8.10	T08	11.50	10.0	15.0	0.01	SR 34-540	BLD T15/S7	SW6-T
HCE D16/.62-MMT10	16.00	36.75	25.00	10.30	T10	15.20	13.0	28.0	0.03	SR 10503579	BLD T20/S7	SW6-T
HCE D20/.75-MMT12	20.00	48.80	35.00	12.80	T12	18.50	15.0	28.0	0.06	SR 1052964	BLD T25/S7	SW6-T

• For undercutting, use HTR inserts only • The dimensions are for HCC inserts with RE=0.5 mm • Do not apply lubricant to the MULTI-MASTER threaded connection • For adaptation options, see page • For user guide, see pages 10-11

⁽¹⁾ Width across flats (wrench should be ordered separately)

For inserts: HCC-QF

For holders, see pages: MM CAB (86) • MM GRT (shanks) (81) • MM S-A (stepped shanks) (79) • MM S-A (straight shanks) (82) • MM S-A-C# (85) • MM S-A-HSK (85) • MM S-A-N (81) • MM S-A-SK (85) • MM S-B (85° conical shanks) (82) • MM S-D (89° conical shanks) (83) • MM S-ER (84) • MM S-ER-H (84) • MM TS-A (81)

90° Endmills with a
MULTI-MASTER Threaded
Connection Carrying H690 WNMU
0403 Double-Sided Trigonal Inserts

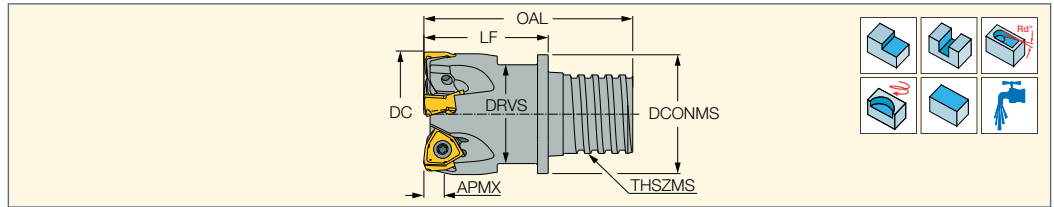

Designation	DC	APMX	CICT ⁽¹⁾	LF	DCONMS	THSZMS	OAL	DRVS ⁽²⁾	RMPX ^{o(3)}	TQ_3 ⁽⁴⁾	
H690 EWN D20-3-MMT12-R04	20.00	4.00	3	20.00	18.30	T12	33.00	16.0	1.5	28	0.07
H690 EWN D25-5-MMT15-R04	25.00	4.00	5	25.00	23.90	T15	42.00	20.0	1.1	40	0.12

• Insert clamping screw must be lubricated every indexing. • For adaptation see page 9 • For user guide see pages 10-11

⁽¹⁾ Number of inserts

⁽²⁾ Clamping wrench size

⁽³⁾ Maximum ramping angle



⁽⁴⁾ Tool tightening torque (Nxm)

For inserts: H690 WNMU 0403

For holders, see pages: MM S-A (stepped shanks) (79) • MM S-A (straight shanks) (82) • MM S-A-C# (85) • MM S-A-HSK (85)

• MM S-A-SK (85) • MM S-B (85° conical shanks) (82) • MM S-D (89° conical shanks) (83) • MM S-ER (84) • MM S-ER-H (84) • MM TS-A (81)

Spare Parts

Designation		
H690 EWN-MM-04	SR M2.5X6-T7-60 ^(a)	T-7/51

^(a) Tightening torque 0.9 Nxm

Exchangeable Solid Carbide Head

MULTI-^{FEED}MASTER

MM FF

Interchangeable 2 Flute FEEDMILL Solid Carbide Heads for Milling at Very Fast Feeds and Small D.O.C.

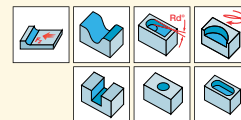
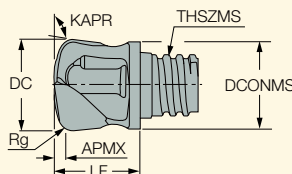

ECONOMICAL SOLUTION

Designation	Dimensions									Tough ↔ Hard		Recommended Machining Data f _z (mm/t)
	DC	NOF ⁽¹⁾	APMX	Rg ⁽²⁾	THSZMS	DCONMS	LF	KAPR ⁽³⁾	RMPX ⁽⁴⁾	IC908	IC903	
MM FF100R1.5-L12-2T06	10.00	2	0.60	2.00	T06	9.60	12.50	97.0	7.0	●		0.30-0.60
MM FF120R2.0-2T08	12.00	2	0.68	2.50	T08	11.50	11.10	97.0	7.0	●	●	0.50-1.00
MM FF500R08-L59-2T08	12.70	2	0.68	2.50	T08	11.50	15.00	95.0	7.0	●		0.50-1.00
MM FF160R2.0-2T10	16.00	2	1.10	3.00	T10	15.20	13.50	97.0	7.0	●		0.55-1.10
MM FF200R2.0-2T12	20.00	2	1.50	3.40	T12	18.45	17.40	95.0	7.0	●		0.75-1.50

- For shanks, see pages 79-86
- For clamping keys (to be ordered separately), tightening torques and clamping instructions, see pages 10-11
- Do not apply lubricant to the threaded connection.
- For user guide, see pages 9,12-13

⁽¹⁾ Number of flutes

⁽²⁾ Radius for programming

⁽³⁾ Tool cutting edge angle

⁽⁴⁾ Maximum ramping angle

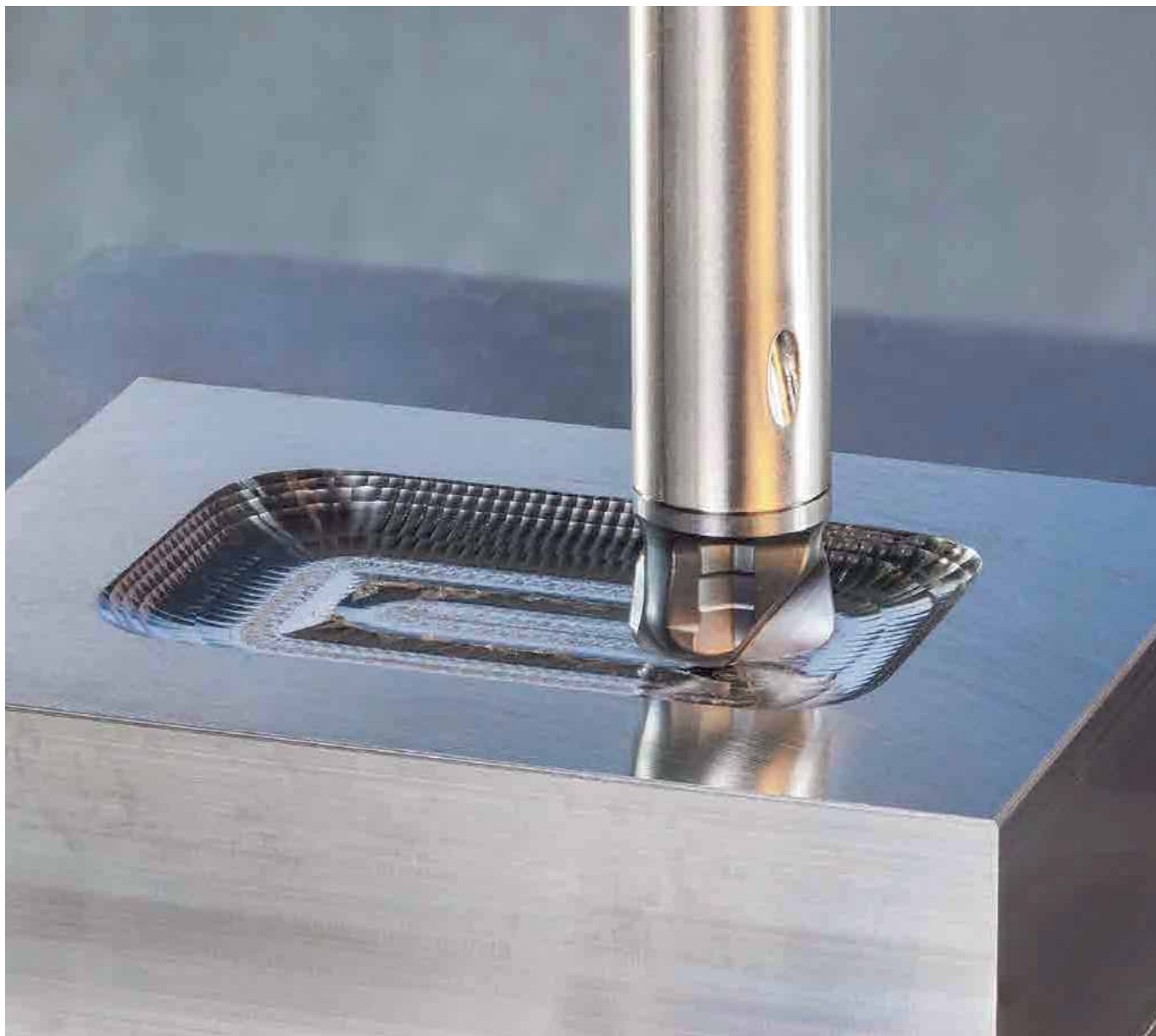

MM EFF

4, 6 Flute Solid Carbide Heads for Milling at Very Fast Feeds and Small D.O.C.

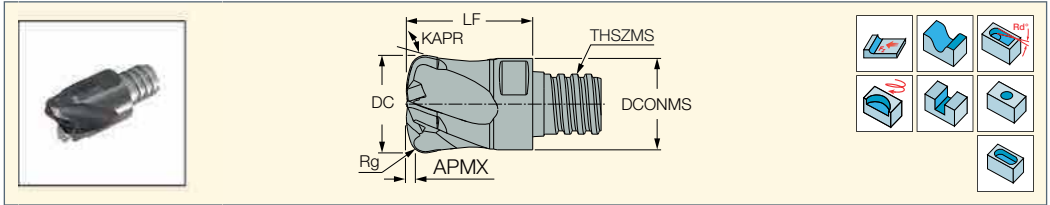

Designation	Dimensions										Tough ↔ Hard		Recommended Machining Data f _z (mm/t)
	DC	NOF ⁽³⁾	APMX	THSZMS	DCONMS	LF	RMPX ⁽⁴⁾	KAPR ⁽⁵⁾	Rg ⁽⁶⁾	CSP ⁽⁷⁾	IC908	IC903	
MM EFF080T3R1.62-4T05	8.00	4	0.40	T05	7.50	10.00	5.0	97.0	1.62	0		●	0.12-0.48
MM EFF100T4R2.01-4T06	10.00	4	0.50	T06	9.50	13.00	5.0	97.0	2.01	0		●	0.16-0.57
MM EFF100T2R1.0-6T06H ⁽¹⁾	10.00	6	0.45	T06	9.50	10.00	3.0	97.0	1.00	1		●	0.16-0.47
MM EFF120T4R1.8-4T08H ⁽¹⁾	12.00	4	0.60	T08	11.50	16.50	5.0	97.0	1.80	1	●		0.16-0.67
MM EFF120T4R2.47-4T08	12.00	4	0.60	T08	11.50	16.50	5.0	97.0	2.47	0		●	0.16-0.67
MM EFF120T2R1.2-6T08H ⁽¹⁾	12.00	6	0.65	T08	11.50	12.50	3.0	97.0	1.20	1		●	0.16-0.54
MM EFF127T4R2.59-4T08	12.70	4	0.60	T08	12.20	16.50	5.0	97.0	2.59	0		●	0.16-0.67
MM EFF127T4R1.3-6T08H	12.70	6	0.70	T08	12.20	12.70	3.0	97.0	1.30	1		●	0.16-0.67
MM EFF160T5R2.2-4T10H ⁽¹⁾	16.00	4	0.80	T10	15.40	20.50	5.0	97.0	2.20	1	●		0.20-0.75
MM EFF160T5R3.25-4T10	16.00	4	0.80	T10	15.40	20.50	5.0	97.0	3.25	0		●	0.20-0.75
MM EFF160T4R2.0-6T10H ⁽¹⁾	16.00	6	1.05	T10	15.40	16.00	3.0	97.0	2.00	1		●	0.20-0.65
MM EFF200T6R4.02-4T12	20.00	4	1.00	T12	18.45	25.50	5.0	97.0	4.02	0		●	0.20-0.90
MM EFF200T5R2.2-6T12H ⁽¹⁾	20.00	6	1.25	T12	18.45	20.00	3.0	97.0	2.20	1		●	0.20-0.80
MM EFF250A7R3.1-6T15 ⁽²⁾	25.00	6	1.20	T15	23.90	25.00	5.0	97.0	3.10	0		●	0.25-1.00
MM EFF254A7R3.1-6T15 ⁽²⁾	25.40	6	1.20	T15	23.90	25.00	5.0	97.0	3.10	0		●	0.25-1.00

• For shanks, see pages 79-86 • For clamping keys (to be ordered separately), tightening torques and clamping instructions, see pages 10-11

• Do not apply lubricant to the threaded connection. • For user guide, see pages 9,12-13

⁽¹⁾ With a central coolant hole

⁽²⁾ Cannot be used for plunging application

⁽³⁾ Number of flutes

⁽⁴⁾ Maximum ramping angle

⁽⁵⁾ Tool cutting edge angle

⁽⁶⁾ Radius for programming

⁽⁷⁾ 0 - Without coolant supply, 1 - With coolant supply

Multi Master Machining Recommendations for MM EFF Heads

VDI 3323	Material Group ⁽¹⁾	v _c (m/min)	f _z (mm/t) vs. Tool Diameter (mm)							
			a _p	a _e	8	10	12	16	20	25
P	1	180	0.045xD	0.7xD	0.48	0.57	0.67	0.75	0.90	1.00
	2	160	0.045xD	0.7xD	0.48	0.57	0.67	0.75	0.90	1.00
	3	160	0.045xD	0.7xD	0.48	0.57	0.67	0.75	0.90	1.00
	4	160	0.045xD	0.7xD	0.48	0.57	0.67	0.75	0.90	1.00
	5	150	0.045xD	0.7xD	0.43	0.50	0.57	0.65	0.75	0.87
	6	150	0.045xD	0.7xD	0.33	0.40	0.48	0.57	0.67	0.78
	7	140	0.045xD	0.7xD	0.33	0.40	0.48	0.57	0.67	0.78
	8	140	0.045xD	0.7xD	0.30	0.35	0.43	0.52	0.60	0.70
	9	140	0.045xD	0.7xD	0.30	0.35	0.43	0.52	0.60	0.70
	10	130	0.04xD	0.6xD	0.28	0.33	0.38	0.48	0.57	0.67
	11	120	0.04xD	0.6xD	0.25	0.30	0.35	0.43	0.52	0.62
K	12, 13	120	0.04xD	0.6xD	0.30	0.35	0.43	0.52	0.60	0.70
	15-16	180	apmax	0.7xD	0.45	0.52	0.60	0.70	0.80	0.90
H	17-18	160	apmax	0.7xD	0.38	0.45	0.52	0.60	0.70	0.80
	38.1 ⁽²⁾	100	0.035xD	0.45xD	0.20	0.25	0.33	0.40	0.48	0.55
	38.2 ⁽³⁾	80	0.03xD	0.3xD	0.16	0.22	0.30	0.38	0.45	0.52
	39 ⁽⁴⁾	60	0.02xD	0.25xD	0.12	0.16	0.16	0.20	0.20	0.25

⁽¹⁾ ISCAR material group in accordance with VDI 3323 standard

⁽²⁾ 45-49 HRC

⁽³⁾ 50-55 HRC

⁽⁴⁾ 56-63 HRC

a_p - maximum depth of cut

a_e - maximum width of cut

Exchangeable Heads with Indexable Inserts



FFT3 EFM-MM 02
Small Diameter Endmills with a MULTI-MASTER Threaded Adaptation that Mount Triangular Inserts for Fast Feed Milling

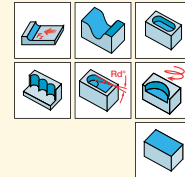
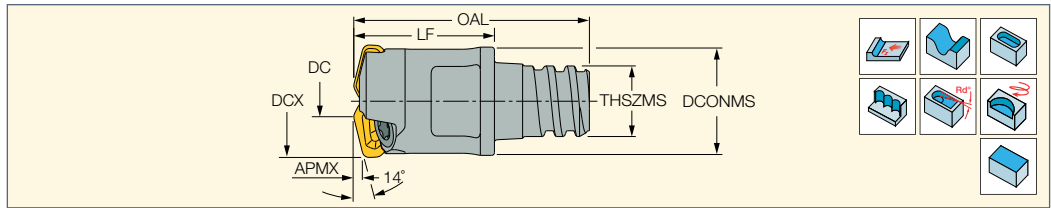

Designation	DCX ⁽¹⁾	DC	APMX	AE ⁽²⁾	CICT ⁽³⁾	LF	DCONMS	THSZMS	OAL	DRVS ⁽⁴⁾	RMPX ⁽⁵⁾	MDN ⁽⁶⁾	MDX ⁽⁷⁾	MIID ⁽⁸⁾	TQ ⁽⁹⁾
FFT3 EFMD08/.31-2MMT05-02	8.00	2.20	0.60	2.9	2	10.00	7.60	T05	16.75	5.5	10.8	10.20	15.00	FFT3 TXMT 0201205T	0.5 0.01
FFT3 EFMD10/.39-3MMT06-02	10.00	4.20	0.60	2.9	3	10.00	9.70	T06	16.30	8.0	4.7	14.20	19.00	FFT3 TXMT 0201205T	0.5 0.01

• For adaptation, see page 9 • For user guide, see pages 10-11 • Radius for programming 1.1 mm • To generate a straight surface without cusps, the width of cut must not exceed DC

- (1) Cutting diameter maximum
- (2) Maximum plunging width
- (3) Number of inserts
- (4) Torque key size
- (5) Maximum ramping angle
- (6) Machinable diameter minimum for interpolation
- (7) Machinable diameter maximum for interpolation
- (8) Master insert identification
- (9) Recommended tightening torque (N*m) for insert screw

For inserts: FFT3 TXMT 02

For holders, see pages: MM CAB (86) • MM CAB-T-T (86) • MM CAB-T-T-W (86) • MM GRT (shanks) (81) • MM S-A (stepped shanks) (79) • MM S-A (straight shanks) (82) • MM S-A-C# (85) • MM S-A-HSK (85) • MM S-A-N (81) • MM S-A-SK (85) • MM S-B (85° conical shanks) (82) • MM S-D (89° conical shanks) (83) • MM S-ER (84) • MM S-ER-H (84) • MM TS-A (81)

Spare Parts

Designation		
FFT3 EFM-MM 02	SR M2X0.4-2.9 T6-HG ^(a)	T-6/5 MAGNET 3X3

(a) Recommended tightening torque: 0.5 N*m



FFT3 EFM-MM 03
Endmills with a MULTI-MASTER Threaded Adaptation Carrying Single-Sided Small Trigon Inserts for Fast Feed Milling

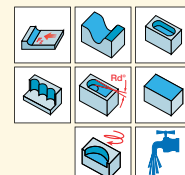
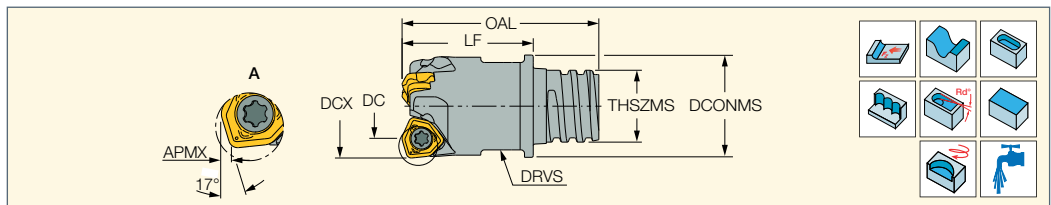

Designation	DCX ⁽¹⁾	DC	APMX	AE ⁽²⁾	CICT ⁽³⁾	LF	DCONMS	THSZMS	OAL	DRVS ⁽⁴⁾	RMPX ⁽⁵⁾	MDN ⁽⁶⁾	MDX ⁽⁷⁾	MIID ⁽⁸⁾	
FFT3 EFMD10/.39-2MMT06-03	10.00	5.60	0.60	2.2	2	10.00	9.70	T06	16.30	8.0	6.9	15.60	19.00	FFT3 WXMT 030206T	0.02
FFT3 EFMD12/.47-3MMT08-03	12.00	7.60	0.60	2.2	3	15.00	11.70	T08	22.50	10.0	4.7	19.60	23.00	FFT3 WXMT 030206T	0.03
FFT3 EFMD16/.63-4MMT10-03	16.00	11.60	0.60	2.2	4	20.00	15.30	T10	31.30	13.0	2.9	27.60	31.00	FFT3 WXMT 030206T	0.05
FFT3 EFMD20/.78-5MMT12-03	20.00	15.60	0.60	2.2	5	25.00	19.00	T12	38.30	16.0	2.0	35.60	39.00	FFT3 WXMT 030206T	0.07
FFT3 EFMD25/.98-6MMT15-03	25.00	20.60	0.60	2.2	6	30.00	24.00	T15	47.00	20.0	1.5	45.60	49.00	FFT3 WXMT 030206T	0.00

• Radius for programming 1.1 mm • To generate a straight surface without cusps, the width of cut must not exceed DC

- (1) Cutting diameter maximum
- (2) Maximum plunging width
- (3) Number of inserts
- (4) Torque key size
- (5) Maximum ramping angle
- (6) Machinable diameter minimum for interpolation
- (7) Machinable diameter maximum for interpolation
- (8) Master insert identification

For inserts: FFT3 WXMT 03

For holders, see pages: MM CAB (86) • MM CAB-T-T (86) • MM CAB-T-T-W (86) • MM GRT (shanks) (81) • MM S-A (stepped shanks) (79) • MM S-A (straight shanks) (82) • MM S-A-C# (85) • MM S-A-HSK (85) • MM S-A-N (81) • MM S-A-SK (85) • MM S-B (85° conical shanks) (82) • MM S-D (89° conical shanks) (83) • MM S-ER (84) • MM S-ER-H (84) • MM TS-A (81)

Spare Parts

Designation			
FFT3 EFM-MM 03	TS 18041/HG	TS 18041/HG ^(a)	T-6IP/51

(a) Recommended tightening torque: 0.5 Nxm

FF EWX-MM

Fast Feed Endmills with
MULTI-MASTER Threaded Connection
That Mount Double-Sided Inserts
with 6 Cutting Edges

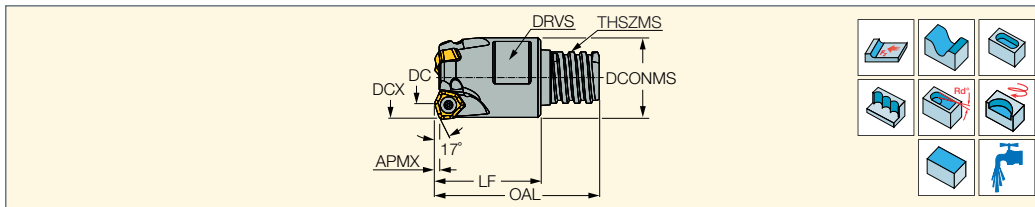

Designation	DCX ⁽¹⁾	DC	APMX	CICT ⁽²⁾	THSZMS	LF	OAL	DCONMS	DRVS ⁽³⁾	TQ ⁽⁴⁾	RMPX ⁽⁵⁾	MDN ⁽⁶⁾	MDX ⁽⁷⁾	MIID ⁽⁸⁾	
FF EWX D16-2-MMT10-04	16.00	8.60	0.80	2	T10	19.50	31.25	15.20	12.0	0.9	5.0	24.60	31.00	H600 WXCUCU 040310HP	0.02
FF EWX D20-3-MMT12-04	20.00	12.60	0.80	3	T12	25.00	38.80	18.80	15.0	0.9	4.8	32.60	39.00	H600 WXCUCU 040310HP	0.05
FF EWX D25-4-MMT15-04	25.00	17.60	0.80	4	T15	30.00	47.00	23.90	19.0	0.9	3.3	42.60	49.00	H600 WXCUCU 040310HP	0.10
FF EWX D25-3-MMT15-05	25.00	15.00	1.00	3	T15	30.00	47.00	23.90	19.0	2.0	5.0	40.00	49.00	H600 WXCUCU 05T312T	0.09

Do not apply lubricant to the MULTI-MASTER threaded connection. • To generate a straight surface without cusps, the width of cut must not exceed DC

• For adaptation options, see page 9 • For user guide, see pages 10-11

- (1) Cutting diameter maximum
- (2) Number of inserts
- (3) Width across flats (wrench should be ordered separately)
- (4) Recommended tightening torque (N*m) for insert screw
- (5) Maximum ramping angle
- (6) Machinable diameter minimum for interpolation
- (7) Machinable diameter maximum for interpolation
- (8) Master insert identification

For inserts: H600 WXCUCU

For holders, see pages: MM S-A (stepped shanks) (79) • MM S-A (straight shanks) (82) • MM S-A-C# (85) • MM S-A-HSK (85)

• MM S-A-N (81) • MM S-A-SK (85) • MM S-B (85° conical shanks) (82) • MM S-D (89° conical shanks) (83) • MM S-ER (84) • MM S-ER-H (84) • MM TS-A (81)

Spare Parts

Designation		
FF EWX D16-2-MMT10-04	SR M2.5X6-T7-60	T-7/51
FF EWX D20-3-MMT12-04	SR M2.5X6-T7-60	T-7/51
FF EWX D25-4-MMT15-04	SR M2.5X6-T7-60	T-7/51
FF EWX D25-3-MMT15-05	SR 10508600	T-9/51

FFX4 ED-MM

Endmills with MULTI-MASTER
Adaptation that Mount Small
"Bone Shaped" Inserts with 4
Cutting Edges for Fast Feed Milling

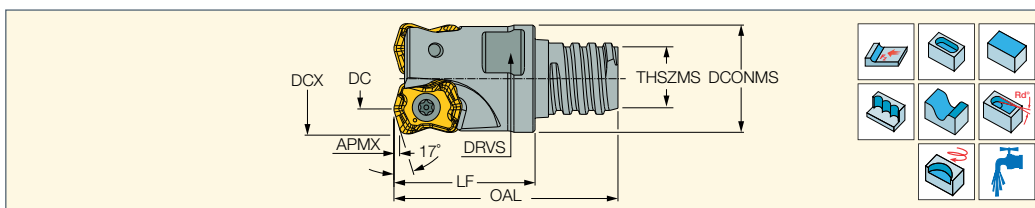

Designation	DCX ⁽¹⁾	DC	CICT ⁽²⁾	APMX	AE ⁽³⁾	THSZMS	LF	OAL	DCONMS	RMPX ⁽⁴⁾	MDN ⁽⁵⁾	MDX ⁽⁶⁾	DRVS ⁽⁷⁾	MIID ⁽⁸⁾	TQ ⁽⁹⁾	Rg ⁽¹⁰⁾	
FFX4 ED16/.63-2-MMT10-04	16.00	8.60	2	0.80	3.7	T10	20.00	31.30	15.20	4.3	24.60	31.00	13.0	FFX4 XNMU 040310T	0.9	1.80	0.02
FFX4 ED20/.78-3-MMT12-04	20.00	12.60	3	0.80	3.7	T12	25.00	38.30	18.80	2.7	32.60	39.00	15.0	FFX4 XNMU 040310T	0.9	1.80	0.04
FFX4 ED25/.98-4-MMT15-04	25.00	17.60	4	0.80	3.7	T15	30.00	47.00	24.00	1.8	42.60	49.00	19.0	FFX4 XNMU 040310T	0.9	1.80	0.14
FFX4 ED32/1.26-5-MMT21-04	32.00	24.60	5	0.80	3.7	T21	35.00	58.10	29.00	1.2	0.19	63.00	24.0	FFX4 XNMU 040310T	0.9	1.80	0.19
FFX4 ED040-6-MMT21-04	40.00	32.60	6	0.80	3.7	T21	40.00	63.10	30.00	0.9	0.30	79.00	24.0	FFX4 XNMU 040310T	0.9	1.80	0.27

• To generate a straight surface without cusps, the width of cut must not exceed DC

- (1) Cutting diameter maximum
- (2) Number of inserts
- (3) Maximum plunging width
- (4) Maximum ramping angle
- (5) Machinable diameter minimum for interpolation
- (6) Machinable diameter maximum for interpolation
- (7) Torque key size
- (8) Master insert identification
- (9) Recommended tightening torque (N*m) for insert screw
- (10) Radius for programming

For inserts: FFX4 XNMU-04

For holders, see pages: MM CAB-T-T (86) • MM CAB-T-T-W (86) • MM S-A (stepped shanks) (79) • MM S-A (straight shanks) (82) • MM S-A-C# (85) • MM S-A-HSK (85)

• MM S-A-N (81) • MM S-A-SK (85) • MM S-B (85° conical shanks) (82) • MM S-D (89° conical shanks) (83) • MM S-ER (84) • MM S-ER-H (84) • MM TS-A (81)

Spare Parts

Designation		
FFX4 ED-MM	SR M2.5X6-T7-60	T-7/51

Exchangeable Solid Carbide Heads

MULTI-MASTER
INDEXABLE SOLID CARBIDE LINE

MM HCR
Interchangeable 2 Flute Solid Carbide Ball Nose Milling Heads

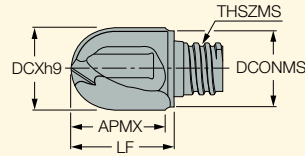

ECONOMICAL SOLUTION

Designation	Dimensions						IC908
	DCX ⁽¹⁾	NOF ⁽²⁾	APMX	THSZMS	DCONMS	LF	
MM HCR080-2T05	8.00	2	7.80	T05	7.60	9.95	●
MM HCR100-2T06	10.00	2	10.00	T06	9.50	12.35	●
MM HCR120-2T08	12.00	2	11.45	T08	11.50	15.30	●
MM HCR160-2T10	16.00	2	15.80	T10	15.20	19.10	●

- For shanks, see pages 79-86
- For clamping keys (to be ordered separately), tightening torques and clamping instructions, see pages 10-11
- Do not apply lubricant to the threaded connection.
- For user guide, see pages 9,12-13

⁽¹⁾ Cutting diameter maximum
⁽²⁾ Number of flutes

MULTI-MASTER
INDEXABLE SOLID CARBIDE LINE

MM HRF
Interchangeable 2 Flute Solid Carbide Ball Nose Finishing Milling Heads

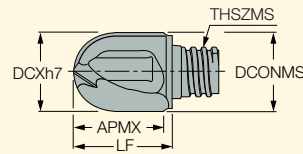

Designation	Dimensions						Tough ← Hard	
	DCX ⁽¹⁾	NOF ⁽²⁾	APMX	THSZMS	DCONMS	LF	IC908	IC903
MM HRF080-2T05	8.00	2	7.60	T05	7.60	9.95		●
MM HRF100-2T06	10.00	2	10.20	T06	9.50	12.35	●	●
MM HRF120-2T08	12.00	2	11.50	T08	11.50	15.30		●
MM HRF160-2T10	16.00	2	15.80	T10	15.20	19.10		●

- For shanks, see pages 79-86
- For clamping keys (to be ordered separately), tightening torques and clamping instructions, see pages 10-11
- Do not apply lubricant to the threaded connection.
- For user guide, see pages 9,12-13

⁽¹⁾ Cutting diameter maximum
⁽²⁾ Number of flutes

MULTI-MASTER
INDEXABLE SOLID CARBIDE LINE

MM HBR
Interchangeable 2 Flute High Precision Ball Nose Solid Carbide Milling Heads

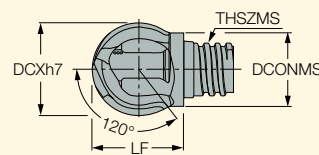

ECONOMICAL SOLUTION

Designation	Dimensions						IC908
	DCX ⁽¹⁾	NOF ⁽²⁾	THSZMS	DCONMS	LF		
MM HBR080-2T04	8.00	2	T04	5.80	8.22	MM KEY 6X4*	●
MM HBR100-2T05	10.00	2	T05	7.60	10.00	MM KEY 6X4*	●
MM HBR120-2T06	12.00	2	T06	9.50	11.60	MM KEY 10X7*	●
MM HBR160-2T08	16.00	2	T08	12.20	15.40	MM KEY 13X8*	●
MM HBR200-2T10	20.00	2	T10	15.20	18.40	MM KEY 13X8*	●
MM HBR250-2T12	25.00	2	T12	18.30	23.20	MM KEY 16X9*	●

- For shanks, see pages 79-86
- For tightening torques and clamping instructions, see pages 10-11
- Do not apply lubricant to the threaded connection.

• For user guide, see pages 9,12-13

⁽¹⁾ Cutting diameter maximum
⁽²⁾ Number of flutes

* Optional, to be ordered separately

MM EB
Interchangeable Solid Carbide
Ball Nose Milling Heads

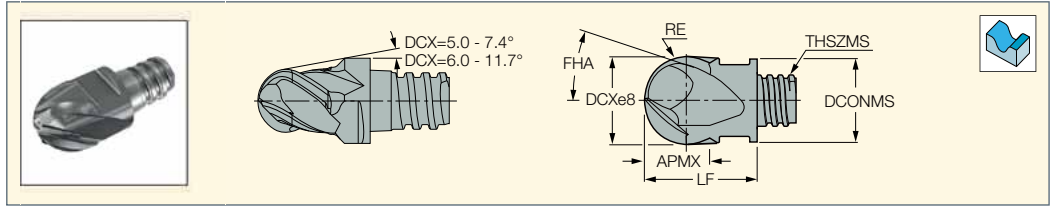

Designation	Dimensions								IC908
	DCX ⁽²⁾	NOF ⁽³⁾	APMX	RE	THSZMS	DCONMS	LF	FHA	
MM EB050E07-4T05	5.00	4	7.00	2.49	T05	8.00	15.00	38.0	●
MM EB060E04-4T04	6.00	4	4.00	2.99	T04	5.80	7.60	37.0	●
MM EB060E05-4T05	6.00	4	5.00	2.99	T05	8.00	10.00	38.0	●
MM EB080A05-2T05	8.00	2	5.00	3.98	T05	7.70	10.00	30.0	●
MM EB080A05-4T05	8.00	4	5.00	3.98	T05	7.70	10.00	30.0	●
MM EB100A07-2T06	10.00	2	7.00	4.98	T06	9.60	13.00	30.0	●
MM EB100A07-4T06	10.00	4	7.00	4.98	T06	9.60	13.00	30.0	●
MM EB120A09-2T08	12.00	2	9.00	5.98	T08	11.70	16.50	30.0	●
MM EB120H09CF-3T08 ⁽¹⁾	12.00	3	9.00	5.98	T08	11.70	16.50	38.0	●
MM EB120A09-4T08	12.00	4	9.00	5.98	T08	11.70	16.50	30.0	●
MM EB160A09-2T10	16.00	2	9.00	7.98	T10	15.30	20.50	30.0	●
MM EB160A12-4T10	16.00	4	12.00	7.98	T10	15.30	20.50	30.0	●
MM EB200A15-4T12	20.00	4	15.00	9.97	T12	18.45	25.50	30.0	●
MM EB250A22-4T15	25.00	4	22.00	12.47	T15	23.90	37.00	30.0	●

- For shanks, see pages 79-86
- For clamping keys (to be ordered separately), tightening torques and clamping instructions, see pages 10-11
- Do not apply lubricant to the threaded connection.
- For user guide, see pages 9,12-13

⁽¹⁾ With coolant holes directed to each flute
⁽²⁾ Cutting diameter maximum
⁽³⁾ Number of flutes

MM HT
Toroidal 2 Flute Interchangeable
Solid Carbide Milling Heads

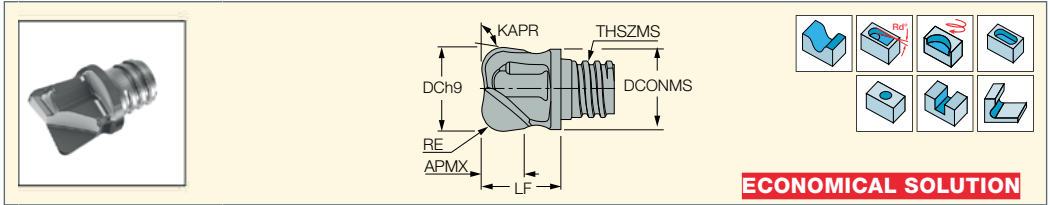

Designation	Dimensions									Tough ↔ Hard	
	DC	NOF ⁽¹⁾	APMX	RE	Tm ⁽²⁾	THSZMS	DCONMS	LF	KAPR ⁽³⁾	IC908	IC903
MM HT100C08R0.5-2T06	10.00	2	7.00	0.50	r0-1.0	T06	9.50	12.45	95.0	●	
MM HT100C08R1.0-2T06	10.00	2	7.00	1.00	r0-1.0	T06	9.50	12.45	95.0	●	
MM HT100N06R2.0-2T06	10.00	2	6.00	2.00	r0-3.0	T06	9.50	12.40	97.0	●	
MM HT100N07R0.5-2T06	10.00	2	6.90	0.50	r0-1.0	T06	9.50	11.20	95.0		●
MM HT100N07R1.0-2T06	10.00	2	6.90	1.00	r0-1.0	T06	9.50	11.20	95.0		●
MM HT100N07R2.0-2T06	10.00	2	6.90	2.00	r0-3.0	T06	9.50	11.20	95.0		●
MM HT100N07R3.0-2T06	10.00	2	6.90	3.00	r2.7-4.0	T06	9.50	11.20	95.0		●
MM HT120N06R3.0-2T06	12.00	2	5.40	3.00	r2.7-4.0	T06	9.10	9.10	97.0	●	
MM HT120N06R4.0-2T06	12.00	2	5.10	4.00	r2.7-4.0	T06	11.50	9.10	97.0	●	
MM HT120N06R1.6-2T08	12.00	2	5.70	1.60	r1.3-r2.7	T08	11.50	11.10	97.0	●	●
MM HT120N06R2.0-2T08	12.00	2	5.90	2.00	r1.3-2.7	T08	11.50	11.10	97.0	●	●
MM HT120N06R2.5-2T08	12.00	2	5.50	2.50	r1.3-4.0	T08	11.50	11.10	97.0	●	●
MM HT120N06R3.0-2T08	12.00	2	5.50	3.00	r2.7-4.4	T08	11.50	11.10	97.0	●	●
MM HT120N06R4.0-2T08	12.00	2	5.60	4.00	r2.7-4.4	T08	11.50	11.10	97.0	●	●
MM HT160N07R2.0-2T10	16.00	2	6.90	2.00	r1.5-4.0	T10	15.20	13.10	97.0	●	●
MM HT160N07R3.0-2T10	16.00	2	7.20	3.00	r1.5-4.0	T10	15.20	13.40	97.0	●	●
MM HT160N07R4.0-2T10	16.00	2	7.10	4.00	r1.5-4.0	T10	15.20	13.40	97.0	●	●
MM HT160N08R5.0-2T10	16.00	2	8.00	5.00	r2.7-4.4	T10	15.20	20.20	97.0	●	●
MM HT200N11R3.0-2T12	20.00	2	10.80	3.00	r3.0-8.0	T12	18.45	17.00	97.0	●	●
MM HT200N11R4.0-2T12	20.00	2	11.10	4.00	r3.0-8.0	T12	18.45	17.30	97.0	●	●
MM HT200N11R5.0-2T12	20.00	2	11.10	5.00	r3.0-8.0	T12	18.45	17.30	97.0	●	●
MM HT200N11R6.0-2T12	20.00	2	11.00	6.00	r3.0-8.0	T12	18.45	17.30	97.0	●	●
MM HT200N11R8.0-2T12	20.00	2	10.90	8.00	r3.0-8.0	T12	18.45	17.30	97.0	●	●

- For shanks, see pages 79-86
- For clamping keys (to be ordered separately), tightening torques and clamping instructions, see pages 10-11
- Do not apply lubricant to the threaded connection.
- For user guide, see pages 9,12-13

⁽¹⁾ Number of flutes
⁽²⁾ Specially tailored radius range upon request
⁽³⁾ Tool cutting edge angle

MULTI-MASTER
INDEXABLE SOLID CARBIDE LINE

MM ETR

Torodial 6 Flute Interchangeable Solid Carbide Milling Heads

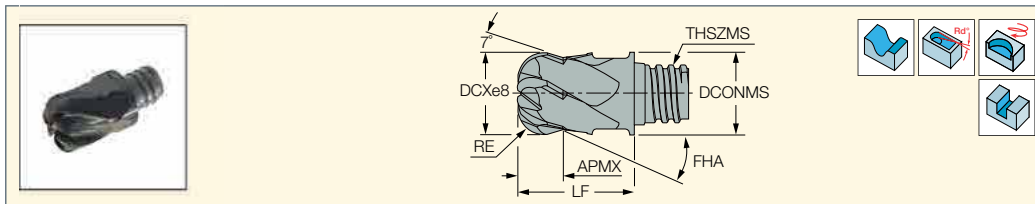

Designation	Dimensions									Tough ↔ Hard	
	DCX ⁽¹⁾	RE	NOF ⁽²⁾	APMX	THSZMS	DCONMS	LF	FHA	RMPX ⁽³⁾	IC908	IC903
MM ETR080A4R05CF-6T05	8.00	0.50	6	4.00	T05	7.70	10.00	30.0	9.0		●
MM ETR080A4R10CF-6T05	8.00	1.00	6	4.00	T05	7.70	10.00	30.0	9.0		●
MM ETR080A04R2.0-6T05	8.00	2.00	6	5.00	T05	7.70	10.00	30.0	9.0	●	
MM ETR100A5R05CF-6T06	10.00	0.50	6	5.00	T06	9.60	13.00	30.0	9.0		●
MM ETR100A5R10CF-6T06	10.00	1.00	6	5.00	T06	9.60	13.00	30.0	9.0		●
MM ETR100A05R3.0-6T06	10.00	3.00	6	7.00	T06	9.60	13.00	30.0	9.0	●	
MM ETR120A7R05CF-6T08	12.00	0.50	6	7.00	T08	12.00	17.00	30.0	9.0		●
MM ETR120A7R10CF-6T08	12.00	1.00	6	7.00	T08	11.70	16.50	30.0	9.0		●
MM ETR120A07R4.0-6T08	12.00	4.00	6	9.00	T08	11.70	16.50	30.0	9.0	●	
MM ETR160A09R5.0-6T10	16.00	5.00	6	12.00	T10	15.30	20.50	30.0	9.0	●	

• For shanks, see pages 79-86 • For clamping keys (to be ordered separately), tightening torques and clamping instructions, see pages 10-11

• Do not apply lubricant to the threaded connection. • For user guide, see pages 9,12-13

⁽¹⁾ Cutting diameter maximum

⁽²⁾ Number of flutes

⁽³⁾ Maximum ramping angle

MULTI-MASTER
INDEXABLE SOLID CARBIDE LINE

MM EBA

Interchangeable 2 Flute High Precision Solid Carbide Ball Nose Heads for Machining Aluminum

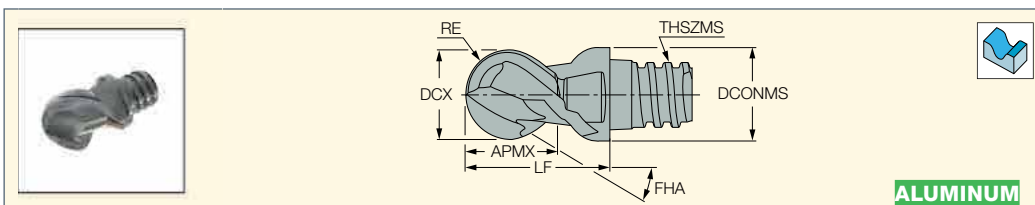

ALUMINUM

Designation	Dimensions									IC08
	DCX ⁽¹⁾	NOF ⁽²⁾	APMX	RE	RETOL ⁽³⁾	THSZMS	DCONMS	LF	FHA	
MM EBA080B05-2T05	8.00	2	5.00	3.98	0.010	T05	7.70	10.00	45.0	●
MM EBA100B07-2T06	10.00	2	7.00	4.98	0.010	T06	9.60	13.00	45.0	●
MM EBA120B09-2T08	12.00	2	9.00	5.98	0.012	T08	11.50	16.50	45.0	●
MM EBA160B12-2T10	16.00	2	12.00	7.98	0.012	T10	15.30	20.50	45.0	●
MM EBA200B15-2T12	20.00	2	15.00	9.97	0.012	T12	18.45	25.50	45.0	●
MM EBA250B22-2T15	25.00	2	22.00	12.50	0.012	T15	23.90	37.00	45.0	●

• For shanks, see pages 79-86 • For clamping keys (to be ordered separately), tightening torques and clamping instructions, see pages 10-11

• Do not apply lubricant to the threaded connection. • For user guide, see pages 9,12-13

⁽¹⁾ Cutting diameter maximum

⁽²⁾ Number of flutes

⁽³⁾ Corner radius tolerance (+/-)

MM EBC

Interchangeable Solid Carbide
Ball Nose Milling Heads for High
Productivity on Hard Materials

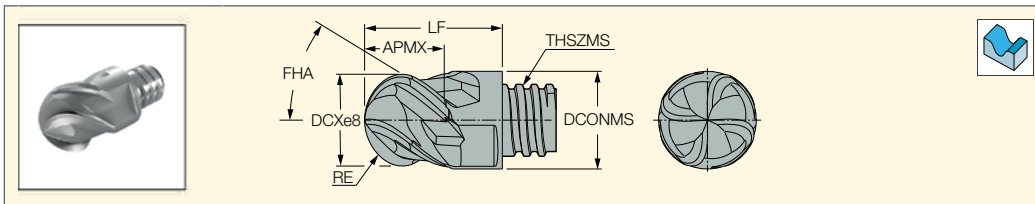

Designation	Dimensions								IC903
	DCX ⁽¹⁾	NOF ⁽²⁾	APMX	RE	THSZMS	DCONMS	LF	FHA	
MM EBC080B05-4T05CF	8.00	4	5.40	3.98	T05	7.70	10.00	45.0	●
MM EBC100B07-4T06CF	10.00	4	7.40	4.98	T06	9.60	13.00	45.0	●
MM EBC120B09-4T08CF	12.00	4	9.30	5.98	T08	11.70	16.50	45.0	●
MM EBC160B12-4T10CF	16.00	4	12.40	7.98	T10	15.30	20.50	45.0	●
MM EBC200B15-4T12CF	20.00	4	16.00	9.97	T12	18.45	25.50	45.0	●

• For shanks, see pages 79-86 • For clamping keys (to be ordered separately), tightening torques and clamping instructions, see pages 10-11

• Do not apply lubricant to the threaded connection. • For user guide, see pages 9,12-13

⁽¹⁾ Cutting diameter maximum

⁽²⁾ Number of flutes

* Optional, to be ordered separately

NEOBARREL
PROFILE MILLING

MM ELB

Interchangeable Lens
Shaped (Barrel) Solid Carbide
Heads for 3D Profiling

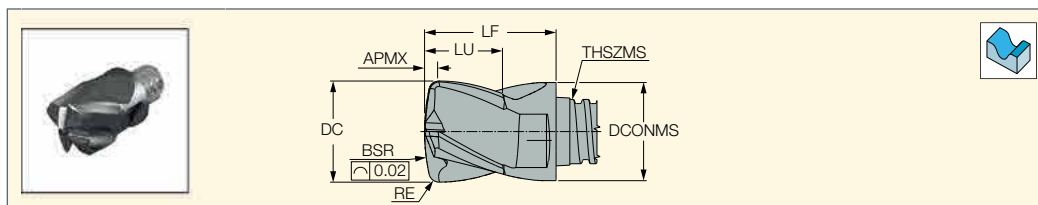

Designation	Dimensions									IC908
	DC	BSR	RE	LU	APMX	THSZMS	DCONMS	NOF ⁽¹⁾	LF	
MM ELB08R16A05-4T05	8.00	16.00	0.50	5.50	0.90	T05	8.00	4	10.00	●
MM ELB10R20A07-4T06	10.00	20.00	1.00	7.50	1.42	T06	10.00	4	13.00	●
MM ELB12R24A09-4T08	12.00	24.00	1.00	9.00	1.55	T08	12.00	4	16.50	●
MM ELB16R32A12-4T10	16.00	32.00	1.00	12.00	1.80	T10	16.00	4	20.50	●

• For user guide, see pages 9,12-13, 40-44

⁽¹⁾ Number of flutes

MULTI-MASTER
INDEXABLE SOLID CARBIDE LINE
NEOBARREL
PROFILE MILLING

MM EOB
Interchangeable Oval-Shaped (Barrel) Solid Carbide Heads for 3D Profiling

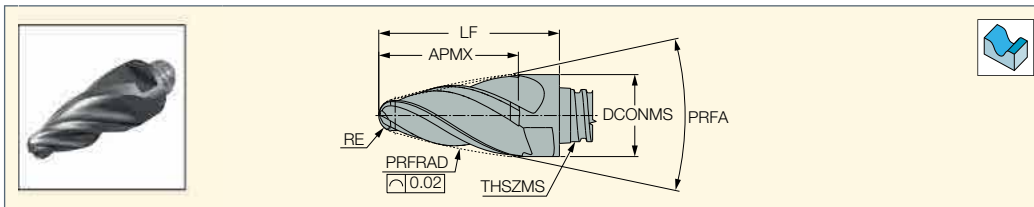

Designation	Dimensions								IC908
	PRFRAD	RE	APMX	PRFA	THSZMS	NOF ⁽¹⁾	DCONMS	LF	
MM EOB08R1.5R80A13-4T05	80.00	1.50	14.20	24.00	T05	4	8.00	18.00	●
MM EOB10R2.0R85A16-4T06	85.00	2.00	16.50	24.00	T06	4	10.00	22.00	●
MM EOB12R2.0R75A21-4T08	75.00	2.00	21.30	24.00	T08	4	12.00	27.00	●
MM EOB16R3.0R75A26-4T10	75.00	3.00	27.00	24.00	T10	4	16.00	33.40	●

• For user guide, see pages 9,12-13, 40-44
(1) Number of flutes

MULTI-MASTER
INDEXABLE SOLID CARBIDE LINE

MM ET
Solid Carbide Tapered Heads with 20/30° Helix, Variable Pitch and Coolant Holes for CHATTERFREE Finishing Operations

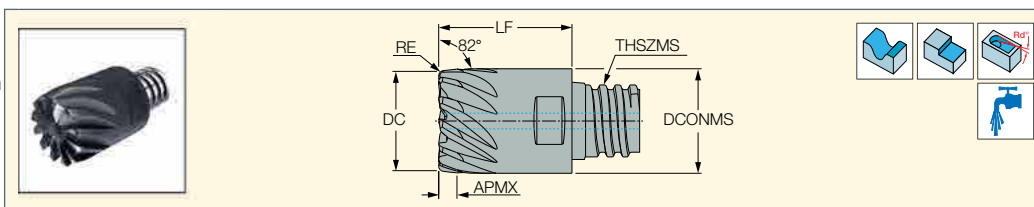

Designation	Dimensions								IC908	Recommended Machining Data
	DC	RE	NOF ⁽¹⁾	APMX	THSZMS	DCONMS	LF	RMPX ⁽²⁾		f _z (mm/t)
MM ET11/8H4R10CF-8T08H	11.00	1.00	8	3.50	T08	12.00	16.50	3.0	●	0.04-0.10
MM ET15/8H4R10CF-12T10H	15.00	1.00	12	3.50	T10	16.00	20.50	3.0	●	0.05-0.11

• For shanks, see pages 79-86 • For clamping keys (to be ordered separately), tightening torques and clamping instructions, see pages 10-11
• Do not apply lubricant to the threaded connection. • For user guide, see pages 9,12-13
(1) Number of flutes
(2) Maximum ramping angle



TORMILL

MULTI-MASTER

E93CN-MM-07

Bull Nose Endmills with
MULTI-MASTER Threaded
Adaptation Carrying
Toroidal Inserts

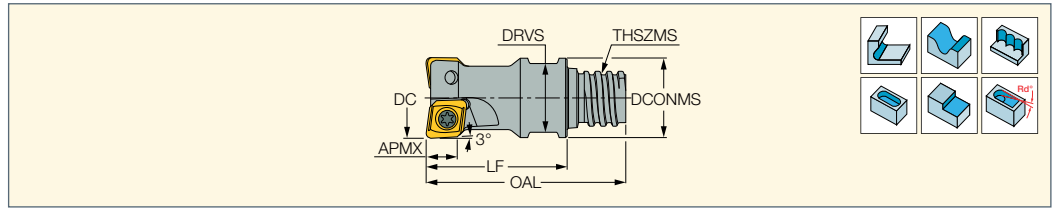

Designation	DC ⁽¹⁾	APMX	CICT ⁽²⁾	LF	OAL	RMPX ⁽³⁾	THSZMS	DCONMS	DRVS ⁽⁴⁾	MIID ⁽⁵⁾			
E93CN D16-2-MMT10-07	16.00	5.00	2	27.00	38.64	4.0	T10	15.00	13.0	CNHT 070315	0.03	SR 34-505/LHG	T-8/53
E93CN D20-3-MMT12-07	20.00	5.00	3	27.00	41.00	3.0	T12	19.00	16.0	CNHT 070315	0.05	SR 34-505/LHG	T-8/53

• Do not apply lubricant to the MULTI-MASTER threaded connection • For adaptation options, see page 9 • For user guide, see pages 10-11

⁽¹⁾ The specified diameter is for inserts with a 1.0 mm radius. For other radii options, see diameter change in the table below

⁽²⁾ Number of inserts

⁽³⁾ Maximum ramping angle

⁽⁴⁾ Clamping wrench size

⁽⁵⁾ Master insert identification

For inserts: CNHT/MT 07

For holders, see pages: MM S-A (stepped shanks) (79) • MM S-A (straight shanks) (82) • MM S-A-C# (85) • MM S-A-HSK (85)

• MM S-A-N (81) • MM S-A-SK (85) • MM S-B (85° conical shanks) (82) • MM S-D (89° conical shanks) (83) • MM S-ER (84) • MM S-ER-H (84) • MM TS-A (81)

Diameter Change According to Insert Radius

R	0.8	1.0	1.5	2.0	2.5	3.0
ΔD	+0.03	0.0	-0.07	-0.14	-0.21	-0.28



Circle Segment Lines for Advanced Finish Milling Operations

Barrel Endmill

ISCAR's Barrel line comprises a variety of solid carbide endmills and **MULTI-MASTER** heads in different shapes: Oval, Taper & Lens.

For more information, refer to **ISCAR'S** New Product Announcement 22-2020



Solid Carbide Endmills

- Oval Barrel - EOB
- Taper Barrel - ETB
- Lens Barrel - ELB

MULTI-MASTER Heads

- Oval Barrel - MM EOB
- Lens Barrel - MM ELB

Barrel endmills are intended for finishing and semi-finishing 3D surfaces

Blade Rough	Blade Finish
	

A prominent advantage of a Barrel endmill over a Ball-Nose is the number of stepovers. Therefore machining time can be significantly reduced without degradation of the surface finish parameters.

The large-diameter arc of the endmill cutting edge results in a substantial reduction of the cusp height.

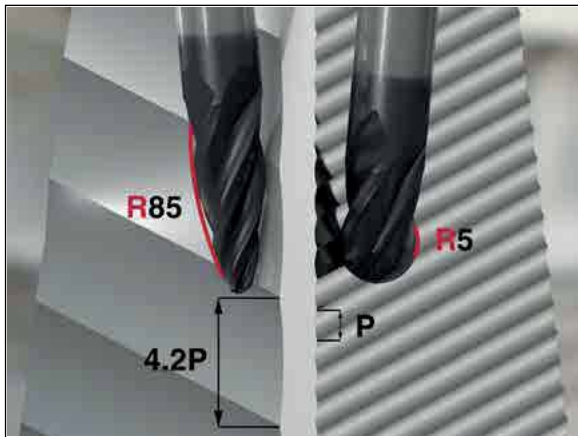

Machining Guidelines

The Most Important Thing to Remember

Programming circle segment tooling requires a supporting CAM system

- Step #1 – for Ball-Nose**

Select a Ball-Nose tool configuration and define its parameters.

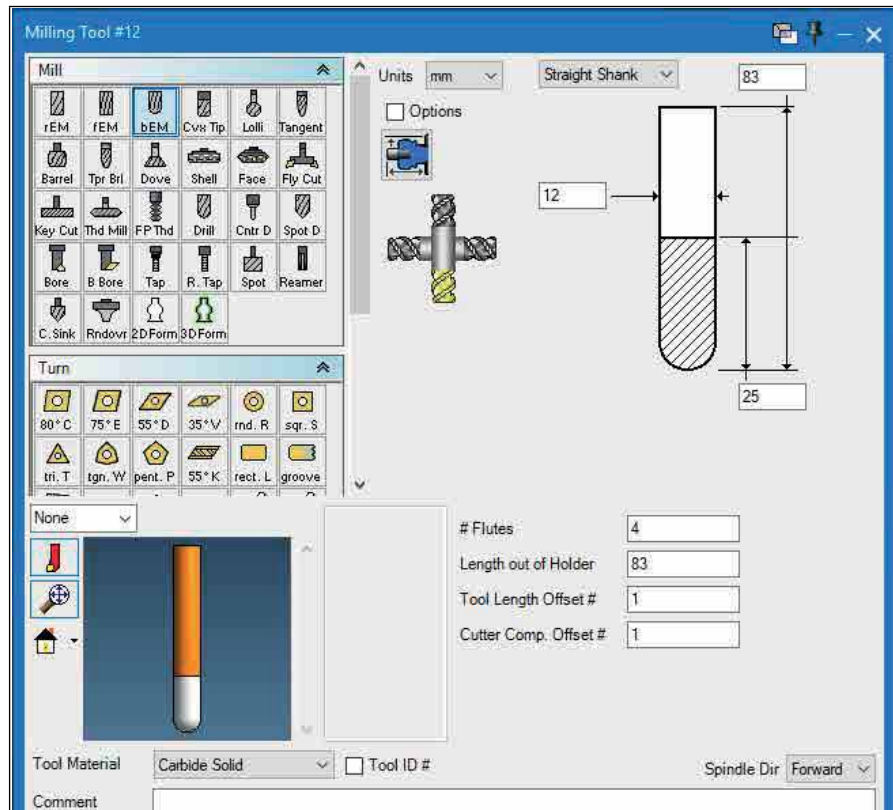

- Step #1 – for Oval Shape**

Select a Barrel tool configuration and define its parameters.

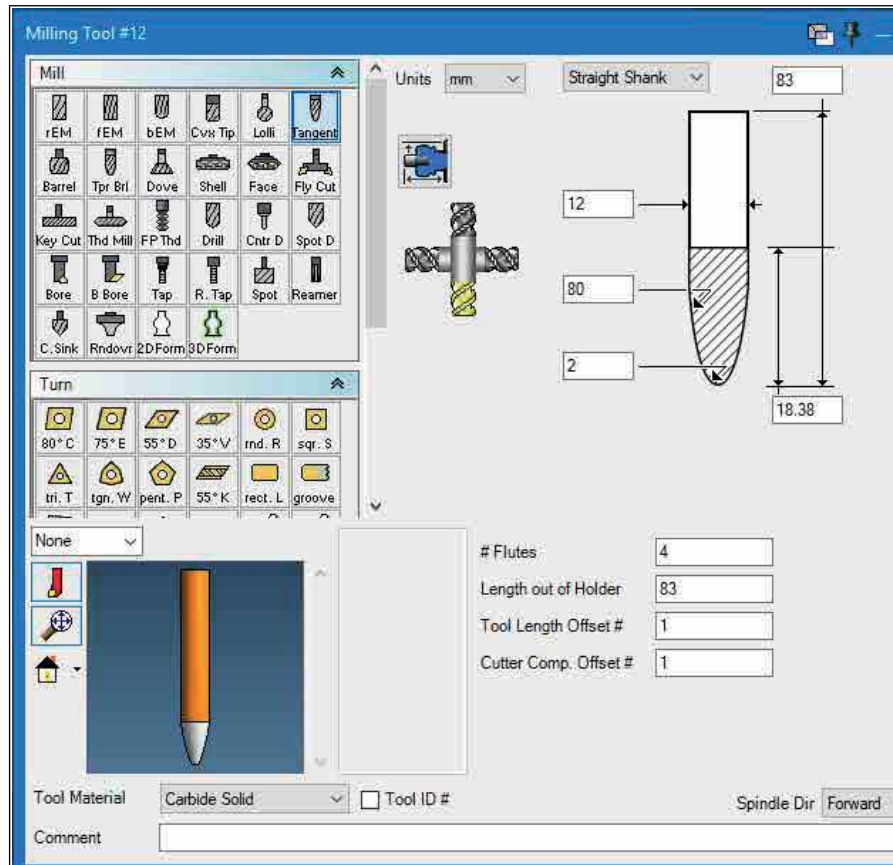

- **Step #1 – for Taper Shape**
Select a Taper tool configuration and set its parameters.

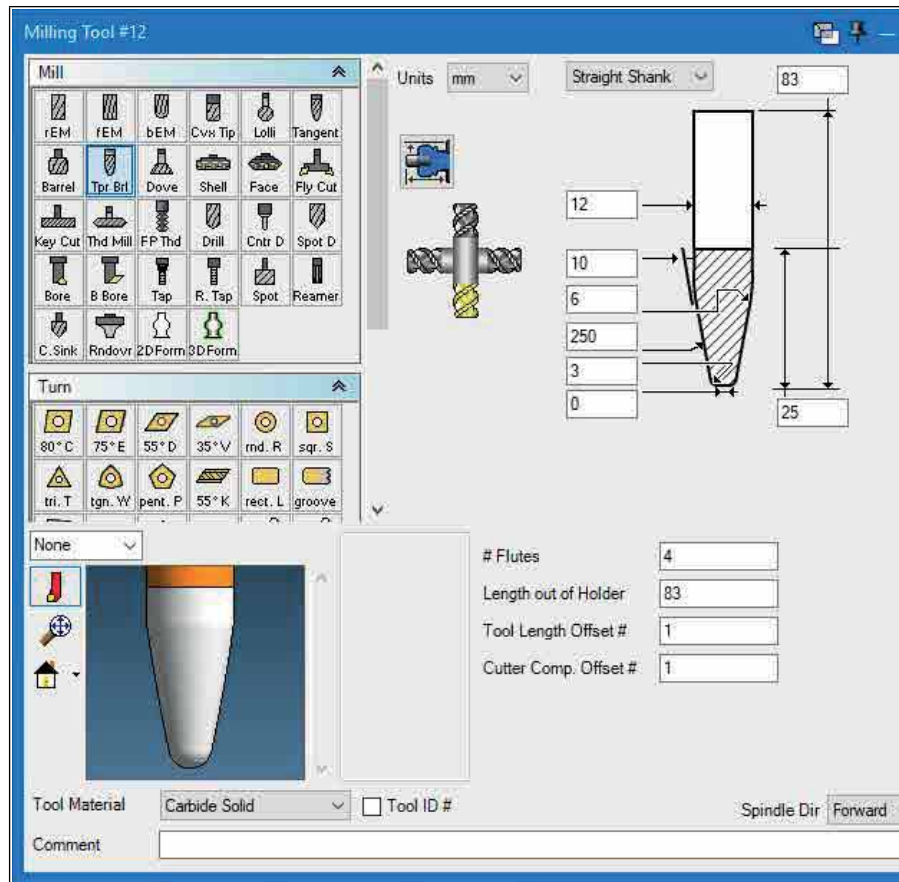

- **Step #1 – for Lens Shape**
Select a Lens tool configuration and set its parameters.

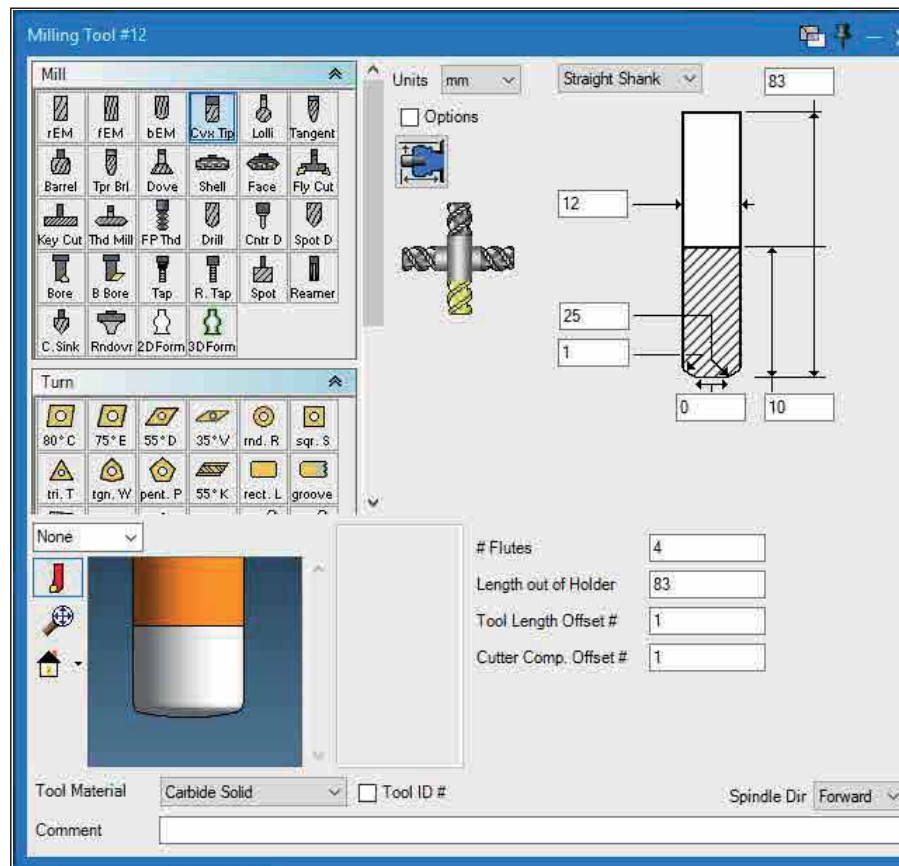

Step #2

Select the process. Each CAM defines different and relevant processes, for example:

Surface, 5-Axis, Adv3D, etc.

Remember:

The advantage of barrel endmills is realized when used for 5 axis, finish milling operations.

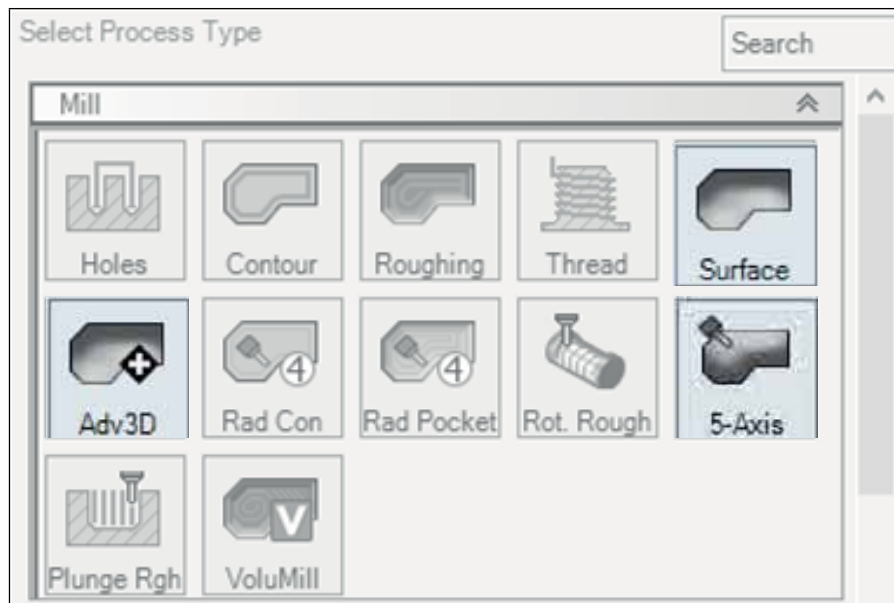

Important

Each CAM software has its own features to configure the tools and their machining processes, with similar definitions.

The following example demonstrates only one way to define surface finish (Ra) and is process dependent. In this example you will notice how many steppers are required to obtain the same Ra with different tools.

There are different options to define the required results from a tool.

Example

Same Ra – Different steppers

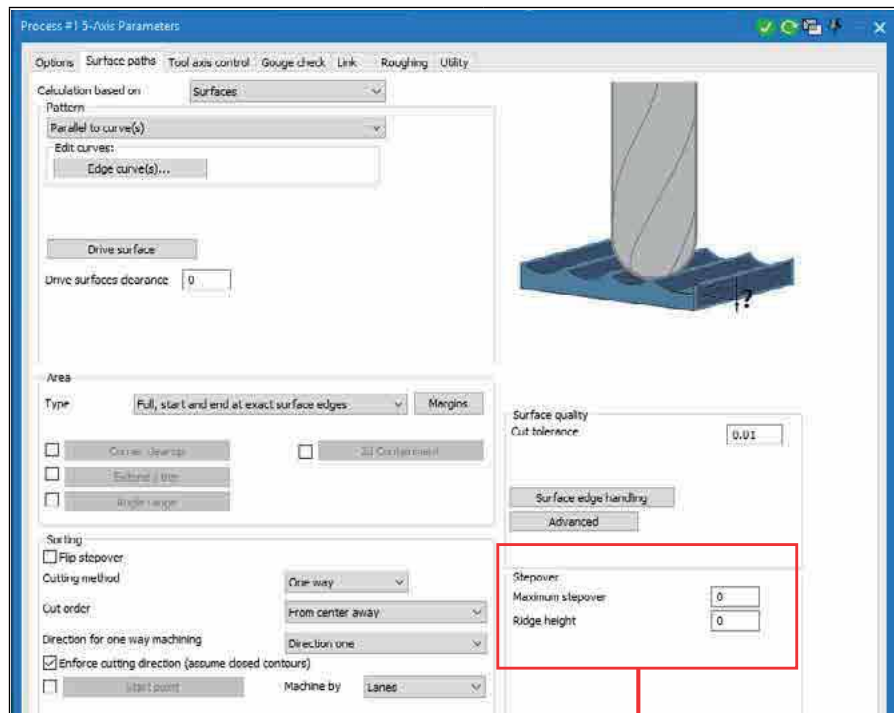

Ball Nose Ø12 R6 [Ø.472" R.236"]	Stepover Maximum stepover: 2
Oval Ø12 R80 [Ø.472" R3.15"]	Stepover Maximum stepover: 7.4
Taper Ø12 R250 [Ø.472" R9.84"]	Stepover Maximum stepover: 13.5
Lens Ø12 R25 [Ø.472" R.98"]	Stepover Maximum stepover: 4.09

To Be Considered

Barrel milling is not necessarily the answer to finishing 3D machined surfaces. Some part shapes are not conducive to Barrel milling operations. Sometimes, the blend radii of the machined part or the kinetics of the machine, result in a complicated CAM tool path which may increase the cycle time compared to using a conventional Ball-Nose milling approach. This is where the need for a highly skilled programmer to make good and effective decisions comes into play.

Recommended initial metric cutting parameters (for Barrel)

ISO	Material	Condition	Tensile Strength [N/mm ²]	Hardness HB	Material Group No.	Cutting Parameters			
						V _c m/min	f _z mm/t	f _z start	
P	non-alloy steel and cast steel, free cutting steel	<0.25% C	annealed	420	125	1	210-300	0.005-0.01xD	0.006xD
		≥0.25% C	annealed	650	190	2	200-250	0.005-0.01xD	0.006xD
		<0.55% C	quenched and tempered	850	250	3	160-240	0.004-0.009xD	0.005xD
		annealed	750	220	4	160-240	0.003-0.008xD	0.004xD	
		≥0.55% C	quenched and tempered	1000	300	5	140-200	0.004-0.009xD	0.005xD
		annealed	600	200	6	160-240	0.003-0.008xD	0.004xD	
	low alloy and cast steel (less than 5% of alloying elements)	quenched and tempered	930	275	7	120-200	0.003-0.008xD	0.004xD	
			1000	300	8	130-200	0.003-0.008xD	0.004xD	
			1200	350	9	140-200	0.003-0.008xD	0.004xD	
	high alloyed steel, cast steel and tool steel	annealed	680	200	10	130-200	0.003-0.008xD	0.004xD	
		quenched and tempered	1100	325	11	70-130	0.002-0.007xD	0.003xD	
	stainless steel and cast steel	ferritic / martensitic	680	200					12
			martensitic	820	240	13	60-165	0.002-0.007xD	0.003xD
Stainless steel and cast steel	Martensitic	820	240	13	60-165	0.002-0.007xD	0.003xD		
M	stainless steel and cast steel	austenitic, duplex	600	180	14	60-110	0.002-0.007xD	0.003xD	
K	gray cast iron (GG)	ferritic / pearlitic		180	15	150-275	0.005-0.01xD	0.006xD	
		pearlitic / martensitic		260	16	150-265	0.005-0.01xD	0.006xD	
	nodular cast iron (GGG)	ferritic		160	17	150-200	0.005-0.01xD	0.006xD	
		pearlitic		250	18	90-150	0.004-0.009xD	0.005xD	
	malleable cast iron	ferritic		130	19	150-200	0.005-0.01xD	0.006xD	
		pearlitic		230	20	90-150	0.004-0.009xD	0.005xD	
S	high temperature alloys	Fe based	annealed		200	31	20-45	0.002-0.004xD	0.003xD
			hardened		280	32	20-35	0.002-0.004xD	0.003xD
		Ni or Co based	annealed		250	33	20-35	0.002-0.004xD	0.003xD
			hardened		350	34	20-35	0.002-0.004xD	0.003xD
	titanium alloys	cast		320	35	60-90	0.002-0.004xD	0.003xD	
		pure	400	190	36	60-90	0.002-0.004xD	0.003xD	
H	hardened steel	alpha+beta alloys, hardened	1050	310	37	60-90	0.002-0.004xD	0.003xD	
		hardened		55 HRC	38	40-80	0.001-0.003xD	0.002xD	
		hardened		60 HRC	39				
	chilled cast iron	cast	400	40	40-80	0.001-0.003xD	0.002xD		
cast iron	hardened	55 HRC	41	40-80	0.001-0.003xD	0.002xD			

(1) Based on ISO 513 and VDI 3323 Standards

BALLPLUS MULTI-MASTER

HCM-MM

Ball Nose Multifunction
Endmills with a MULTI-MASTER
Threaded Adaptation

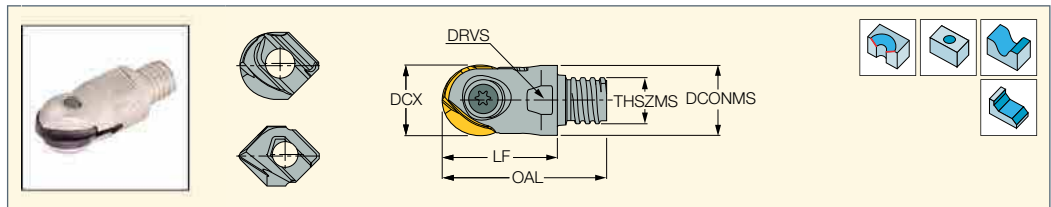

Designation	DCX ⁽¹⁾	OAL ⁽²⁾	LF ⁽³⁾	DCONMS	THSZMS	DRVS ⁽⁴⁾	TQ	TQ_3 ⁽⁵⁾				
HCM D12/.50-MMT08	12.00	28.00	20.00	11.50	T08	10.0	15.0	20	0.01	SR 34-540	BLD T15/S7	SW6-T
HCM D16/.62-MMT10	16.00	36.75	25.00	15.20	T10	13.0	28.0	33	0.03	SR 10503579	BLD T20/S7	SW6-T
HCM D20/.75-MMT12	20.00	48.80	35.00	18.50	T12	15.0	28.0	20	0.06	SR 1052964	BLD T25/S7	SW6-T
HCM D25/1.0-MMT15	25.00	63.00	46.00	24.00	T15	20.0	40.0	33	0.13	SR 1051666	BLD T25/S7	SW6-T

- The dimensions are for HBR inserts
- Do not apply lubricant to the MULTI-MASTER threaded connection
- For adaptation options, see page 9
- For user guide, see pages 10-11

⁽¹⁾ Cutting diameter maximum

⁽²⁾ Refers to HBR inserts

⁽³⁾ Refers to HBR inserts

⁽⁴⁾ Width across flats (wrench should be ordered separately)

⁽⁵⁾ Screw Tightening Torque

For inserts: HBF-QF • HBR-QF • HCC-QF • HCD-QF • HCR QF/QP • HCT-QF • HLB-QF

For holders, see pages: MM CAB (86) • MM GRT (shanks) (81) • MM S-A (stepped shanks) (79) • MM S-A (straight shanks) (82) • MM S-A-C# (85) • MM S-A-HSK (85)

• MM S-A-N (81) • MM S-A-SK (85) • MM S-B (85° conical shanks) (82) • MM S-D (89° conical shanks) (83) • MM S-ER (84) • MM S-ER-H (84) • MM TS-A (81)

DROPMILL MULTI-MASTER

BCM-MM

Ball Nose Endmills with
MULTI-MASTER Threaded Adaptation
that Mount Tangent Straight Edge
Inserts for Finish Profiling

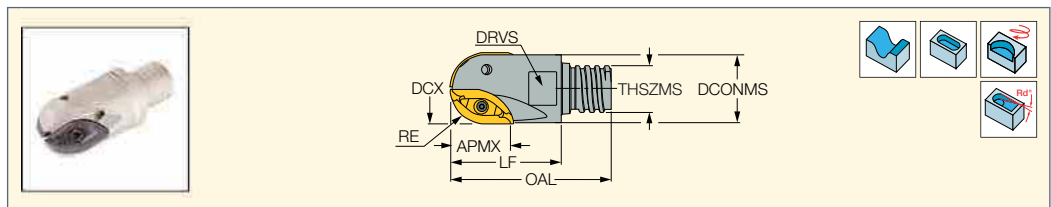

Designation	DCX ⁽²⁾	RE	APMX	CICT ⁽³⁾	LF	OAL	DRVS ⁽⁴⁾	DCONMS	THSZMS	CSP ⁽⁵⁾	MIID ⁽⁶⁾	
BCM D12-MMT08	12.00	6.00	9.60	2	20.00	28.00	10.0	11.50	T08	0	BCR D120-QT	0.01
BCM D16-MMT10	16.00	8.00	12.70	2	25.00	36.80	13.0	15.20	T10	0	BCR D160-QT	0.03
BCM D20-MMT12-CC ⁽¹⁾	20.00	10.00	17.00	2	35.00	48.80	15.0	18.50	T12	0	BCR D200..	0.10
BCM D25-MMT15-C	25.00	12.50	20.00	2	40.00	57.00	19.0	24.00	T15	1	BCR D250-QT	0.11

- Do not apply lubricant to the MULTI-MASTER threaded connection
- For adaptation options, see page 9
- For user guide, see pages 10-11

⁽¹⁾ Center Cutting

⁽²⁾ Cutting diameter maximum

⁽³⁾ Number of inserts

⁽⁴⁾ Clamping wrench size

⁽⁵⁾ 0 - Without coolant supply, 1 - With coolant supply

⁽⁶⁾ Master insert identification

For inserts: BCR

For holders, see pages: MM CAB (86) • MM S-A (stepped shanks) (79) • MM S-A (straight shanks) (82) • MM S-A-C# (85) • MM S-A-HSK (85) • MM S-A-N (81)

• MM S-A-SK (85) • MM S-B (85° conical shanks) (82) • MM S-D (89° conical shanks) (83) • MM S-ER (84) • MM S-ER-H (84) • MM TS-A (81)

Spare Parts

Designation				
BCM D12-MMT08	SR 10503457	T-6/51		
BCM D16-MMT10	SR 34-505/1 MHG 2.5X7.2	T-8/53		
BCM D20-MMT12	SR 34-506/L	T-9/51		
BCM D20-MMT12-CC	SR 34-506/L	T-9/51		
BCM D25-MMT15-C	SR 14-601		BLD T15/S7	SW6-T

Exchangeable Solid with Indexable Inserts

MULTI-MASTER
INDEXABLE SOLID CARBIDE LINE

MM HCD

Interchangeable 2 Flute Solid Carbide Heads for Chamfering, Countersinking and Spot Drilling

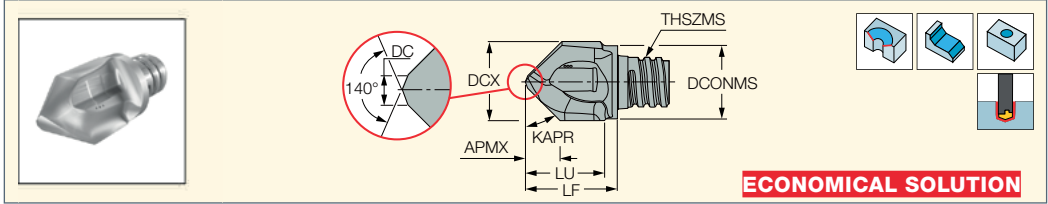

ECONOMICAL SOLUTION

Designation	Dimensions										IC908
	DCX ⁽⁴⁾	DCXTOL	NOF ⁽⁵⁾	LU	THSZMS	DCONMS	LF	APMX	DC	KAPR ⁽⁶⁾	
MM HCD080-120-2T05	8.00	h10	2	7.80	T05	7.60	10.30	2.15	1.00	30.0	●
MM HCD080-090-2T05 ⁽¹⁾	8.00	z9	2	7.00	T05	7.60	9.75	3.15	1.00	45.0	●
MM HCD083-090-2T05 ⁽¹⁾	8.30	z9	2	7.50	T05	7.60	10.00	3.56	1.00	45.0	●
MM HCD.375-080-2T06	9.50	z9	2	9.00	T06	9.20	11.80	5.00	2.00	50.0	●
MM HCD.375-100-2T06 ⁽²⁾	9.50	z9	2	9.70	T06	9.50	13.40	3.60	2.00	40.0	●
MM HCD100-060-2T06	10.00	h10	2	9.30	T06	9.50	11.75	7.60	1.50	60.0	●
MM HCD100-120-2T06	10.00	h10	2	9.50	T06	9.50	12.70	2.70	1.50	30.0	●
MM HCD100-090-2T06-N ⁽¹⁾	10.00	z9	2	10.10	T06	9.50	14.00	4.50	1.50	45.0	●
MM HCD104-090-2T06 ⁽¹⁾	10.40	z9	2	9.00	T06	9.50	11.75	4.60	1.50	45.0	●
MM HCD120-060-2T08	12.00	h10	2	11.00	T08	11.50	15.40	9.24	1.50	60.0	●
MM HCD120-120-2T08	12.00	h10	2	11.65	T08	11.50	15.20	3.50	1.50	30.0	●
MM HCD120-090-2T08 ⁽¹⁾	12.00	z9	2	12.00	T08	11.50	15.50	5.30	1.50	45.0	●
MM HCD124-090-2T08 ⁽¹⁾	12.40	z9	2	11.80	T08	11.50	15.50	5.50	1.50	45.0	●
MM HCD.500-080-2T08 ⁽³⁾	12.70	z9	2	11.10	T08	12.20	15.50	6.80	1.50	50.0	●
MM HCD.500-100-2T08 ⁽²⁾	12.70	z9	2	10.90	T08	11.50	14.70	4.90	1.50	40.0	●
MM HCD.625-080-2T10	15.90	z9	2	15.20	T10	15.00	18.80	8.80	2.00	50.0	●
MM HCD.625-100-2T10 ⁽²⁾	15.90	z9	2	14.90	T10	15.10	19.00	6.20	2.00	40.0	●
MM HCD160-060-2T10	16.00	h10	2	16.20	T10	15.20	20.20	12.00	2.50	60.0	●
MM HCD160-120-2T10	16.00	h10	2	15.50	T10	15.20	19.90	4.40	1.50	30.0	●
MM HCD160-090-2T10-N	16.00	z9	2	15.70	T10	15.20	20.00	7.40	1.50	45.0	●
MM HCD165-090-2T10 ⁽¹⁾	16.50	z9	2	14.90	T10	15.20	18.80	7.10	1.50	45.0	●
MM HCD.750-080-2T12	19.05	z9	2	19.60	T12	18.45	24.70	11.00	2.00	50.0	●
MM HCD.750-100-2T12 ⁽²⁾	19.05	z9	2	18.50	T12	18.30	23.60	7.50	1.50	40.0	●
MM HCD200-060-2T12	20.00	h10	2	18.20	T12	18.45	24.70	15.50	2.50	60.0	●
MM HCD200-120-2T12	20.00	h10	2	14.65	T12	18.45	21.15	5.50	1.50	30.0	●
MM HCD200-090-2T12 ⁽¹⁾	20.00	z9	2	18.20	T12	18.45	24.70	9.40	1.50	45.0	●

• For shanks, see pages 79-86 • Clamping keys (to be ordered separately), tightening torques and clamping instructions, see pages 10-11

• Do not apply lubricant to the threaded connection. • For user guide, see pages 9,12-13

⁽¹⁾ May be used for F-type (fine) countersink according to DIN 74.

⁽²⁾ May be used for 100° countersink according to ISO 5856, DIN EN 4072, ANSI B18.6.3-1972

⁽³⁾ Countersink according to American National and British standard flat screws.

⁽⁴⁾ Cutting diameter maximum

⁽⁵⁾ Number of flutes

⁽⁶⁾ Tool cutting edge angle

MM ECF

Interchangeable Solid Carbide Heads for Chamfering and Countersinking

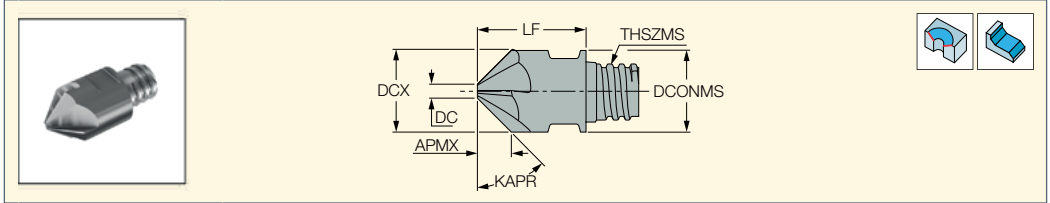

Designation	Dimensions								IC908
	KAPR ⁽¹⁾	DCX ⁽²⁾	NOF ⁽³⁾	DC	APMX	THSZMS	DCONMS	LF	
MM ECF120-02/100-4T06	30.0	10.00	4	2.00	2.30	T06	10.00	13.00	●
MM ECF120-02/120-4T08	30.0	12.00	4	2.00	2.90	T08	12.00	16.50	●
MM ECF120-03/160-6T10	30.0	16.00	6	3.00	3.70	T10	16.00	20.50	●
MM ECF120-05/200-6T12	30.0	20.00	6	5.00	4.30	T12	18.45	25.50	●
MM ECF120-06/250-6T15	30.0	25.00	6	6.00	5.40	T15	25.00	25.00	●
MM ECF45-080-4T05	45.0	8.00	4	1.95	3.00	T05	8.00	10.00	●
MM ECF45-100-4T06	45.0	10.00	4	1.95	4.00	T06	10.00	13.00	●
MM ECF45-120-4T08	45.0	12.00	4	1.95	5.00	T08	12.00	16.50	●
MM ECF45-150-4T08	45.0	12.70	4	1.95	5.00	T08	12.70	16.50	●
MM ECF45-160-6T10	45.0	16.00	6	3.00	6.50	T10	16.00	20.50	●
MM ECF45-200-6T12	45.0	20.00	6	5.00	7.50	T12	18.45	25.50	●
MM ECF45-250-6T15-M	45.0	25.00	6	5.00	10.00	T15	25.00	25.00	●
MM ECF60-100-4T06	60.0	10.00	4	1.60	7.30	T06	10.00	13.00	●
MM ECF60-02/100-4T06	60.0	10.00	4	2.00	6.90	T06	10.00	13.00	●
MM ECF60-03/120-4T08	60.0	12.00	4	3.00	7.80	T08	12.00	16.50	●
MM ECF60-04/160-6T10	60.0	16.00	6	4.00	10.00	T10	16.00	20.50	●
MM ECF60-05/200-6T12	60.0	20.00	6	5.00	13.00	T12	18.45	25.50	●
MM ECF60-08/250-6T15	60.0	25.00	6	8.00	14.00	T15	25.00	25.00	●

- For shanks, see pages 79-86
- For Clamping keys (to be ordered separately), tightening torques and clamping instructions, see pages 10-11
- Do not apply lubricant to the threaded connection.
- For user guide, see pages 9,12-13

- ⁽¹⁾ Tool cutting edge angle
- ⁽²⁾ Cutting diameter maximum
- ⁽³⁾ Number of flutes

MM HDF

Interchangeable 2 Flute Solid Carbide Heads for Upper and Bottom Chamfering

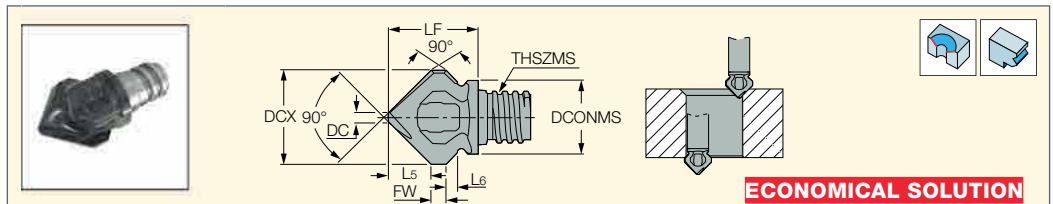

Designation	Dimensions										IC908
	DCX ⁽¹⁾	NOF ⁽²⁾	L5	L6	FW	DC	THSZMS	DCONMS	LF		
MM HDF100-090-2T05	9.80	2	4.30	0.90	2.50	1.20	T05	7.60	10.80	MM KEY 8X5*	●
MM HDF120-090-2T06	11.80	2	5.30	1.20	2.00	1.20	T06	9.30	11.20	MM KEY 10X7*	●
MM HDF160-090-2T08	15.70	2	7.10	2.20	2.00	1.50	T08	11.50	14.00	MM KEY 13X8*	●

- For shanks, see pages 79-86
- Clamping keys to be ordered separately
- For tightening torques and clamping instructions, see pages 10-11
- Do not apply lubricant to the threaded connection
- For user guide, see pages 9,12-13

- ⁽¹⁾ Cutting diameter maximum
- ⁽²⁾ Number of flutes

* Optional, to be ordered separately

MULTI-MASTER
INDEXABLE SOLID CARBIDE LINE

MM EDF

Interchangeable 3 Flute Solid Carbide Heads for Upper and Bottom Chamfering

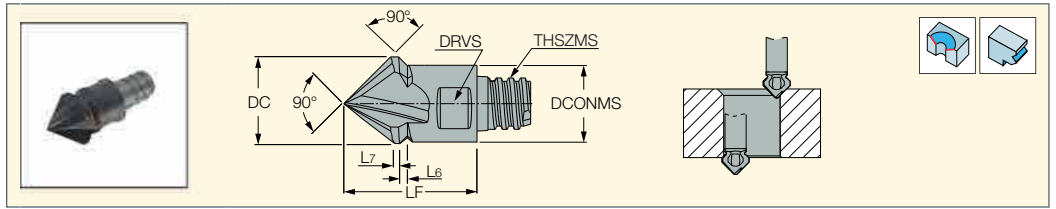

Dimensions								IC908
Designation	DC	DCONMS	NOF ⁽¹⁾	L6	L7	LF	THSZMS	
MM EDF074-090-58-3T04	7.40	5.80	3	0.90	1.00	10.00	T04	●
MM EDF094-090-76-3T05	9.40	7.60	3	0.90	1.00	12.50	T05	●
MM EDF116-090-95-3T06	11.60	9.60	3	1.00	1.00	16.50	T06	●

- For shanks, see pages 79-86 • For Clamping keys (to be ordered separately), tightening torques and clamping instructions, see pages 10-11
- Do not apply lubricant to the threaded connection. • For user guide, see pages 9,12-13

⁽¹⁾ Number of flutes

MULTI-MASTER
INDEXABLE SOLID CARBIDE LINE

MM TS-45

Interchangeable Solid Carbide Small Diameter 45° Chamfering Heads

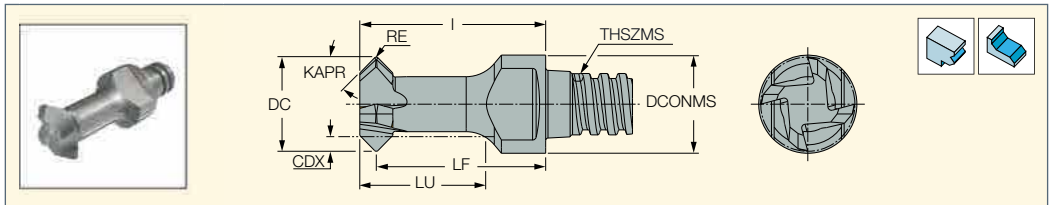

Dimensions										IC908	
Designation	DC	KAPR ⁽¹⁾	CDX ⁽²⁾	RE	NOF ⁽³⁾	I	THSZMS	DCONMS	LU		LF
MM TS077-45-20A-4T05	7.70	45.0	1.20	0.20	4	15.20	T05	8.00	10.3	13.85	●

- For clamping keys (to be ordered separately), tightening torques and clamping instructions, see pages 10-11 • Do not apply lubricant to the threaded connection

⁽¹⁾ Tool cutting edge angle

⁽²⁾ Cutting depth maximum

⁽³⁾ Number of flutes

MULTI-MASTER
INDEXABLE SOLID CARBIDE LINE

MM GRIT-45A

Interchangeable Solid Carbide Small Diameter 45° Chamfering Heads

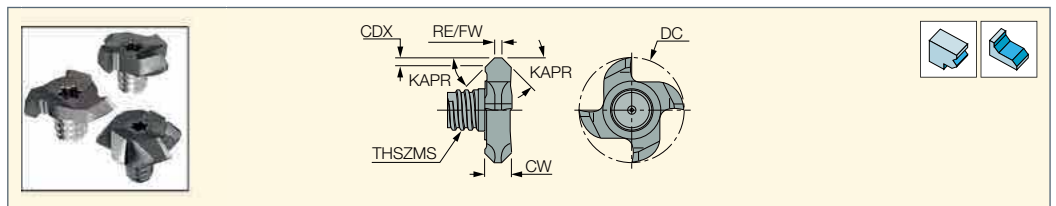

Dimensions										IC908
Designation	DC	KAPR ⁽¹⁾	CDX ⁽²⁾	RE	FW	CW	THSZMS	NOF ⁽³⁾	∠	
MM GRIT18K-45A-3T6	17.70	45.0	1.40	0.10	-	3.47	T06	3	T-25/3*	●
MM GRIT18P-45A-3T6	17.70	45.0	1.40	0.10	-	3.47	T06	3	T-25/3*	●
MM GRIT22K-45A-4T8	21.70	45.0	1.70	-	1.50	5.55	T08	4	T-30/3 L*	●
MM GRIT28K-45A-6T10	27.70	45.0	4.00	-	0.50	9.80	T10	6	T-40/3 L*	●

- P-TYPE - Positive geometry for soft and gummy materials. • K-Type - For general steel machining. • Modification options on request.

- Do not apply lubricant to the threaded connection. • For clamping instructions, see pages 10-11 • For shanks, see pages 79-86

⁽¹⁾ Tool cutting edge angle

⁽²⁾ Cutting depth maximum

⁽³⁾ Number of flutes

* Optional, to be ordered separately

MM ER

Interchangeable 4 Flute
Solid Carbide Corner
Round Milling Heads

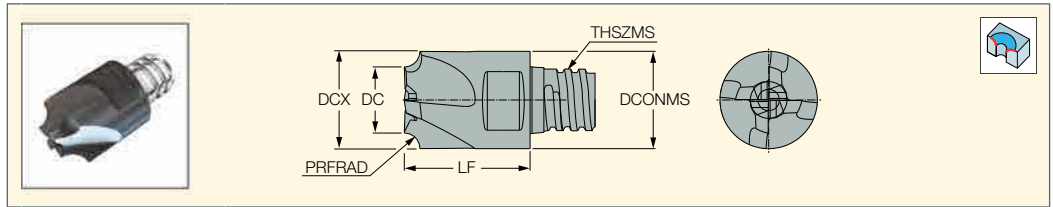

Designation	Dimensions								IC908
	PRFRAD	Tm ⁽¹⁾	DC	DCX ⁽²⁾	DCONMS	NOF ⁽³⁾	LF	THSZMS	
MM ER0.5/020-5.0-4T04	0.50	0.5-1.0	5.00	6.00	6.00	4	8.50	T04	●
MM ER1.0/040-5.8-4T05	1.00	0.5-1.4	5.80	8.00	8.00	4	10.00	T05	●
MM ER1.6/063-6.8-4T06	1.60	0.5-2.5	6.80	10.00	10.00	4	13.00	T06	●
MM ER2.0/078-6.0-4T06	2.00	0.5-2.5	6.00	10.00	10.00	4	13.00	T06	●
MM ER2.5/094-5.1-4T06	2.50	0.5-2.5	5.10	10.00	10.00	4	13.00	T06	●
MM ER3.0/125-6.5-4T08	3.00	0.5-3.1	6.50	12.70	12.70	4	16.50	T08	●

- For shanks, see pages 79-86
- For Clamping keys (to be ordered separately), tightening torques and clamping instructions, see pages 10-11
- Do not apply lubricant to the threaded connection.
- For user guide, see pages 9,12-13
- ⁽¹⁾ Specially tailored radius range upon request.
- ⁽²⁾ Cutting diameter maximum
- ⁽³⁾ Number of flutes

MM GRIT Dovetail
Interchangeable Solid
Carbide Heads

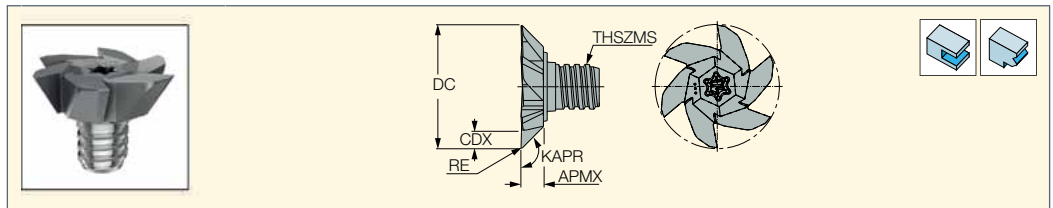

Designation	Dimensions								IC908
	DC	KAPR ⁽¹⁾	CDX ⁽²⁾	APMX	RE	THSZMS	NOF ⁽³⁾	∠	
MM GRIT 28K-45D-6T10	27.70	135.0	4.00	5.00	0.20	T10	6	T-40/3 L*	●
MM GRIT 28K-60D-6T10	27.70	120.0	4.00	7.80	0.20	T10	6	T-40/3 L*	●
MM GRIT 28K-75D-6T10	27.70	105.0	2.20	10.10	0.20	T10	6	T-40/3 L*	●

- Use carbide shanks for groove milling heads
- For user guide, see pages 9,12-13
- ⁽¹⁾ Tool cutting edge angle
- ⁽²⁾ Cutting depth maximum
- ⁽³⁾ Number of flutes
- * Optional, to be ordered separately



MM GRIT 28K-45D-6T10



MM GRIT 28K-60D-6T10

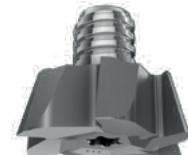

MM GRIT 28K-75D-6T10

MULTI-MASTER
INDEXABLE SOLID CARBIDE LINE

MM HR
Interchangeable 2 Flute
Solid Carbide Corner
Round Milling Heads

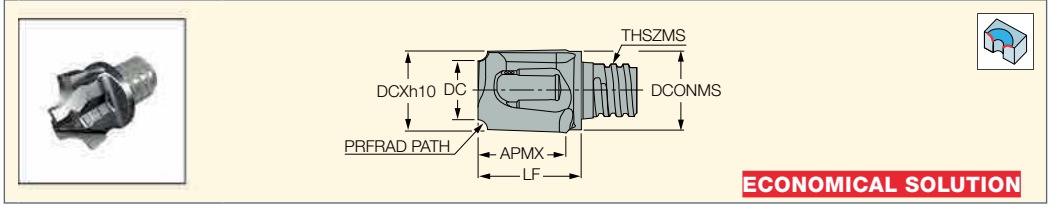

ECONOMICAL SOLUTION

Designation	Dimensions										IC908
	DCX ⁽¹⁾	PRFRAD	Tm ⁽²⁾	NOF ⁽³⁾	DC	APMX	THSZMS	DCONMS	LF		
MM HR1.0/047-5.8-2T05	8.00	1.00	r0.5-3.0	2	5.80	7.50	T05	7.60	10.60	●	
MM HR1.6/063-6.8-2T06	10.00	1.60	r0.5-3.0	2	6.80	9.50	T06	9.50	12.50	●	
MM HR2.0/078-6.0-2T06	10.00	2.00	r0.5-3.0	2	6.00	9.50	T06	9.50	12.50	●	
MM HR2.5/094-5.1-2T06	10.00	2.50	r0.5-3.0	2	5.10	9.50	T06	9.50	12.50	●	
MM HR3.0/125-6.5-2T08	12.70	3.00	r0.5-4.0	2	6.50	12.00	T08	11.50	15.60	●	
MM HR4.0/156-4.7-2T08	12.70	4.00	r0.5-4.0	2	4.70	12.00	T08	11.50	15.60	●	
MM HR5.0/188-6.2-2T10	16.00	4.88	r0.5-5.0	2	6.20	15.00	T10	15.20	19.10	●	
MM HR6.0/236-8.0-2T12	20.00	6.00	r0.5-6.0	2	8.00	7.00	T12	18.45	17.40	●	

- For shanks, see pages 79-86
- For Clamping keys (to be ordered separately), tightening torques and clamping instructions, see pages 10-11
- Do not apply lubricant to the threaded connection.
- For user guide, see pages 9,12-13

⁽¹⁾ Cutting diameter maximum
⁽²⁾ Specially tailored radius range upon request.
⁽³⁾ Number of flutes

MULTI-MASTER
INDEXABLE SOLID CARBIDE LINE

MM GRIT 28P-DR
Interchangeable 6 Flute Solid
Carbide Double-Sided Corner
Round Milling Heads

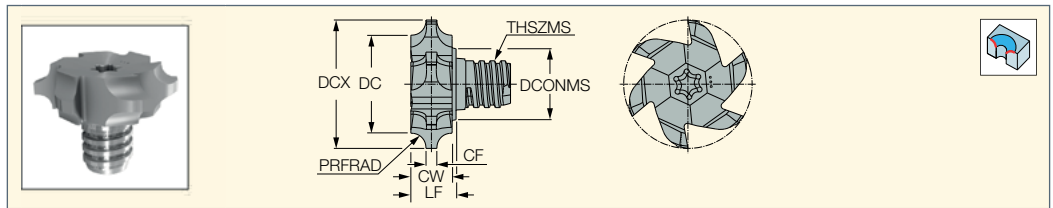

Designation	Dimensions										IC908
	PRFRAD	CF	DCX ⁽¹⁾	DC	LF	CW	NOF ⁽²⁾	THSZMS	DCONMS	↙	
MM GRIT 28P-2.7-DR1.0	1.00	2.70	27.70	24.80	6.00	5.60	6	T10	15.30	T-40/3 L*	●
MM GRIT 28P-2.6-DR2.0	2.00	2.60	27.70	22.90	7.70	7.30	6	T10	15.30	T-40/3 L*	●
MM GRIT 28P-2.3-DR3.0	3.00	2.30	27.70	21.10	9.70	8.90	6	T10	15.30	T-40/3 L*	●
MM GRIT 28P-2.6-DR4.0	4.00	2.60	27.70	19.70	11.70	10.90	6	T10	15.30	T-40/3 L*	●

- For shanks, see pages 79-86
- For Clamping keys (to be ordered separately), tightening torques and clamping instructions, see pages 10-11
- Do not apply lubricant to the threaded connection.
- For user guide, see pages 9,12-13

⁽¹⁾ Cutting diameter maximum
⁽²⁾ Number of flutes
 * Optional, to be ordered separately

CHAMF MILL
CHAMFERING LINE
MULTI-MASTER

CH45-MM-PN06
Upper and Bottom Chamfering
Endmills with a MULTI-MASTER
Threaded Adaptation

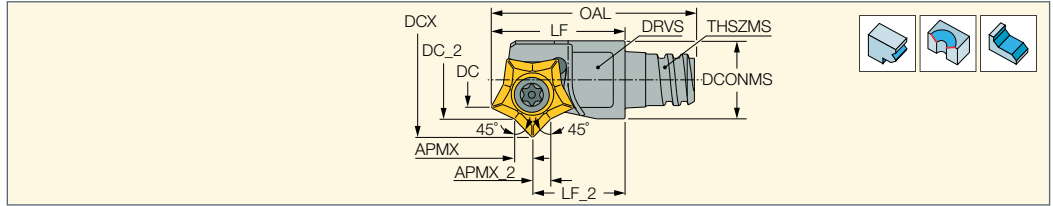

Designation	DCX ⁽¹⁾	DC_2	DC	APMX	APMX_2	LF	LF_2	OAL	DCONMS	THSZMS	CICT ⁽²⁾	DRVS ⁽³⁾	DMIN ⁽⁴⁾	kg
CH45-10/.39-1-MMT05-PN06	11.70	8.45	6.60	1.50	1.50	13.00	9.00	19.75	7.60	T05	1	5.5	10.00	0.03
CH45-17/.67-2-MMT08-PN06	16.70	13.45	11.40	1.50	1.50	18.00	14.00	25.50	12.20	T08	2	10.0	17.00	0.02
CH45-19/.75-3-MMT10-PN06	18.70	15.45	13.40	1.50	1.50	20.00	16.00	31.30	15.30	T10	3	13.0	19.00	0.02

• Do not apply lubricant to the MULTI-MASTER threaded connection • For adaptation options, see page 9 • For user guide, see pages 10-11

⁽¹⁾ Cutting diameter maximum

⁽²⁾ Number of inserts

⁽³⁾ Width across flats (wrench should be ordered separately)

⁽⁴⁾ Minimum penetration diameter for back chamfering



For inserts: PNMT 0602-TN

For holders, see pages: MM CAB (86) • MM CAB-T-T (86) • MM CAB-T-T-W (86) • MM GRT (shanks) (81) • MM S-A (stepped shanks) (79)

• MM S-A (straight shanks) (82) • MM S-A-C# (85) • MM S-A-HSK (85) • MM S-A-N (81) • MM S-A-SK (85) • MM S-B (85° conical shanks) (82)

• MM S-D (89° conical shanks) (83) • MM S-ER (84) • MM S-ER-H (84) • MM TS-A (81)

Spare Parts

Designation		
CH45-MM-PN06	SR M2.5X5-T7-60	T-7/51



Exchangeable Heads With Indexable Inserts

MULTI-MASTER
INDEXABLE SOLID CARBIDE LINE

MM EPG
Single Flute MULTI-MASTER
Engraving Tool Head

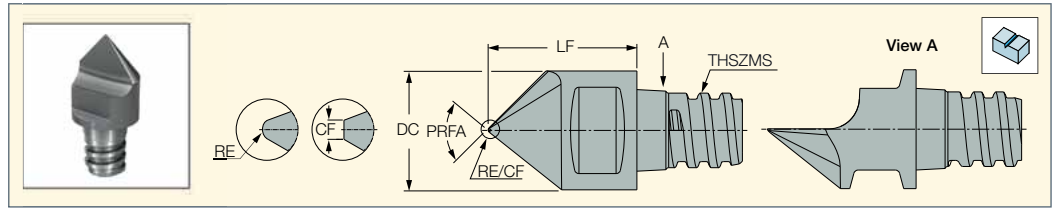

Designation	Dimensions						IC908
	DC	RE	CF ⁽¹⁾	PRFA	LF	THSZMS	
MM EPG060/60-1T04	6.00	0.20	-	60.00	8.50	T04	●
MM EPG080/30-1T05	8.00	0.20	-	30.00	10.00	T05	●
MM EPG080/45-1T05	8.00	0.20	-	45.00	10.00	T05	●
MM EPG080/60-1T05	8.00	0.20	-	60.00	10.00	T05	●
MM EPG080/90-1T05	8.00	0.20	-	90.00	10.00	T05	●
MM EPG080/60-F50-1T05	8.00	-	0.50	60.00	10.00	T05	●
MM EPG080/60-F75-1T05	8.00	-	0.75	60.00	10.00	T05	●
MM EPG080/90-F32-1T05	8.00	-	0.32	90.00	10.00	T05	●
MM EPG080/90-F50-1T05	8.00	-	0.50	90.00	10.00	T05	●

- For shanks, see pages 79-86
- For clamping keys (to be ordered separately), tightening torques and clamping instructions, see pages 10-11
- Do not apply lubricant to the threaded connection
- ⁽¹⁾ Front flat



HOLE MAKING



Exchangeable Solid Carbide Heads

SOLIDDRILL
MULTI-MASTER

MM ECS
Interchangeable Solid Carbide
Centering Drills (DIN 332)

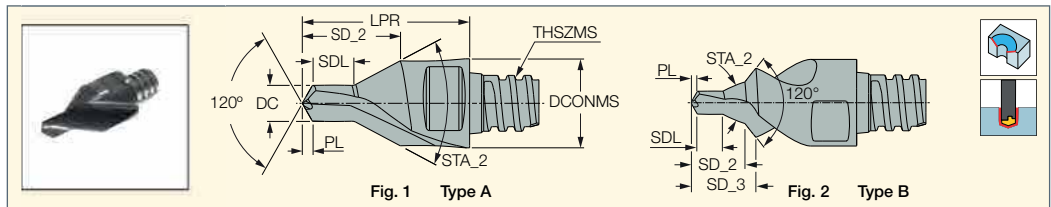

Designation	Dimensions										IC908
	DC	DCONMS	THSZMS	LPR	SDL	SD_2	SD_3	STA_2	PL	Fig.	
MM ECS-A1.00X06-2T04	1.07	6.00	T04	10.00	1.32	4.14	-	60.0	0.280	1	●
MM ECS-A1.60X06-2T04	1.65	6.00	T04	10.00	1.97	4.45	-	60.0	0.430	1	●
MM ECS-A2.00X06-2T04	2.07	6.00	T04	10.00	2.36	6.37	-	60.0	0.540	1	●
MM ECS-A3.15X08-2T05	3.28	8.00	T05	15.00	3.75	8.76	-	60.0	0.850	1	●
MM ECS-A4.00X10-2T06	4.12	10.00	T06	19.00	4.83	11.05	-	60.0	1.070	1	●
MM ECS-A5.00X12-2T08	5.13	12.00	T08	23.00	5.88	13.23	-	60.0	1.320	1	●
MM ECS-A6.30X16-2T10	6.46	16.00	T10	28.00	7.25	17.18	-	60.0	1.650	1	●
MM ECS-B3.15X12-2T08	3.24	12.00	T08	23.00	3.55	7.40	8.94	60.0	0.830	2	●
MM ECS-B4.00X127-2T08	4.09	12.70	T08	23.00	4.53	9.50	10.71	60.0	1.070	2	●
MM ECS-B5.00X19-2T12	5.09	18.45	T12	25.50	5.56	11.70	14.17	60.0	1.330	2	●
MM ECS-B6.30X20-2T12	6.41	18.45	T12	25.50	6.95	14.50	16.58	60.0	1.680	2	●

- For shanks, see pages 79-86 • For clamping keys (to be ordered separately), tightening torques and clamping instructions, see pages 10-11
- Do not apply lubricant to the threaded connection. • For user guide, see pages 9,12-13

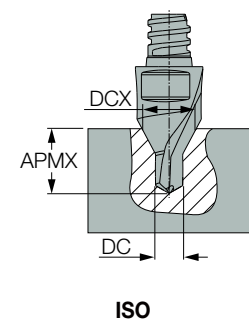

		IC908						
		*V _c x f _z [m/min x mm/tooth]						
		MM ECS-A1.00X06-2T04	MM ECS-A1.60X06-2T04	MM ECS-A2.00X06-2T04	MM ECS-A3.15X08-2T05	MM ECS-A4.00X10-2T06	MM ECS-A5.00X12-2T08	MM ECS-A6.30X16-2T10
ISO		DCX=2.12, APMX=2.5	DCX=3.35, APMX=3.9	DCX=4.25, APMX=4.8	DCX=6.70, APMX=7.60	DCX=8.50, APMX=9.80	DCX=10.60, APMX=12.00	DCX=13.20, APMX=14.80
P	4340 24-29HRC	80x0.020	80x0.025	80x0.025	80x0.030	80x0.040	80x0.050	80x0.060
	4340 38-42HRC	65x0.020	65x0.025	65x0.025	65x0.030	65x0.040	65x0.050	65x0.060
M	316L MAX-215 HB	50x0.015	50x0.020	50x0.020	50x0.025	50x0.030	50x0.040	50x0.040
S	Inconel 718	15x0.010	15x0.010	15x0.015	15x0.015	15x0.020	15x0.020	15x0.025

* V_c Calculated for ØDC

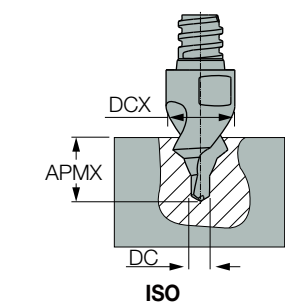

		IC908			
		*V _c x f _z [m/min x mm/tooth]			
		MM ECS-A3.15X12-2T08	MM ECS-A4.00X127-2T08	MM ECS-A5.00X19-2T12	MM ECS-A6.30X20-2T12
ISO		DCX=10.00, APMX=8.80	DCX=12.50, APMX=11.00	DCX=16.00, APMX=13.900	DCX=18.00, APMX=16.80
P	4340 24-29HRC	75x0.030	75x0.040	75x0.050	75x0.060
	4340 38-42HRC	60x0.030	60x0.040	60x0.050	60x0.060
M	316L MAX-215 HB	45x0.025	45x0.030	45x0.040	45x0.040
S	Inconel 718	12x0.015	12x0.020	12x0.020	12x0.025

* V_c Calculated for ØDC

SOLIDDRILL
MULTI-MASTER

MM ECD
NC Spot Drills for Accurate Hole Location without the need for a Bushing Guide.

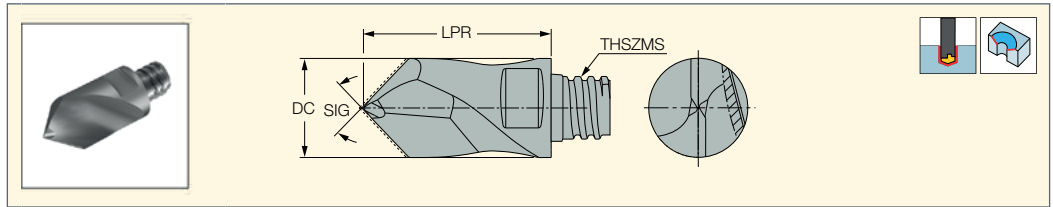

Designation	Dimensions				IC908
	DC	LPR	THSZMS	SIG	
MM ECD-06X145-2T04	6.00	8.50	T04	145	●
MM ECD-06X90-2T04	6.00	11.00	T04	90	●
MM ECD-08X145-2T05	8.00	10.00	T05	145	●
MM ECD-08X90-2T05	8.00	15.00	T05	90	●
MM ECD-10X145-2T06	10.00	13.00	T06	145	●
MM ECD-10X90-2T06	10.00	19.00	T06	90	●
MM ECD-12X145-2T08	12.00	16.50	T08	145	●
MM ECD-12X90-2T08	12.00	23.00	T08	90	●
MM ECD-16X145-2T10	16.00	20.50	T10	145	●
MM ECD-16X90-2T10	16.00	28.00	T10	90	●

- For shanks, see pages 79-86 • For clamping keys (to be ordered separately), tightening torques and clamping instructions, see pages 10-11
- Do not apply lubricant to the threaded connection

MULTI-MASTER
INDEXABLE SOLID CARBIDE LINE
MM EFCB
Interchangeable 4 Flute 30° Helix Solid Carbide Heads for Flat Counter Boring

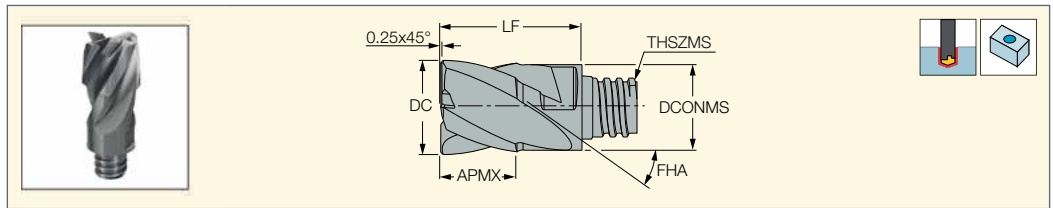

Designation	Dimensions									IC908	Recommended Machining Data
	DC ⁽¹⁾	APMX	LF	DCONMS	THSZMS	NOF ⁽²⁾	FHA	CHW	KCH		f _z (mm/t)
MM EFCB110A08-4T06	11.00	8.40	16.50	10.00	T06	4	30.0	45.0	0.25	●	0.03-0.04
MM EFCB140A11-4T08	14.00	11.50	28.00	12.00	T08	4	30.0	45.0	0.25	●	0.04-0.05

- 0.06 mm maximum concavity on the tool's bottom • For shanks, see pages 79-86
- For clamping keys (to be ordered separately), tightening torques and clamping instructions, see pages 10-11
- Do not apply lubricant to the threaded connection. • For user guide, see pages 9,12-13

⁽¹⁾ e8 tolerance

⁽²⁾ Number of flutes

SOLIDDRILL
MULTI-MASTER

MM ECDF
MULTI-MASTER
Exchangeable Solid Carbide
Flat Bottom Drill Heads

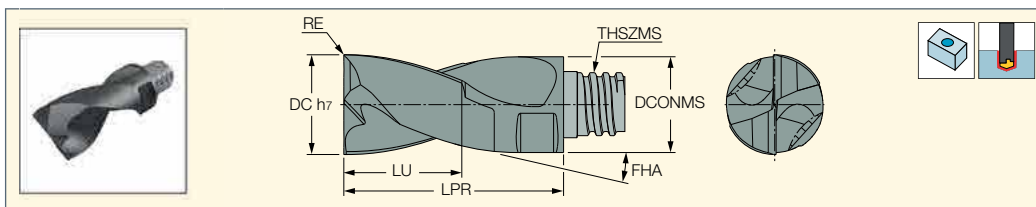

Designation	Dimensions								IC908
	DC	DCONMS	NOF ⁽¹⁾	LU	LPR	RE	FHA	THSZMS	
MM ECDF080A100-2T05	8.00	7.70	2	12.00	22.00	0.00	30.0	T05	●
MM ECDF085A120-2T05	8.50	7.70	2	12.00	22.00	0.00	30.0	T05	●
MM ECDF090A120-2T05	9.00	7.70	2	12.00	22.00	0.00	30.0	T05	●
MM ECDF095A120-2T06	9.50	9.20	2	12.00	22.00	0.00	30.0	T06	●
MM ECDF100A120-2T06	10.00	9.60	2	12.00	22.00	0.00	30.0	T06	●
MM ECDF105A120-2T06	10.50	9.60	2	12.00	23.00	0.00	30.0	T06	●
MM ECDF110A120-2T06	11.00	9.60	2	12.00	23.00	0.00	30.0	T06	●
MM ECDF115A120-2T06	11.50	9.60	2	12.00	23.00	0.00	30.0	T06	●
MM ECDF120A150-2T08	12.00	11.70	2	15.00	27.00	0.00	30.0	T08	●
MM ECDF125A150-2T08	12.50	12.10	2	15.00	27.00	0.00	30.0	T08	●
MM ECDF130A150-2T08	13.00	12.20	2	15.00	27.00	0.00	30.0	T08	●
MM ECDF135A150-2T08	13.50	12.20	2	15.00	27.00	0.00	30.0	T08	●
MM ECDF140A150-2T08	14.00	12.20	2	15.00	27.00	0.00	30.0	T08	●
MM ECDF145A150-2T08	14.50	12.20	2	15.00	27.00	0.00	30.0	T08	●
MM ECDF150A150-2T08	15.00	12.20	2	15.00	27.00	0.00	30.0	T08	●
MM ECDF155A150-2T08	15.50	12.20	2	15.00	27.00	0.00	30.0	T08	●
MM ECDF160A200-2T10	16.00	15.30	2	20.00	33.50	0.00	30.0	T10	●
MM ECDF165A200-2T10	16.50	15.30	2	20.00	33.50	0.00	30.0	T10	●
MM ECDF170A200-2T10	17.00	15.30	2	20.00	33.50	0.00	30.0	T10	●
MM ECDF175A200-2T10	17.50	15.30	2	20.00	33.50	0.00	30.0	T10	●
MM ECDF180A200-2T10	18.00	15.30	2	20.00	33.50	0.00	30.0	T10	●
MM ECDF185A200-2T12	18.50	18.20	2	25.00	41.00	0.00	30.0	T12	●
MM ECDF190A250-2T12	19.00	18.30	2	25.00	41.00	0.00	30.0	T12	●
MM ECDF195A250-2T12	19.50	18.30	2	25.00	41.00	0.00	30.0	T12	●
MM ECDF200A250-2T12	20.00	18.45	2	25.00	41.00	0.00	30.0	T12	●

- For shanks, see pages 79-86 • For clamping keys (to be ordered separately), tightening torques and clamping instructions, see pages 10-11
 - Do not apply lubricant to the threaded connection. • For user guide, see pages 9,12-13
- ⁽¹⁾ Number of flutes

Recommended Machining Conditions for MM ECDF Heads DC=8.0-25.4 mm

ISO	Material	Condition	Tensile Strength [N/mm ²]	Hardness HB	Material Group No.	V m/min	Feed vs. Flat-Drill Diameter					
							DC=8.0-9.9	DC=10.0-12.9	DC=13.0-15.9	DC=16.0-17.9	DC=18.0-25.4	
							frev mm/rev					
P	Non-alloy steel and cast steel, free cutting steel	< 0.25 %C	Annealed	420	125	1	80-110-140	0.08	0.10	0.12	0.14	0.18
		≥ 0.25 %C	Annealed	650	190	2						
		< 0.55 %C	Quenched and tempered	850	250	3						
		≥ 0.55 %C	Quenched and tempered	1000	300	5						
	Low alloy and cast steel (less than 5% of alloying elements)	Annealed	750	220	4	80-105-130	0.12	0.14	0.18	0.20	0.24	
		Quenched and tempered	1000	300	5							
		Annealed	600	200	6	60-80-100	0.06	0.06	0.08	0.10	0.12	
		Quenched and tempered	930	275	7							
		Quenched and tempered	1000	300	8							
		Quenched and tempered	1200	350	9							
High alloyed steel, cast steel and tool steel	Annealed	680	200	10	60-80-100	0.10	0.10	0.12	0.14	0.16		
	Quenched and tempered	1100	325	11								
Stainless steel and cast steel	Ferritic/martensitic	680	200	12	60-80-100	0.01	0.02	0.03	0.04	0.06		
	Martensitic	820	240	13								
M	Stainless steel and cast steel	Austenitic, duplex	600	180	14	60-80-100	0.01	0.02	0.03	0.04	0.06	
K	Gray cast iron (GG)	Ferritic / pearlitic		180	17	80-120-160	0.08	0.10	0.14	0.16	0.18	
		Pearlitic / martensitic		260	18							
	Nodular cast iron (GGG)	Ferritic		160	15							
		Pearlitic		250	16							
		Ferritic		130	19							
Malleable cast iron	Pearlitic		230	20								

■ recommended cutting data

Exchangeable Heads with Indexable Inserts

DCN-MM

Modular SUMOCHAM Drills are Dedicated for Multi-Spindle and Swiss-Type Machines with a MULTI-MASTER Connection

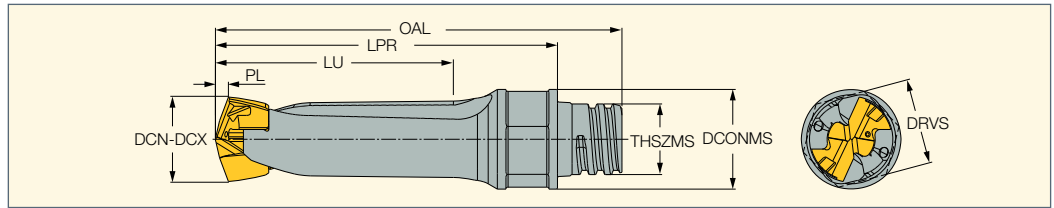

Designation	DCN ⁽¹⁾	DCX ⁽²⁾	DCONMS	LU	LPR	PL	OAL	THSZMS	SSC ⁽³⁾	MIID ⁽⁴⁾	DRVS ⁽⁵⁾
DCN 040-008-MMT05-2D	4.00	4.40	7.60	8.62	22.00	0.620	28.75	T05	4	ICP 040	5.5
DCN 045-009-MMT05-2D	4.50	4.90	7.60	9.66	23.30	0.660	30.05	T05	4.5	ICP 045	5.5
DCN 050-010-MMT06-2D	5.00	5.40	9.60	10.73	27.30	0.730	33.55	T06	5	ICP 050	8.0
DCN 055-011-MMT06-2D	5.50	5.90	9.60	11.81	27.50	0.810	33.80	T06	5.5	ICP 055	8.0

⁽¹⁾ Cutting diameter minimum

⁽²⁾ Cutting diameter maximum

⁽³⁾ Seat size code

⁽⁴⁾ Master insert identification

⁽⁵⁾ Torque key size

Spare Parts

Designation	
DCN-MM	 MM KEY 6X4



GROOVING

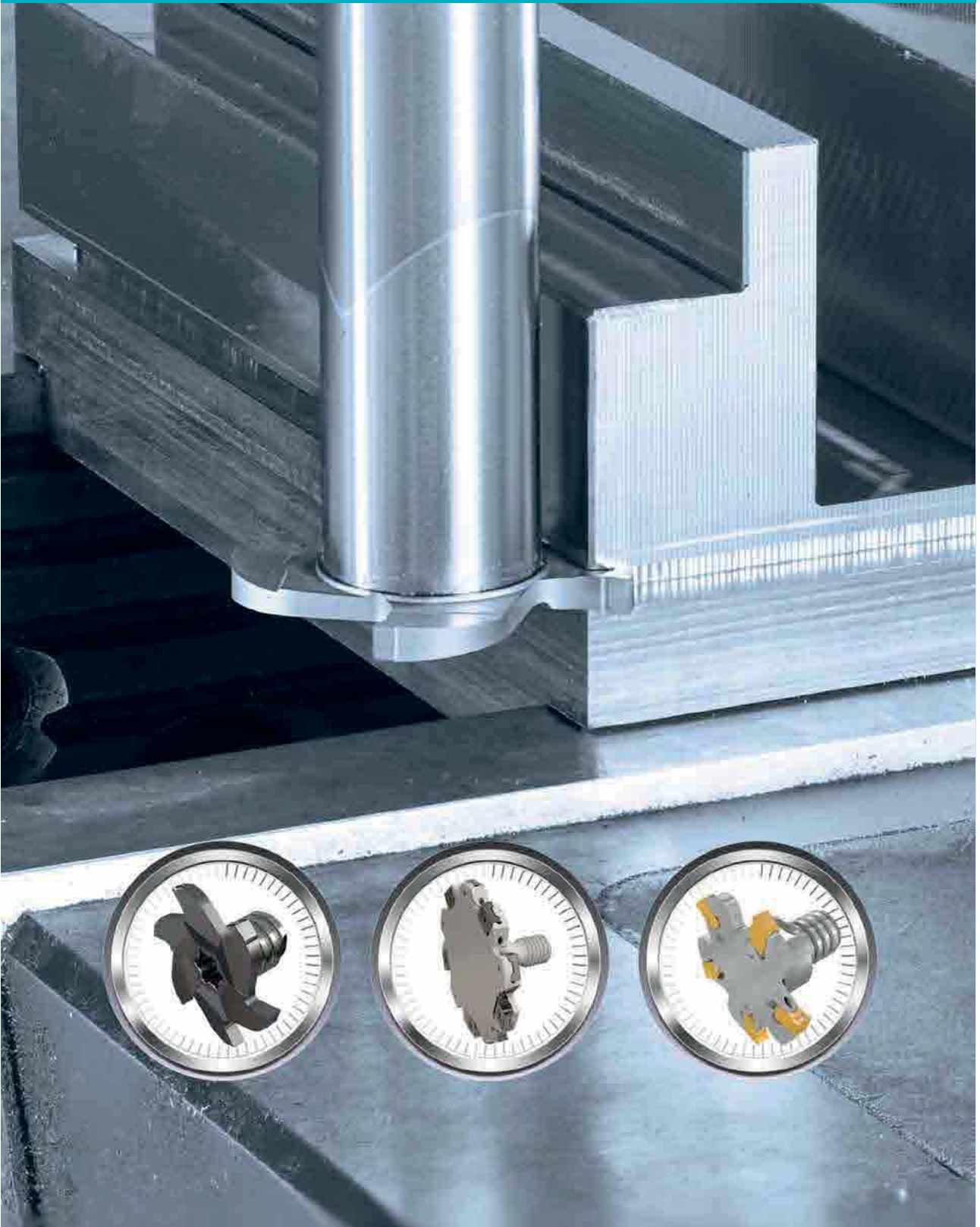

Exchangeable Solid Carbide Head

MULTI-MASTER
INDEXABLE SOLID CARBIDE LINE

MM GRIT-16K/P,18K/P 3T6
Interchangeable Solid Carbide Small Diameter Groove Milling Heads

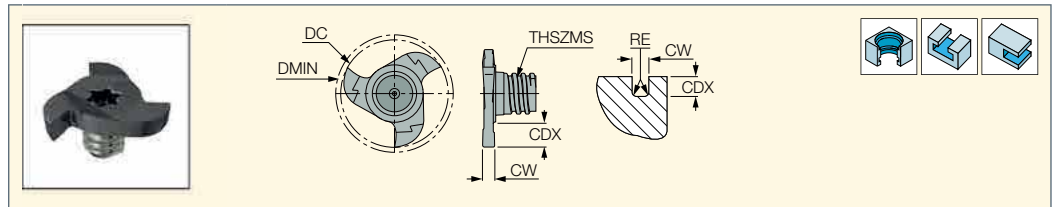

Designation	Dimensions								IC908
	DC	CW	CDX ⁽¹⁾	NOF ⁽²⁾	RE	DMIN ⁽³⁾	THSZMS	∠	
MM GRIT16K150-010-3T6	15.70	1.50	2.80	3	0.10	16.00	T06	T-20/3*	●
MM GRIT16P150-010-3T6	15.70	1.50	2.80	3	0.10	16.00	T06	T-20/3*	●
MM GRIT16K157-020-3T6	15.70	1.57	2.80	3	0.20	16.00	T06	T-25/3*	●
MM GRIT16K200-020-3T6	15.70	2.00	2.80	3	0.20	16.00	T06	T-20/3*	●
MM GRIT16P220-110-3T6	15.70	2.20	2.80	3	1.10	16.00	T06	T-20/3*	●
MM GRIT16K239-020-3T6	15.70	2.39	2.80	3	0.20	16.00	T06	T-25/3*	●
MM GRIT16K250-020-3T6	15.70	2.50	2.80	3	0.20	16.00	T06	T-25/3*	●
MM GRIT16K300-020-3T6	15.70	3.00	2.80	3	0.20	16.00	T06	T-25/3*	●
MM GRIT16P300-020-3T6	15.70	3.00	2.80	3	0.20	16.00	T06	T-25/3*	●
MM GRIT16K317-020-3T6	15.70	3.17	2.80	3	0.20	16.00	T06	T-25/3*	●
MM GRIT18K120-005-3T6	17.70	1.20	3.80	3	0.05	18.00	T06	T-20/3*	●
MM GRIT18P120-060-3T6	17.70	1.20	3.80	3	0.60	18.00	T06	T-20/3*	●
MM GRIT18K140-005-3T6	17.70	1.40	3.80	3	0.05	18.00	T06	T-20/3*	●
MM GRIT18K150-010-3T6	17.70	1.50	3.80	3	0.10	18.00	T06	T-20/3*	●
MM GRIT18K157-020-3T6	17.70	1.57	3.80	3	0.20	18.00	T06	T-20/3*	●
MM GRIT18K170-005-3T6	17.70	1.70	3.80	3	0.05	18.00	T06	T-20/3*	●
MM GRIT18K200-020-3T6	17.70	2.00	3.80	3	0.20	18.00	T06	T-20/3*	●
MM GRIT18P200-100-3T6	17.70	2.00	3.80	3	1.00	18.00	T06	T-20/3*	●
MM GRIT18P220-110-3T6	17.70	2.20	3.80	3	1.10	18.00	T06	T-20/3*	●
MM GRIT18K239-020-3T6	17.70	2.39	3.80	3	0.20	18.00	T06	T-20/3*	●
MM GRIT18K250-020-3T6	17.70	2.50	3.80	3	0.20	18.00	T06	T-20/3*	●
MM GRIT18K300-020-3T6	17.70	3.00	3.80	3	0.20	18.00	T06	T-25/3*	●
MM GRIT18P300-150-3T6	17.70	3.00	3.80	3	1.50	18.00	T06	T-25/3*	●
MM GRIT18K317-020-3T6	17.70	3.17	3.80	3	0.20	18.00	T06	T-25/3*	●

- Recommended for O-rings and retaining rings
- Modification options on request
- Do not apply lubricant to the threaded connection
- For clamping instructions, see pages 10-11
- For user guide, see pages 9,12-13
- For shanks, see pages 79-86
- K-Type - For general steel machining
- P-Type - Positive geometry for soft and gummy materials

⁽¹⁾ Cutting depth maximum

⁽²⁾ Number of flutes

⁽³⁾ Minimum bore diameter

* Optional, to be ordered separately

MM GRIT-4T8
Interchangeable Solid Carbide Small Diameter Groove Milling Heads

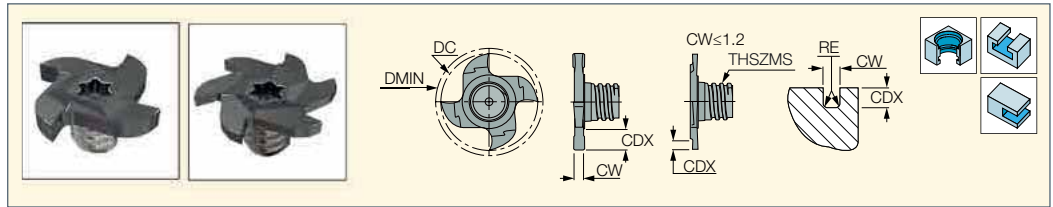

Designation	Dimensions								IC908
	DC	CW	CDX ⁽¹⁾	NOF ⁽²⁾	RE	DMIN ⁽³⁾	THSZMS	∠	
MM GRIT22K076-000-4T8	21.70	0.76	1.50	4	0.00	22.00	T08	T-25/3*	●
MM GRIT22K086-000-4T8	21.70	0.86	1.70	4	0.00	22.00	T08	T-25/3*	●
MM GRIT22K096-000-4T8	21.70	0.96	1.90	4	0.00	22.00	T08	T-25/3*	●
MM GRIT22K100-005-4T8	21.70	1.00	2.00	4	0.05	22.00	T08	T-25/3*	●
MM GRIT22P100-005-4T8	21.70	1.00	2.00	4	0.05	22.00	T08	T-25/3*	●
MM GRIT22K120-005-4T8	21.70	1.20	4.50	4	0.05	22.00	T08	T-25/3*	●
MM GRIT22K140-005-4T8	21.70	1.40	4.50	4	0.05	22.00	T08	T-25/3*	●
MM GRIT22K157-000-4T8	21.70	1.57	4.50	4	0.00	22.00	T08	T-25/3*	●
MM GRIT22K170-010-4T8	21.70	1.70	4.50	4	0.10	22.00	T08	T-25/3*	●
MM GRIT22P170-010-4T8	21.70	1.70	4.50	4	0.10	22.00	T08	T-25/3*	●
MM GRIT22K195-020-4T8	21.70	1.95	4.50	4	0.20	22.00	T08	T-25/3*	●
MM GRIT22K200-020-4T8	21.70	2.00	4.50	4	0.20	22.00	T08	T-25/3*	●
MM GRIT22P200-020-4T8	21.70	2.00	4.50	4	0.20	22.00	T08	T-25/3*	●
MM GRIT22K225-020-4T8	21.70	2.25	4.50	4	0.20	22.00	T08	T-25/3*	●
MM GRIT22K239-020-4T8	21.70	2.39	4.50	4	0.20	22.00	T08	T-25/3*	●
MM GRIT22K250-020-4T8	21.70	2.50	4.50	4	0.20	22.00	T08	T-25/3*	●
MM GRIT22P250-020-4T8	21.70	2.50	4.50	4	0.20	22.00	T08	T-25/3*	●
MM GRIT22K275-020-4T8	21.70	2.75	4.50	4	0.20	22.00	T08	T-25/3*	●
MM GRIT22K300-020-4T8	21.70	3.00	4.50	4	0.20	22.00	T08	T-30/3 L*	●
MM GRIT22P300-020-4T8	21.70	3.00	4.50	4	0.20	22.00	T08	T-30/3 L*	●
MM GRIT22K317-020-4T8	21.70	3.17	4.50	4	0.20	22.00	T08	T-30/3 L*	●
MM GRIT22K325-020-4T8	21.70	3.25	4.50	4	0.20	22.00	T08	T-30/3 L*	●
MM GRIT22P381-020-4T8	21.70	3.81	4.50	4	0.20	22.00	T08	T-30/3 L*	●
MM GRIT22K400-020-4T8	21.70	4.00	4.50	4	0.20	22.00	T08	T-30/3 L*	●
MM GRIT22P400-020-4T8	21.70	4.00	4.50	4	0.20	22.00	T08	T-30/3 L*	●
MM GRIT22P400-200-4T8	21.70	4.00	4.50	4	2.00	22.00	T08	T-30/3 L*	●
MM GRIT22K425-020-4T8	21.70	4.25	4.50	4	0.20	22.00	T08	T-30/3 L*	●
MM GRIT22K425-120-4T8	21.70	4.25	4.50	4	1.20	22.00	T08	T-30/3 L*	●
MM GRIT22K475-020-4T8	21.70	4.75	4.50	4	0.20	22.00	T08	T-30/3 L*	●
MM GRIT22K525-020-4T8	21.70	5.25	4.50	4	0.20	22.00	T08	T-30/3 L*	●
MM GRIT22K600-300-4T8	21.70	6.00	4.50	4	3.00	22.00	T08	T-30/3 L*	●
MM GRIT28K250-020-6T10	27.70	2.50	6.00	6	0.20	28.00	T10	T-40/3 L*	●
MM GRIT28K525-020-6T10	27.70	5.25	6.00	6	0.20	28.00	T10	T-40/3 L*	●
MM GRIT28P700-350-6T10	27.70	7.00	6.00	6	3.50	28.00	T10	T-40/3 L*	●
MM GRIT28K1000-020-6T10	27.70	10.00	6.00	6	0.20	28.00	T10	T-40/3 L*	●
MM GRIT28K1100-020-6T10	27.70	11.00	6.00	6	0.20	28.00	T10	T-40/3 L*	●
MM GRIT28K1200-020-6T10	27.70	12.00	6.00	6	0.20	28.00	T10	T-40/3 L*	●
MM GRIT28K1300-020-6T10	27.70	13.00	6.00	6	0.20	28.00	T10	T-40/3 L*	●

- Recommended for Orings and retaining rings
- K - for general steel & cast iron machining
- P - for soft and gummy materials
- Modification options on request
- Do not apply lubricant to the threaded connection
- For clamping instructions, see pages 10-11
- For user guide, see pages 9,12-13
- For shanks, see pages 79-86

⁽¹⁾ Cutting depth maximum



⁽²⁾ Number of flutes

⁽³⁾ Minimum bore diameter

* Optional, to be ordered separately

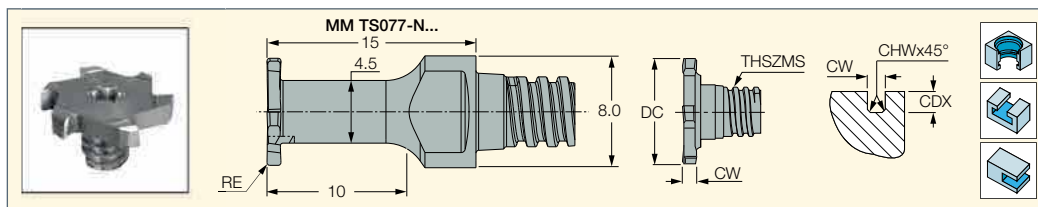
MM TS-N
Interchangeable Solid Carbide
T-Slot Milling Heads



Designation	Dimensions										Tough ↔ Hard	
	DC	DCTOLL	CW	NOF ⁽¹⁾	THSZMS	CDX ⁽²⁾	RE	CHW			IC928	IC908
MM TS077-N07A-4T05	7.70	-0.0500	0.70	4	T05	1.20	0.20	-	MM KEY 6X4*			●
MM TS077-N08A-4T05	7.70	-0.0500	0.80	4	T05	1.20	0.20	-	MM KEY 6X4*			●
MM TS077-N09A-4T05	7.70	-0.0500	0.90	4	T05	1.20	0.20	-	MM KEY 6X4*			●
MM TS077-N10A-4T05	7.70	-0.0500	1.00	4	T05	1.20	0.20	-	MM KEY 6X4*			●
MM TS077-N15A-4T05	7.70	-0.0500	1.50	4	T05	1.20	0.20	-	MM KEY 6X4*			●
MM TS077-N20A-4T05	7.70	-0.0500	2.00	4	T05	1.20	0.20	-	MM KEY 6X4*			●
MM TS105-N20D-06T04	10.50	-0.0500	2.00	6	T04	2.00	0.40	-		T-15/3*	●	
MM TS.500-N062P-06T05	12.70	-0.0500	1.58	6	T05	2.25	-	0.15				●
MM TS.500-N078P-06T05	12.70	-0.0500	1.98	6	T05	2.25	-	0.15				●
MM TS135-N20P-06T05	13.50	-0.0500	2.00	6	T05	2.65	-	0.20		T-20/3*		●
MM TS135-N25P-06T05	13.50	-0.0500	2.50	6	T05	2.65	-	0.20		T-20/3*		●

• For shanks, see pages 79-86 • For tightening torques and clamping instructions, see pages 10-11 • Do not apply lubricant to the threaded connection

• For user guide, see pages 9,12-13

⁽¹⁾ Number of flutes

⁽²⁾ Cutting depth maximum

* Optional, to be ordered separately

MM TS-H
Interchangeable Solid Carbide
T-Slot Milling Heads with
Diverse Corner Radii

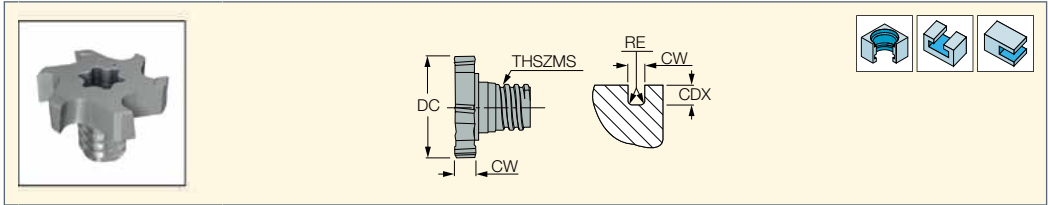

Designation	Dimensions								IC908
	DC	DCTOLL	CW	CDX ⁽¹⁾	NOF ⁽²⁾	RE	THSZMS	∠	
MM TS135-H30D-06T05	13.50	-0.0500	3.00	2.65	6	0.40	T05	T-20/3*	●
MM TS135-H40D-06T05	13.50	-0.0500	4.00	2.65	6	0.40	T05	T-20/3*	●
MM TS165-H40A-06T05	16.50	-0.0500	4.00	4.25	6	0.20	T05	T-20/3*	●
MM TS160-H20D-06T06	16.00	-0.0500	2.00	3.00	6	0.40	T06	T-20/3*	●
MM TS160-H30D-06T06	16.00	-0.0500	3.00	3.00	6	0.40	T06	T-25/3*	●
MM TS160-H40D-06T06	16.00	-0.0500	4.00	3.00	6	0.40	T06	T-25/3*	●
MM TS165-H20D-06T06	16.50	-0.0500	2.00	3.25	6	0.40	T06	T-20/3*	●
MM TS165-H30D-06T06	16.50	-0.0500	3.00	3.25	6	0.40	T06	T-25/3*	●
MM TS165-H40D-06T06	16.50	-0.0500	4.00	3.25	6	0.40	T06	T-25/3*	●
MM TS195-H60A-06T06	19.50	-0.0500	6.00	4.45	6	0.20	T06	T-25/3*	●
MM TS225-H60A-06T06	22.50	-0.0500	6.00	5.95	6	0.20	T06	T-25/3*	●
MM TS195-H40D-06T08	19.50	-0.0500	4.00	3.45	6	0.40	T08	T-30/3 L*	●
MM TS195-H50D-06T08	19.50	-0.0500	5.00	3.45	6	0.40	T08	T-30/3 L*	●
MM TS195-H60D-06T08	19.50	-0.0500	6.00	3.45	6	0.40	T08	T-30/3 L*	●
MM TS225-H40D-06T08	22.50	-0.0500	4.00	4.90	6	0.40	T08	T-40/3 L*	●
MM TS225-H50D-06T08	22.50	-0.0500	5.00	4.95	6	0.40	T08	T-40/3 L*	●
MM TS225-H60D-06T08	22.50	-0.0500	6.00	4.95	6	0.40	T08	T-40/3 L*	●
MM TS225-H80D-06T08	22.50	-0.0500	8.00	4.95	6	0.40	T08	T-40/3 L*	●
MM TS250-H50D-06T08	25.00	-0.0500	5.00	5.90	6	0.40	T08	T-50/3 L*	●
MM TS250-H60D-06T08	25.00	-0.0500	6.00	5.90	6	0.40	T08	T-50/3 L*	●
MM TS250-H80D-06T08	25.00	-0.0500	8.00	5.90	6	0.40	T08	T-50/3 L*	●
MM TS250-H50D-06T10	25.00	-0.0500	5.00	4.30	6	0.40	T10	T-50/3 L*	●
MM TS250-H60D-06T10	25.00	-0.0500	6.00	4.30	6	0.40	T10	T-50/3 L*	●
MM TS250-H80D-06T10	25.00	-0.0500	8.00	4.30	6	0.40	T10	T-50/3 L*	●

- Inserts in 5 mm and wider feature chip splitting edges
- For tightening torques and clamping instructions, see pages 10-11
- Do not apply lubricant to the threaded connection
- For shanks, see pages 79-86
- For user guide, see pages 9,12-13

⁽¹⁾ Cutting depth maximum

⁽²⁾ Number of flutes

* Optional, to be ordered separately

MM TS-C
Interchangeable Solid Carbide
Circlip Groove Milling Heads
Conform to DIN 471/472

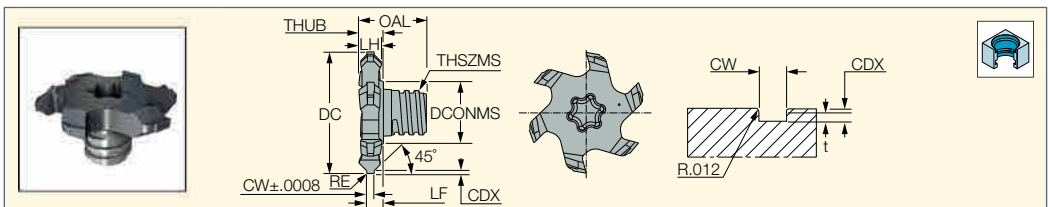

Designation	Dimensions												IC928	
	DC	CW	CDX	LF	t	RE	THUB	LH	OAL	DCONMS	NOF ⁽¹⁾	THSZMS		
MM TS127C118T035-6T05	12.70	1.18	0.35	2.23	0.27	0.05	3.00	2.7	8.43	7.70	6	T05	T-20/3*	●
MM TS127C118T040-6T05	12.70	1.18	0.40	2.23	0.32	0.05	3.00	2.7	8.43	7.70	6	T05	T-20/3*	●
MM TS127C118T050-6T05	12.70	1.18	0.50	2.23	0.42	0.05	3.00	2.7	8.43	7.70	6	T05	T-20/3*	●
MM TS127C138T050-6T05	12.70	1.38	0.50	2.23	0.42	0.05	3.00	2.7	8.63	7.70	6	T05	T-20/3*	●
MM TS225C138T060-6T08	22.50	1.38	0.60	3.08	0.50	0.05	4.50	4.2	9.48	11.70	6	T08	T-40/3 L*	●
MM TS225C138T070-6T08	22.50	1.38	0.70	3.08	0.60	0.05	4.50	4.2	9.48	11.70	6	T08	T-40/3 L*	●
MM TS225C138T085-6T08	22.50	1.38	0.85	3.08	0.74	0.05	4.50	4.2	9.48	11.70	6	T08	T-40/3 L*	●
MM TS225C168T070-6T08	22.50	1.68	0.70	3.23	0.60	0.10	4.50	4.2	9.78	11.70	6	T08	T-40/3 L*	●
MM TS225C168T085-6T08	22.50	1.68	0.85	3.23	0.74	0.10	4.50	4.2	9.78	11.70	6	T08	T-40/3 L*	●
MM TS225C168T100-6T08	22.50	1.68	1.00	3.23	0.89	0.10	4.50	4.2	9.78	11.70	6	T08	T-40/3 L*	●
MM TS225C193T100-6T08	22.50	1.93	1.00	3.35	0.89	0.10	4.50	4.2	10.03	11.70	6	T08	T-40/3 L*	●
MM TS225C193T125-6T08	22.50	1.93	1.25	3.35	1.13	0.10	4.50	4.2	10.03	11.70	6	T08	T-40/3 L*	●
MM TS225C223T150-6T08	22.50	2.23	1.50	3.50	1.38	0.10	4.50	4.2	10.33	11.70	6	T08	T-40/3 L*	●
MM TS225C273T150-6T08	22.50	2.73	1.50	3.77	1.39	0.20	4.50	4.1	10.83	11.70	6	T08	T-40/3 L*	●
MM TS225C273T175-6T08	22.50	2.73	1.75	3.77	1.64	0.20	4.40	3.9	10.83	11.70	6	T08	T-40/3 L*	●
MM TS225C325T175-6T08	22.50	3.25	1.75	4.40	1.64	0.20	5.10	4.6	11.35	11.70	6	T08	T-40/3 L*	●

- For shanks, see pages 79-86
- For tightening torques and clamping instructions, see pages 10-11
- Do not apply lubricant to the threaded connection

- For user guide, see pages 9,12-13

⁽¹⁾ Number of flutes

* Optional, to be ordered separately

MM TS-DG

Double Groove Internal Grooving Heads with a Threaded Connection for Heat Exchanger Tube Sheets

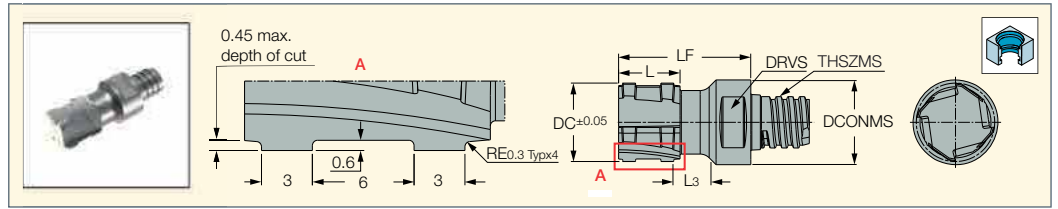

Designation	Dimensions										IC908
	DC	DCONMS	PHD ⁽¹⁾	THSZMS	NOF ⁽²⁾	LF	L3	L	DRVS ⁽³⁾		
MM TS155-04T10-8238	15.50	16.00	15.88	T10	4	33.70	17.80	14.20	10.0	MM KEY 10X7*	●
MM TS185-04T12-8239	18.50	18.45	19.05	T12	4	34.50	18.30	14.50	13.0	MM KEY 13X8*	●
MM TS245-04T15-8240	24.50	23.80	25.40	T15	4	37.20	11.00	14.40	20.0	MM KEY 20*	●

- For shanks, see pages 79-86
- For clamping keys (to be ordered separately), tightening torques and clamping instructions, see pages 10-11
- Do not apply lubricant to the threaded connection
- For user guide, see pages 9,12-13

⁽¹⁾ For minimum tube outer diameter

⁽²⁾ Number of flutes

⁽³⁾ Clamping wrench size

* Optional, to be ordered separately

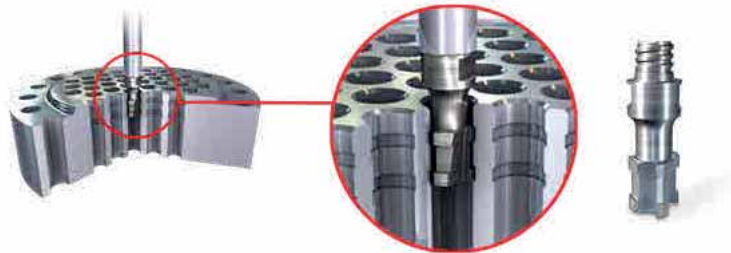

MM SS

Interchangeable Solid Carbide Heads for Milling Involute Spline Shafts According to DIN 5480

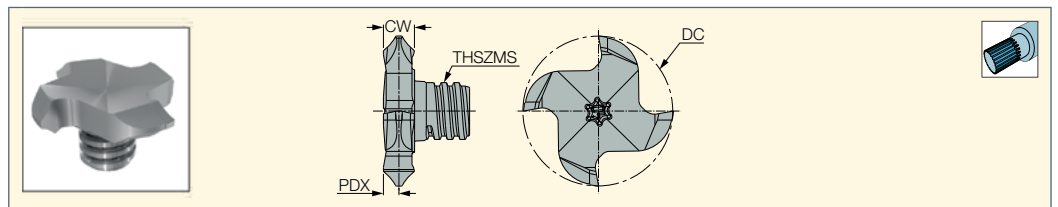

Designation	Dimensions								IC908
	Module	T range ⁽¹⁾	DC	PDX	CW	NOF ⁽²⁾	THSZMS		
MM SS22M100Z1720-4T08	1.00	17-20	21.70	2.8	5.50	4	T08	T-30/3 L	●
MM SS22M100Z2125-4T08	1.00	21-25	21.70	2.3	4.50	4	T08	T-30/3 L	●
MM SS22M150Z1720-4T08	1.50	17-20	21.70	2.7	5.40	4	T08	T-30/3 L	●

- Tightening torque 1500 NxcM
- Do not apply lubricant to the threaded connection.
- For clamping instructions, see pages 10-11
- For user guide, see pages 9,12-13
- For shanks, see pages 79-86

⁽¹⁾ Teeth range

⁽²⁾ Number of flutes

* Optional, to be ordered separately

T-SLOT

SD-SP
Interchangeable Solid Carbide
T-Slot Milling Heads

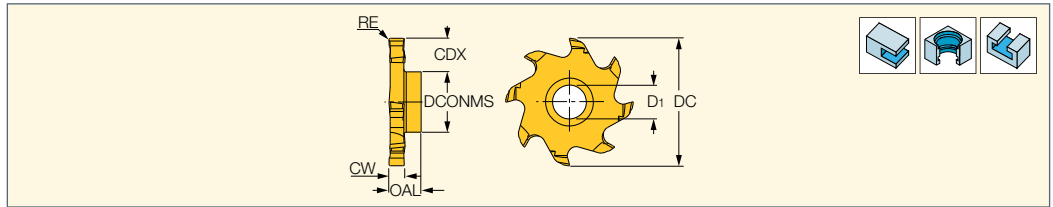

Designation	Dimensions								IC908
	DC	CW	CDX ⁽²⁾	NOF ⁽³⁾	RE	D1	DCONMS	OAL	
SD D32-1.0-R0.2-SP15	31.70	1.00	8.00	8	0.20	8.40	15.00	8.00	●
SD D32-1.5-R0.2-SP15	31.70	1.50	8.00	8	0.20	8.40	15.00	8.00	●
SD D32-2.0-R0.2-SP11	31.70	2.00	10.00	8	0.20	7.20	11.00	6.75	●
SD D32-2.0-R0.2-SP15	31.70	2.00	8.00	8	0.20	8.40	15.00	8.00	●
SD D32-2.5-R0.4-SP15	31.70	2.50	8.00	8	0.40	8.40	15.00	8.00	●
SD D32-3.0-R0.4-SP11	31.70	3.00	10.00	8	0.40	7.20	11.00	6.75	●
SD D32-3.0-R0.4-SP15	31.70	3.00	8.00	8	0.40	8.40	15.00	8.00	●
SD D32-3.5-R0.4-SP15	31.70	3.50	8.00	8	0.40	8.40	15.00	8.00	●
SD D32-4.0-R0.4-SP15	31.70	4.00	8.00	8	0.40	8.40	15.00	8.00	●
SD D32-4.0-R1.6-SP15	31.70	4.00	8.00	8	1.60	8.40	15.00	8.00	●
SD D32-4.5-R0.4-SP15	31.70	4.50	8.00	8	0.40	8.40	15.00	8.00	●
SD D32-5.0-R0.4-SP15	31.70	5.00	8.00	8	0.40	8.40	15.00	8.00	●
SD D32-5.0-R1.6-SP15	31.70	5.00	8.00	8	1.60	8.40	15.00	8.00	●
SD D32-5.5-R0.4-SP15	31.70	5.50	8.00	8	0.40	8.40	15.00	8.00	●
SD D32-6.0-R0.4-SP15	31.70	6.00	8.00	8	0.40	8.40	15.00	8.00	●
SD D32-6.0-R1.6-SP15	31.70	6.00	8.00	8	1.60	8.40	15.00	8.00	●
SD D32-6.5-R0.4-SP15	31.70	6.50	8.00	8	0.40	8.40	15.00	8.00	●
SD D32-7.0-R0.4-SP15	31.25	7.00	7.75	8	0.40	8.40	15.00	8.00	●
SD D32-7.0-R1.6-SP15	31.70	7.00	7.75	8	1.60	8.40	15.00	8.00	●
SD D32-7.5-R0.4-SP15	31.25	7.50	7.75	8	0.40	8.40	15.00	8.00	●
SD D32-8.0-R0.4-SP15	31.25	8.00	7.75	8	0.40	8.40	15.00	8.00	●
SD D32-8.0-R1.6-SP15	31.70	8.00	7.75	8	1.60	8.40	15.00	8.00	●
SD D32-8.5-R0.4-SP15	31.25	8.50	7.75	8	0.40	8.40	15.00	8.00	●
SD D40-1.0-R0.2SP13	39.70	1.00	13.00	10	0.20	7.50	13.00	7.30	●
SD D40-1.5-R0.2SP13	39.70	1.50	13.00	10	0.20	7.50	13.00	7.30	●
SD D40-2.0-R0.2SP13	39.70	2.00	13.00	10	0.20	7.50	13.00	7.30	●
SD D40-2.5-R0.4SP13	39.70	2.50	13.00	10	0.40	7.50	13.00	7.30	●
SD D40-3.0-R0.4SP13	39.70	3.00	13.00	10	0.40	7.50	13.00	7.30	●
SD D40-3.5-R0.4SP13	39.70	3.50	13.00	10	0.40	7.50	13.00	7.30	●
SD D40-4.0-R0.4SP13 ⁽¹⁾	39.70	4.00	13.00	10	0.40	7.50	13.00	7.30	●
SD D40-4.0-R0.4SP17	39.70	4.00	11.00	10	0.40	7.50	17.00	10.00	●
SD D40-5.0-R0.4SP17	39.70	5.00	11.00	10	0.40	9.80	17.00	10.00	●
SD D40-6.0-R0.4SP17	39.70	6.00	11.00	10	0.40	9.80	17.00	10.00	●
SD D40-7.0-R0.4SP17	39.70	7.00	11.00	10	0.40	9.80	17.00	10.00	●
SD D40-8.0-R0.4SP17	39.70	8.00	11.00	10	0.40	9.80	17.00	10.00	●
SD D40-9.0-R0.4SP17	39.70	9.00	11.00	10	0.40	9.80	17.00	10.00	●
SD D40-10-R0.4SP17	39.70	10.00	11.00	10	0.40	9.80	17.00	10.00	●
SD D50-4.0-R0.4-SP19	49.70	4.00	15.00	12	0.40	9.80	19.00	14.00	●
SD D50-5.0-R0.4-SP19	49.70	5.00	15.00	12	0.40	9.80	19.00	14.00	●
SD D50-6.0-R0.4-SP19	49.70	6.00	15.00	12	0.40	9.80	19.00	14.00	●
SD D50-7.0-R0.4-SP19	49.70	7.00	15.00	12	0.40	9.80	19.00	14.00	●
SD D50-8.0-R0.4-SP19	49.70	8.00	15.00	12	0.40	9.80	19.00	14.00	●
SD D50-9.0-R0.4-SP19	49.70	9.00	15.00	12	0.40	9.80	19.00	14.00	●
SD D50-10-R0.4-SP19	49.70	10.00	15.00	12	0.40	9.80	19.00	14.00	●
SD D50-12-R0.4-SP19	49.70	12.00	15.00	12	0.40	9.80	19.00	14.00	●

• For shanks, see pages 79-87 • For user guide, see pages 9,12-13

⁽¹⁾ Maximum feed: 0.1 mm/tooth

⁽²⁾ Cutting depth maximum

⁽³⁾ Number of flutes

Cutting Data for SD-SP Milling Heads

ISO class DIN/ ISO 513	Description	ISCAR mat. group*	Workpiece Material			Cutting Speed V _c m/min	Feed for SP11	Feed for SP13	Feed for SP15	Feed for SP17	Feed for SP19
			Typical Representative		Hardness HB		f _z	f _z	f _z	f _z	f _z
			AISI/SAE/ ASTM	DIN W.-Nr.			mm/tooth	mm/tooth	mm/tooth	mm/tooth	mm/tooth
P	Non-alloy steel	1	1020	1.0402	130-180	130-200	0.06-0.12	0.06-0.12	0.07-0.15	0.07-0.15	0.07-0.15
	Low alloy steel	8	4340	1.6511	260-300	120-170	0.06-0.12	0.06-0.12	0.07-0.15	0.07-0.15	0.07-0.15
	Low alloy steel	9	3135	1.5710	HRC 35-40*	80-120	0.02-0.06	0.02-0.06	0.03-0.12	0.04-0.12	0.04-0.13
	High alloy steel	10	H13	1.2344	200-220	100-140	0.04-0.07	0.04-0.07	0.04-0.12	0.04-0.12	0.05-0.13
	Martensitic s.s.	12	420	1.4021	200	100-140	0.03-0.06	0.03-0.06	0.04-0.12	0.04-0.12	0.04-0.13
M	Austenitic s.s.	14	304L	1.4306	200	80-120	0.02-0.06	0.02-0.06	0.03-0.10	0.03-0.12	0.03-0.12
K	Grey cast iron	16	Class 40	0.6025 (GG25)	250	160-200	0.05-0.12	0.05-0.12	0.05-0.20	0.06-0.20	0.06-0.20
	Nodular cast iron	17	Class 65-45-12	0.7050 (GGG50)	200	140-180	0.05-0.11	0.05-0.11	0.05-0.18	0.06-0.18	0.06-0.20
S	High temperature alloys	34	Inconel 718	2.4668	HRC 36-40	20-30	0.02-0.12	0.02-0.12	0.02-0.12	0.02-0.12	0.02-0.13
		37	AMS R56400	3.7165 (Ti6Al4V)	HRC 40-45	35-45	0.02-0.06	0.02-0.06	0.02-0.12	0.02-0.12	0.02-0.13

* ISCAR material group in accordance with VDI 3323 standard
 ** Quenched and tempered
 When machining in unstable conditions, the table values should be reduced by 20-30%.



SD-M-N-SP
 Interchangeable Solid Carbide Heads for Involute Gear Profile Milling According to DIN 3972 Basic Profile II

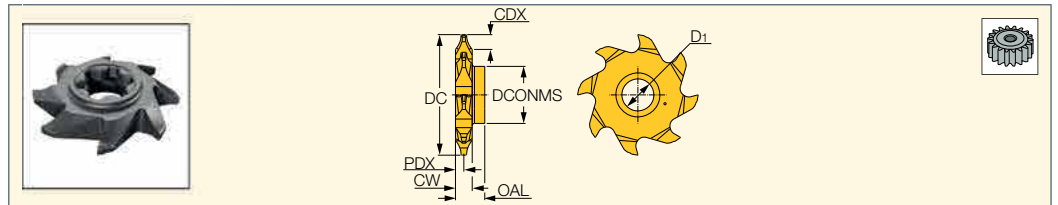

Designation	Dimensions										IC908
	Module	T range ⁽¹⁾	DC	PDX	CW	CDX	CEDC ⁽²⁾	DCONMS	D1	OAL	
SD D32-M1.00-N01-SP15	1.00	12-13	32.00	2.20	4.40	2.50	8	15.00	8.40	7.70	●
SD D32-M1.00-N02-SP15	1.00	14-16	32.00	2.20	4.40	2.50	8	15.00	8.40	7.70	●
SD D32-M1.25-N03-SP15	1.25	17-20	32.00	2.20	4.40	3.00	8	15.00	8.40	7.70	●
SD D32-M1.25-N04-SP15	1.25	21-25	32.00	2.20	4.40	3.00	8	15.00	8.40	7.70	●
SD D32-M1.50-N05-SP15	1.50	26-34	32.00	2.20	4.40	3.50	8	15.00	8.40	7.70	●
SD D32-M1.50-N06-SP15	1.50	35-54	32.00	2.20	4.40	3.50	8	15.00	8.40	7.70	●
SD D32-M1.75-N06-SP15	1.75	35-54	32.00	2.70	5.40	4.25	8	15.00	8.40	7.70	●
SD D32-M1.75-N07-SP15	1.75	55-134	32.00	2.70	5.40	4.25	8	15.00	8.40	7.70	●
SD D32-M1.75-N08-SP15	1.75	>134	32.00	2.70	5.40	4.25	8	15.00	8.40	7.70	●
SD D32-M2.00-N04-SP15	2.00	21-25	32.00	3.20	6.40	4.50	8	15.00	8.40	7.70	●
SD D32-M2.00-N05-SP15	2.00	26-34	32.00	3.20	6.40	4.50	8	15.00	8.40	7.70	●
SD D32-M2.00-N06-SP15	2.00	35-54	32.00	3.20	6.40	4.50	8	15.00	8.40	7.70	●
SD D32-M2.25-N06-SP15	2.25	35-54	32.00	3.20	6.40	5.00	8	15.00	8.40	7.70	●
SD D32-M2.25-N07-SP15	2.25	55-134	32.00	3.20	6.40	5.00	8	15.00	8.40	7.70	●
SD D32-M2.50-N06-SP15	2.50	35-54	32.00	3.70	7.40	5.50	8	15.00	8.40	7.70	●

• Tightening torque 4 Nxm • For user guide, see pages 9,12-13 • For shanks, see pages 79-87
⁽¹⁾ Gear teeth range
⁽²⁾ Number of cutting edges

Exchangeable Heads with Indexable Inserts

SELF-GRIP MULTI-MASTER

SGSF/A-MM-JHP
Grooving and Slitting Small Diameter Cutters with the MULTI-MASTER Threaded Adaptor

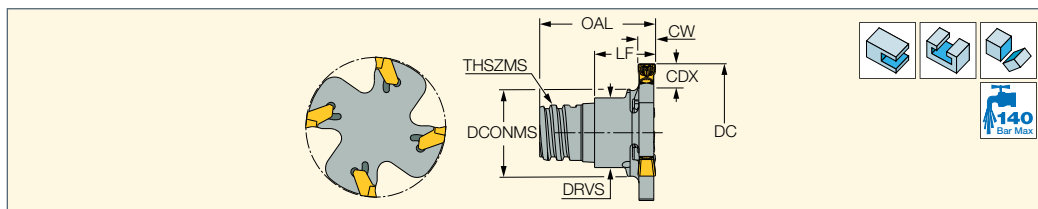

Designation	DC	CW	CDX	CICT ⁽¹⁾	DCONMS	THSZMS	LF	OAL	DRVS ⁽²⁾	Insert	
SGSF 32-2-MMT08-3Z-JHP	32.00	2.00	9.00	3	11.70	T08	10.60	18.10	10.0	GSFN 2...	ESG 1.4-2*
SGSA 32-3-MMT08-4Z-JHP	32.00	3.00	9.00	4	11.70	T08	11.60	19.20	10.0	GSAN 3...	ESG 1.4-2*
SGSF 40-2-MMT10-4Z-JHP	40.00	2.00	11.30	4	15.30	T10	10.60	21.90	13.0	GSFN 2...	ESG 1.4-2*
SGSA 40-3-MMT10-6Z-JHP	40.00	3.00	11.30	6	15.30	T10	11.40	22.70	13.0	GSAN 3...	ESG 1.4-2*

• For best performance use internal coolant with "CH" type shanks

⁽¹⁾ Number of inserts

⁽²⁾ Torque key size

* Optional, to be ordered separately

For inserts: GSAN • GSFN • GSFU

For holders, see pages: MM CAB (86) • MM CAB-T-T (86) • MM CAB-T-T-W (86) • MM GRT (shanks) (81) • MM S-A (stepped shanks) (79)

• MM S-A (straight shanks) (82) • MM S-A-C# (85) • MM S-A-HSK (85) • MM S-A-N (81) • MM S-A-SK (85) • MM S-B (85° conical shanks) (82)

• MM S-D (89° conical shanks) (83) • MM S-ER (84) • MM S-ER-H (84) • MM TS-A (81)

TANGSLIT MULTI-MASTER

TGSF-MM-JHP
Grooving and Slitting Small Diameter Cutters with MULTI-MASTER Threaded Adaptor

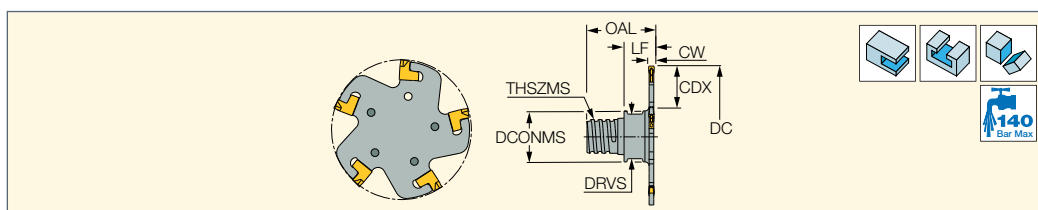

Designation	DC	CW	CDX	CICT ⁽¹⁾	DCONMS	THSZMS	LF	OAL	DRVS ⁽²⁾	Insert	
TGSF 50-2-MMT12-5Z-JHP	50.00	2.00	14.00	5	19.00	T12	10.70	24.00	16.0	TAG 2	ETG 2*
TGSF 50-3-MMT12-5Z-JHP	50.00	3.00	14.00	5	19.00	T12	11.50	24.70	16.0	TAG 3	ETG 3-4-SH*

• For best performance use internal coolant with "CH" type shanks

⁽¹⁾ Number of inserts

⁽²⁾ Torque key size

* Optional, to be ordered separately

For inserts: TAG N-A • TAG N-C/W/M • TAG N-HF • TAG N-J/JS/JT • TAG N-MF

For holders, see pages: MM CAB-T-T (86) • MM CAB-T-T-W (86) • MM S-A (stepped shanks) (79) • MM S-A (straight shanks) (82)

• MM S-A-C# (85) • MM S-A-HSK (85) • MM S-A-SK (85) • MM S-B (85° conical shanks) (82) • MM S-D (89° conical shanks) (83)

• MM S-ER (84) • MM S-ER-H (84) • MM TS-A (81)

MINI-TANGSLOT MULTI-MASTER

ETS-LN08-MM
Grooving and Slitting Cutters with MULTI-MASTER Threaded Adaptor

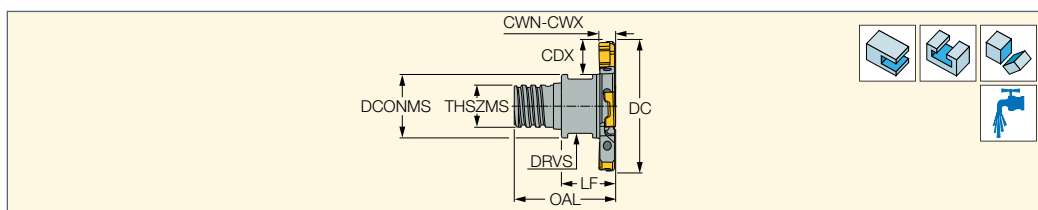

Designation	DC	CWN ⁽¹⁾	CWX ⁽²⁾	CDX ⁽³⁾	NOF ⁽⁴⁾	ZEP	DCONMS	THSZMS	LF	OAL	DRVS ⁽⁵⁾
ETS D32/1.26-4-LN08-MMT10	32.00	4.00 ⁽⁶⁾	4.50 ⁽⁷⁾	8.20	4	2	15.20	T10	13.00	24.30	13.0
ETS D40/1.57-4-LN08-MMT12	40.00	4.00 ⁽⁶⁾	4.50 ⁽⁷⁾	10.40	6	3	18.20	T12	13.00	26.30	16.0

• For user guide, see pages 9-11

⁽¹⁾ Minimum cutting width

⁽²⁾ Maximum cutting width

⁽³⁾ Cutting depth maximum

⁽⁴⁾ Number of flutes

⁽⁵⁾ Torque key size

⁽⁶⁾ Use LNET 0826.. insert with SR 114-018-L3.40 screw

⁽⁷⁾ Use LNET 0828.. insert with SR 114-018-L3.40 screw

For inserts: LNET 08

For holders, see pages: MM S-A (stepped shanks) (79) • MM S-A (straight shanks) (82) • MM S-A-C# (85) • MM S-A-HSK (85)

• MM S-A-N (81) • MM S-A-SK (85) • MM S-B (85° conical shanks) (82) • MM S-D (89° conical shanks) (83) • MM S-ER (84) • MM S-ER-H (84) • MM TS-A (81)

Spare Parts

Designation			
ETS-LN08-MM	SR 114-018-L3.40	T-6/5	T-6/3-L

THREAD MILLING



Exchangeable Solid Carbide Head

Identification Code

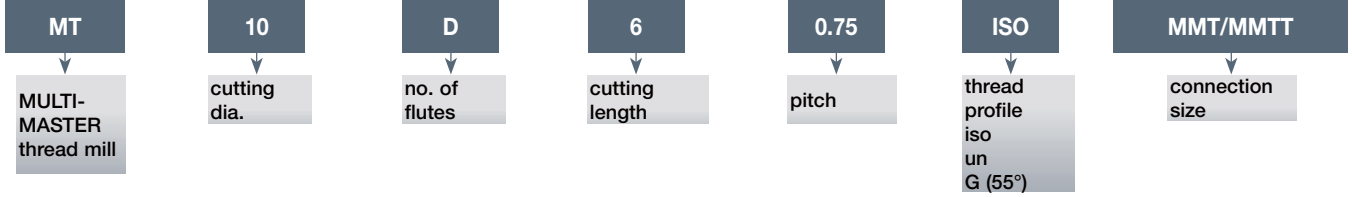

SOLIDTHREAD
MULTI-MASTER
INDEXABLE SOLID CARBIDE LINE

MT-ISO-MM
Carbide Milling Heads with a Threaded Connection for Internal ISO Metric Thread

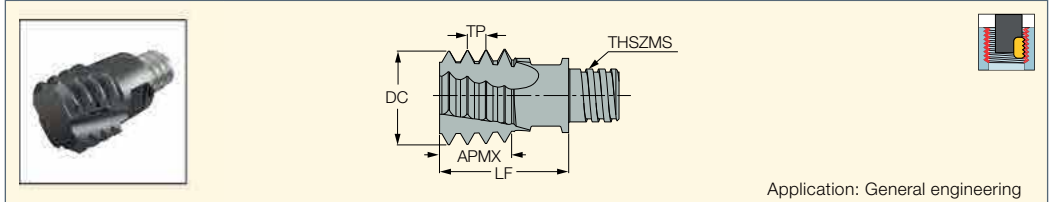

Application: General engineering

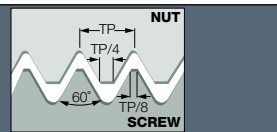

Dimensions

Designation	TP ⁽¹⁾	M Coarse	M Fine	DC	NOF ⁽²⁾	APMX	LF	THSZMS	IC908
MT10D7.5 0.5ISO-MMT05	0.500	-	=>14	10.00	4	7.50	12.75	T05	●
MT 10D6 0.75ISO-MMT05	0.750	-	=>12	10.00	4	6.00	12.75	T05	●
MT 10D6 1.0ISO-MMT05	1.000	-	=>12	10.00	4	6.00	12.75	T05	●
MT 10D5 1.25ISO-MMT05	1.250	-	=>14	10.00	4	5.00	12.75	T05	●
MT 10D6 1.5ISO-MMT05	1.500	-	=>14	10.00	4	6.00	12.75	T05	●
MT 12D8 0.5ISO-MMT06	0.500	-	=>16	12.00	4	8.00	14.30	T06	●
MT 12E8 0.75ISO-MMT06	0.750	-	=>16	12.00	5	8.30	14.30	T06	●
MT 12E8 1.0ISO-MMT06	1.000	-	=>16	12.00	5	8.00	14.30	T06	●
MT 12D8 1.25ISO-MMT06	1.250	-	=>16	12.00	4	7.50	14.30	T06	●
MT 12D7 1.5ISO-MMT06	1.500	-	=>16	12.00	4	7.60	14.30	T06	●
MT 12D7 1.75ISO-MMT06	1.750	-	=>16	12.00	4	7.10	14.30	T06	●
MT12D8 2.0ISO-MMT06	2.000	M16	=>17	12.00	4	8.00	14.30	T06	●
MT 16F12 1.0ISO-MMT08	1.000	-	=>22	16.00	6	12.00	20.00	T08	●
MT 16F12 1.5ISO-MMT08	1.500	-	=>20	16.00	6	12.00	20.00	T08	●
MT 16E12 2.0ISO-MMT08	2.000	-	=>19	16.00	5	12.00	20.00	T08	●
MT15.4E13 2.5ISO-MMT08	2.500	M20	=>22	15.40	5	12.70	20.00	T08	●
MT 16C12 3.0ISO-MMT08	3.000	M24	=>25	16.00	3	12.10	20.00	T08	●
MT20F14 2.0ISO-MMTT10	2.000	-	=>27	20.00	6	12.00	21.00	T10	●
MT20D12 3.0ISO-MMTT10	3.000	-	=>27	20.00	4	12.20	21.00	T10	●
MT20D14 3.5ISO-MMTT10	3.500	-	=>30	20.00	4	10.60	21.00	T10	●

• Note: Description and dimensions relate to the new products with clamping flats. • For shanks, see pages 79-86
 • For clamping keys (to be ordered separately), tightening torques and clamping instructions, see pages 10-11 • Do not apply lubricant to the threaded connection
⁽¹⁾ Thread pitch
⁽²⁾ Number of flutes

MT-UN-MM

Carbide Milling Heads with a Threaded Connection for Internal UN Thread Profile

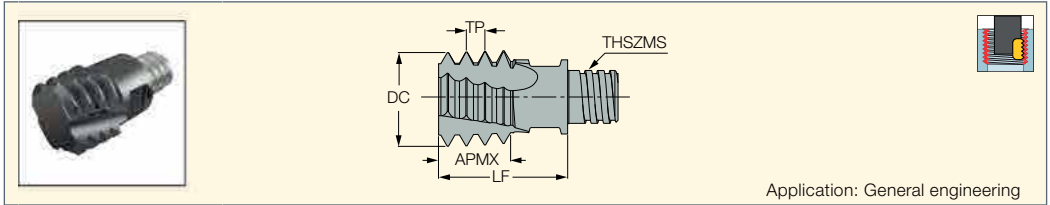

Application: General engineering

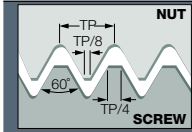

Designation	Dimensions										IC908
	TP ⁽¹⁾	UNC	UNF	UNEF	DC	NOF ⁽²⁾	APMX	LF	THSZMS	TP ⁽³⁾	
MT 10D7 32UN-MMT05	32.0	-	-	-	10.00	4	6.40	12.75	T05	0.794	●
MT 10D6 28UN-MMT05	28.0	-	1/2	-	10.00	4	5.50	12.75	T05	0.907	●
MT 10D6 24UN-MMT05	24.0	-	-	9/16-5/8	10.00	4	5.30	12.75	T05	1.058	●
MT 10D6 20UN-MMT05	20.0	-	1/2	-	10.00	4	5.10	12.75	T05	1.270	●
MT 10D5 18UN-MMT05	18.0	-	9/16-5/8	1 1/8-1 5/8	10.00	4	5.60	12.75	T05	1.411	●
MT 10D7 16UN-MMT05	16.0	-	3/4	-	10.00	4	6.40	12.75	T05	1.588	●
MT 12D8 24UN-MMT06	24.0	-	-	5/8- 11/16	12.00	4	7.40	14.30	T06	1.058	●
MT 12D8 20UN-MMT06	20.0	-	-	3/4 - 1	12.00	4	7.70	14.30	T06	1.270	●
MT 12D8 18UN-MMT06	18.0	-	5/8	=>1 11/16	12.00	4	7.10	14.30	T06	1.411	●
MT 12D8 16UN-MMT06	16.0	-	3/4	-	12.00	4	8.00	14.30	T06	1.588	●
MT 12D8 14UN-MMT06	14.0	-	7/8	-	12.00	4	7.30	14.30	T06	1.814	●
MT 16E11 18UN-MMT08	18.0	-	5/8	=>1 11/16	16.00	5	11.30	20.00	T08	1.411	●
MT 16E13 14UN-MMT08	14.0	-	7/8	-	16.00	5	12.70	20.00	T08	1.814	●
MT 16E13 12UN-MMT08	12.0	-	1-1 1/2	-	16.00	5	12.70	20.00	T08	2.117	●
MT 15.3D13 10UN-MMT08	10.0	3/4	-	-	15.30	4	12.70	20.00	T08	2.540	●
MT 16C11 9UN-MMT08	9.0	7/8	-	-	16.00	3	11.30	20.00	T08	2.822	●
MT 16C13 8UN-MMT08	8.0	1.0	-	-	16.00	3	12.70	20.00	T08	3.175	●
MT20F13 12UN-MMTT10	12.0	-	=>1	-	20.00	6	12.70	21.00	T10	2.117	●
MT20D13 8UN-MMTT10	8.0	1	-	-	20.00	4	12.70	21.00	T10	3.175	●
MT20D15 7UN-MMTT10	7.0	-	1 1/8 - 1 1/4	-	20.00	4	10.90	21.00	T10	3.629	●

- Note: Description and dimensions relate to the new products with clamping flats
- For shanks, see pages 79-86
- For clamping keys (to be ordered separately), tightening torques and clamping instructions, see pages 10-11
- Do not apply lubricant to the threaded connection

⁽¹⁾ Threads per inch

⁽²⁾ Number of flutes

⁽³⁾ Thread pitch



SOLIDTHREAD
MULTI-MASTER
INDEXABLE SOLID CARBIDE LINE

MT-W-MM
Carbide Milling Heads with a Threaded Connection for Internal and External 55° BSW Thread Profile

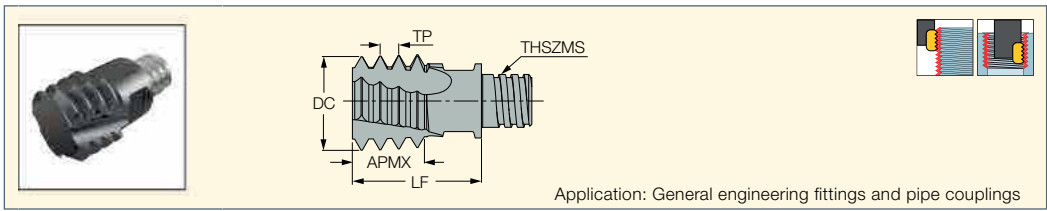

Application: General engineering fittings and pipe couplings

Designation	Dimensions								IC908
	TPI ⁽¹⁾	TDZ	DC	NOF ⁽²⁾	APMX	LF	THSZMS	TP ⁽³⁾	
MT 10D6 19W-MMT05	19.0	G1/4-3/8	10.00	4	5.30	12.75	T05	1.337	●
MT 16D13 14W-MMT08	14.0	G1/2-7/8	16.00	4	12.70	20.00	T08	1.814	●
MT 16D11 11W-MMT08	11.0	G>1	16.00	4	11.50	20.00	T08	2.309	●
MT20F15 14W-MMTT10	14.0	G3/4-7/8	20.00	6	12.70	21.00	T10	1.814	●
MT20F14 11W-MMTT10	11.0	G>1	20.00	6	11.50	21.00	T10	2.309	●

- Note: Description and dimensions relate to the new products with clamping flats
- For shanks, see pages 79-86
- For clamping keys (to be ordered separately), tightening torques and clamping instructions, see pages 10-11
- Do not apply lubricant to the threaded connection
- B.S.84 Internal & External tolerance: Medium class

⁽¹⁾ Threads per inch
⁽²⁾ Number of flutes
⁽³⁾ Thread pitch

Thread Size	Key ⁽¹⁾	Torque Wrench ⁽¹⁾	Wrench ⁽¹⁾	Tightening Torque (N×cm)
T05	MM KEY 6x4	TORQUE WRENCH 5-50Nm 9X12	MM WRENCH 6-05	700
T06	MM KEY 8x5	TORQUE WRENCH 5-50Nm 9X12	MM WRENCH 8-06	1000
T08	MM KEY 10x7	TORQUE WRENCH 5-50Nm 9X12	MM WRENCH 10-08	1500
T10	MM KEY 13x8	TORQUE WRENCH 5-50Nm 9X12	MM WRENCH 13-10	2800

⁽¹⁾ Order separately

SOLIDTHREAD
MULTI-MASTER
INDEXABLE SOLID CARBIDE LINE

MM TRD-M
Interchangeable Solid Carbide Milling Heads for 60° Partial Profile Thread Milling

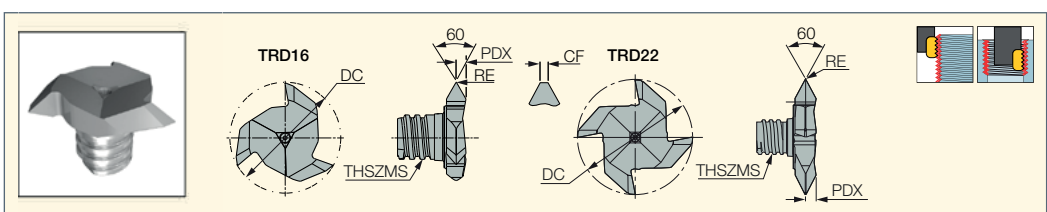

Designation	Dimensions														Tough Hard			
	DC	NOF ⁽¹⁾	TPN ⁽²⁾	TPX ⁽³⁾	DF2 ⁽⁴⁾	DF2 ⁽⁵⁾	TPIN ⁽⁶⁾	TPIX ⁽⁷⁾	DF2 ⁽⁸⁾	DF2 ⁽⁹⁾	RE	CF	PDX	THSZMS	TDZ ⁽¹⁰⁾	DMIN	IC528	IC908
MM TRD16-M60-05P-3T06	15.70	3	0.500	2.000	0.400	2.000	13.00	48.00	16.00	56.00	- ⁽¹¹⁾	0.05	1.4	T06	M20	19.05	●	●
MM TRD16-M60-15P-3T06	15.70	3	1.500	2.000	1.000	1.500	13.00	16.00	16.00	28.00	0.05	-	1.4	T06	M22	19.05	●	●
MM TRD22-M60-30P-4T08	21.70	4	3.000	4.500	2.500	4.000	6.00	9.00	7.00	10.00	0.20	-	2.4	T08	M36	31.00	●	●

- For ISO metric thread (ISO 68, DIN13, ANSI B 1.13M-1983)
- For shanks, see pages 79-86
- For clamping instructions, see pages 10-11
- Do not apply lubricant to the threaded connection.
- DIN13, ISO 68-1, ISO 965 (1&2) - Internal tolerance: 6H, External tolerance: 6g
- ANSI/ASME B1.1 - Internal tolerance: 2B, External tolerance: 2A

⁽¹⁾ Number of flutes
⁽²⁾ Thread pitch minimum (mm)-internal
⁽³⁾ Thread pitch maximum (mm)-internal
⁽⁴⁾ Thread pitch minimum (mm)-external
⁽⁵⁾ Thread pitch maximum (mm)-external
⁽⁶⁾ Threads per inch minimum-internal
⁽⁷⁾ Threads per inch maximum-internal
⁽⁸⁾ Threads per inch minimum-external
⁽⁹⁾ Threads per inch maximum-external
⁽¹⁰⁾ Smallest possible thread
⁽¹¹⁾ Flat

Spare Parts

Designation		
MM TRD16-M60-05P-3T06	MM EGR 16-18*	T-25/3*
MM TRD16-M60-15P-3T06	MM EGR 16-18*	T-25/3*
MM TRD22-M60-30P-4T08	MM EGR 20-22*	T-30/3 L*

* Optional, to be ordered separately

SOLIDTHREAD

MULTI-MASTER INDEXABLE SOLID CARBIDE LINE

MM TRD-W

Interchangeable Solid Carbide
Milling Heads for 55° Partial
Profile Thread Milling

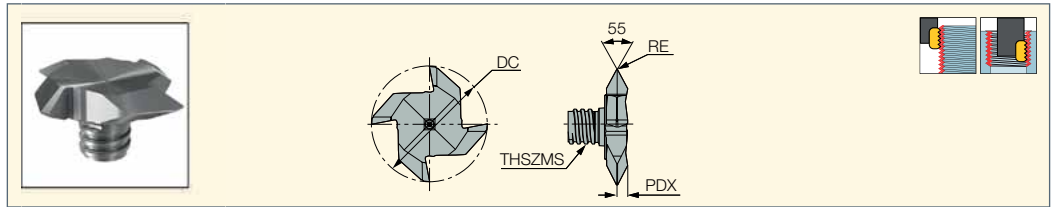



Designation	Dimensions											Tough ↔ Hard		
	DC	NOF ⁽¹⁾	RE	PDX	TPIN ⁽²⁾	TPIX ⁽³⁾	DF2 ⁽⁴⁾	DF2 ⁽⁵⁾	THSZMS	TDZ ⁽⁶⁾	DMIN	Standard	IC528	IC908
MM TRD22-W55-14P-4T08	21.70	4	0.20	2.0	11.00	14.00	11.50	16.00	T08	G3/4	24.20	DIN ISO 228, B.S. 84	●	●

• For shanks, see pages 79-86 • For clamping instructions, see pages 10-11 • Do not apply lubricant to the threaded connection.

- (1) Number of flutes
- (2) Threads per inch minimum-internal
- (3) Threads per inch maximum-internal
- (4) Threads per inch minimum-external
- (5) Threads per inch maximum-external
- (6) Thread diameter size

Spare Parts

Designation		
MM TRD-W	T-30/3 L*	MM EGR 20-22*

* Optional, to be ordered separately

SOLIDTHREAD

MULTI-MASTER INDEXABLE SOLID CARBIDE LINE

MM TRF 55°

Interchangeable Solid Carbide
Milling Heads for 55° Partial
Profile Thread Milling

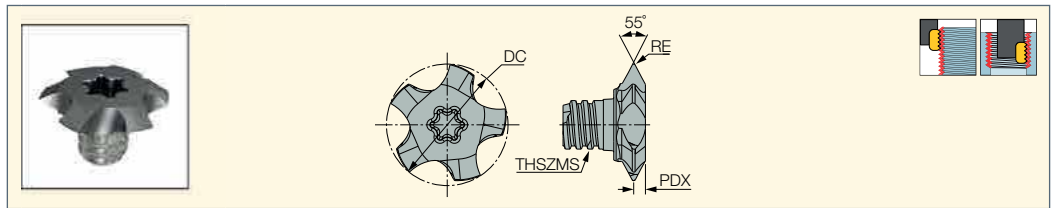

Designation	Dimensions										IC908
	DC	NOF ⁽¹⁾	TPIN ⁽²⁾	TPIX ⁽³⁾	RE	PDX	THSZMS	TDZ ⁽⁴⁾	DMIN	TQ ⁽⁵⁾	
MM TRF12-W55-P11-5T05	11.94	5	11.00	14.00	0.23	1.15	T05	15.875	13.60	7.0	●
MM TRF12-W55-P19-5T05	11.94	5	19.00	28.00	0.11	0.75	T05	14.287	13.10	10.0	●
MM TRF16-W55-P8-5T06	15.94	5	8.00	14.00	0.23	1.55	T06	20.637	18.30	15.0	●
MM TRF20-W55-P6-6T08	19.94	6	6.00	8.00	0.40	1.95	T08	25.4	21.30	28.0	●

• For ISO metric thread (ISO 68, DIN13, ANSI B 1.13M-1983) • For shanks, see pages 79-86 • For clamping instructions, see pages 10-11
• Do not apply lubricant to the threaded connection.

- (1) Number of flutes
- (2) Threads per inch minimum
- (3) Threads per inch maximum
- (4) Smallest possible thread
- (5) Tightening torque

Thread Size	Tightening Torque (NxcM)
T05	700
T06	1000
T08	1500
T10	2800

(1) Order separately

Spare Parts

Designation	
MM TRF12-W55-P11-5T05	BIT SOCKET T20 3/8" DRIVE*
MM TRF12-W55-P19-5T05	BIT SOCKET T20 3/8" DRIVE*
MM TRF16-W55-P8-5T06	BIT SOCKET T25 3/8" DRIVE*
MM TRF20-W55-P6-6T08	BIT SOCKET T40 3/8" DRIVE*

* Optional, to be ordered separately

SOLIDTHREAD
MULTI-MASTER
INDEXABLE SOLID CARBIDE LINE

MM TRF 60°
Interchangeable Solid Carbide
Milling Heads for 60° Partial
Profile Thread Milling

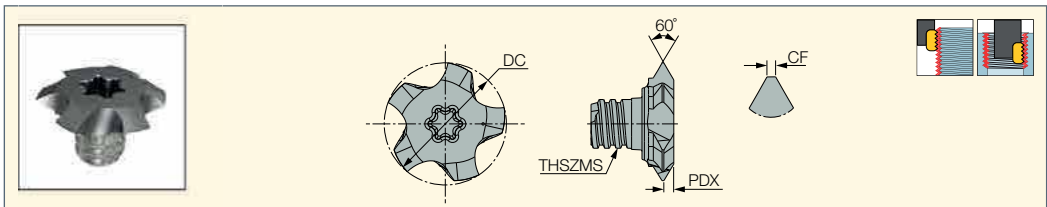

Designation	Dimensions																IC908
	DC	NOF ⁽¹⁾	TPN ⁽²⁾	TPX ⁽³⁾	TPN _{DF2} ⁽⁴⁾	TPX _{DF2} ⁽⁵⁾	TPIN ⁽⁶⁾	TPIX ⁽⁷⁾	TPN _{DF2} ⁽⁸⁾	TPIX _{DF2} ⁽⁹⁾	CF	PDX	THSZMS	TDZ ⁽¹⁰⁾	TQ	DMIN	
MM TRF12A60-P080-5T05	11.94	5	0.500	0.800	0.400	0.800	28.00	56.00	32.00	64.00	0.05	0.55	T05	M14	7.0	13.50	●
MM TRF12A60-P175-5T05	11.94	5	1.000	1.750	0.800	1.500	14.00	28.00	16.00	32.00	0.11	0.96	T05	M14	7.0	13.00	●
MM TRF12A60-P250-5T05	11.94	5	2.000	2.500	1.750	2.000	10.00	13.00	11.00	15.00	0.22	1.21	T05	M16	7.0	14.00	●
MM TRF16A60-P080-5T06	15.94	5	0.500	0.800	0.400	0.800	28.00	56.00	32.00	64.00	0.05	0.55	T06	M18	10.0	17.50	●
MM TRF16A60-P175-5T06	15.94	5	1.000	1.750	0.800	1.500	14.00	28.00	16.00	32.00	0.10	1.00	T06	M18	10.0	17.00	●
MM TRF16A60-P300-5T06	15.94	5	2.000	3.000	1.750	2.500	8.00	13.00	10.00	15.00	0.22	1.41	T06	M20	10.0	18.00	●
MM TRF20A60-P200-6T08	19.94	6	1.000	2.000	0.800	1.750	13.00	28.00	15.00	32.00	0.11	0.95	T08	M24	10.0	23.00	●
MM TRF20A60-P300-6T08	19.94	6	2.000	3.000	1.750	2.500	8.00	13.00	10.00	15.00	0.22	1.41	T08	M24	15.0	22.00	●
MM TRF20A60-P400-6T08	19.94	6	3.000	4.000	2.500	3.500	6.00	9.00	7.00	10.00	0.31	1.86	T08	M25	15.0	22.00	●
MM TRF28A60-P600-5T10	27.70	5	5.000	6.000	4.500	5.000	4.00	5.00	5.00	6.00	0.57	2.49	T10	M38	28.0	33.00	●
MM TRF28A60-P500-6T10	27.70	6	3.000	5.000	2.500	4.500	6.00	8.00	6.00	10.00	0.34	2.17	T10	M33	28.0	30.00	●

- For ISO metric thread (ISO 68, DIN13, ANSI B 1.13M-1983) • For shanks, see pages 79-86 • For clamping instructions, see pages 10-11
- Do not apply lubricant to the threaded connection.

- (1) Number of flutes
- (2) Thread pitch minimum (mm)-internal
- (3) Thread pitch maximum (mm)-internal
- (4) Thread pitch minimum (mm)-external
- (5) Thread pitch maximum (mm)-external
- (6) Threads per inch minimum-internal
- (7) Threads per inch maximum-internal
- (8) Threads per inch minimum-external
- (9) Threads per inch maximum-external
- (10) Smallest possible thread

Spare Parts

Designation	
MM TRF12A60-P080-5T05	BIT SOCKET T20 3/8" DRIVE*
MM TRF12A60-P175-5T05	BIT SOCKET T20 3/8" DRIVE*
MM TRF12A60-P250-5T05	BIT SOCKET T20 3/8" DRIVE*
MM TRF16A60-P080-5T06	BIT SOCKET T20 3/8" DRIVE*
MM TRF16A60-P175-5T06	BIT SOCKET T25 3/8" DRIVE*
MM TRF16A60-P300-5T06	BIT SOCKET T25 3/8" DRIVE*
MM TRF20A60-P200-6T08	BIT SOCKET T25 3/8" DRIVE*
MM TRF20A60-P300-6T08	BIT SOCKET T40 3/8" DRIVE*
MM TRF20A60-P400-6T08	BIT SOCKET T25 3/8" DRIVE*
MM TRF28A60-P600-5T10	BIT SOCKET T40 3/8" DRIVE*
MM TRF28A60-P500-6T10	BIT SOCKET T40 3/8" DRIVE*

* Optional, to be ordered separately



SOLIDTHREAD

SD TRD-M-SP
Interchangeable Solid Carbide Heads for 60° Partial Profile Thread Milling

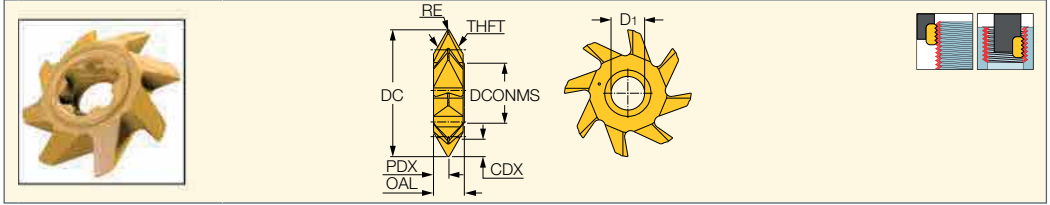

Designation	Dimensions															IC908
	DC	DMIN	DIOUT ⁽¹⁾	THFT ⁽²⁾	TPN ⁽³⁾	TPX ⁽⁴⁾	TPIN ⁽⁵⁾	TPIX ⁽⁶⁾	PDX	RE	D1	CDX	OAL	ZEFP ⁽⁷⁾	DCONMS	
SD TRD32-M60-6P-SP15	31.70	42.00	36.00	VP60	4.000	6.000	4.00	6.00	3.70	0.30	8.40	4.70	7.70	8	15.00	●
SD TRD40-M60-8P-SP17	39.70	57.00	64.00	VP60	6.000	8.000	3.00	4.00	4.50	0.40	9.80	6.20	9.50	10	17.00	●

- For shanks, see page 87 • For user guide, see pages 9,12-13 • DIN13 , ISO 68-1, ISO 965 (1&2) - Internal tolerance: 6H, External tolerance: 6g
- ANSI/ASME B1.1 - Internal tolerance: 2B, External tolerance: 2A

- (1) Minimum diameter for external threading
- (2) VP60=60° partial thread form
- (3) Thread pitch minimum (mm)
- (4) Thread pitch maximum (mm)
- (5) Threads per inch minimum
- (6) Threads per inch maximum
- (7) Num. of cutting edges

SOLIDTHREAD

SD TRD-W-SP
Interchangeable Solid Carbide Heads for 55° Partial Profile Thread Milling

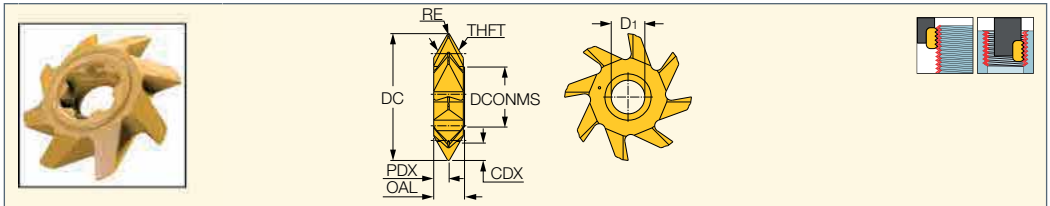

Designation	Dimensions														IC908
	DC	DMIN	DIOUT ⁽¹⁾	THFT ⁽²⁾	THFT_2	TPIN ⁽³⁾	TPIX ⁽⁴⁾	PDX	D1	CDX	OAL	ZEFP ⁽⁵⁾	RE	DCONMS	
SD TRD32-W55-4T-SP15	31.70	46.00	35.00	VP55	WH55	4.00	6.00	3.70	8.40	4.70	7.70	8	0.50	15.00	●
SD TRD40-W55-3T-SP17	39.70	57.00	57.00	VP55	WH55	3.00	4.00	4.50	9.80	6.20	9.50	10	0.80	17.00	●

- For shanks, see page 87 • For user guide, see pages 9,12-13 • B.S.84 Internal & External tolerance: Medium class

- (1) Minimum diameter for external threading
- (2) VP55=55° partial thread forms
- (3) Threads per inch minimum
- (4) Threads per inch maximum
- (5) Num. of cutting edges

Exchangeable Heads with Indexable Inserts

MILLTHREAD **MULTI-MASTER**

MTE-MM
Indexable Threading Endmills
with a MULTI-MASTER
Shank Connection

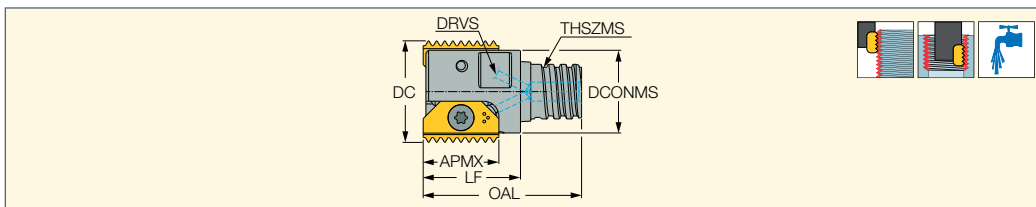

Designation	DC	APMX	CICT ⁽¹⁾	LF	THSZMS	DCONMS	OAL	DRVS ⁽²⁾	TQ ⁽³⁾	
MTE D13.7-1-MMT06-14	13.70	14.00	1	17.00	T06	9.60	23.30	8.0	1.2	0.03
MTE D15.8-1-MMT08-14	15.80	14.00	1	17.00	T08	11.70	24.50	10.0	1.2	0.02
MTE D20/D0.79-2-MMT10-14	20.00	14.00	2	18.00	T10	15.30	29.30	13.0	1.2	0.03
MTE D20/D0.79-3-MMT10-14	20.00	14.00	3	24.00	T10	15.30	35.30	13.0	1.2	0.02
MTE D21/D0.82-1-MMT10-21	21.00	21.00	1	25.00	T10	15.30	36.30	13.0	4.8	0.12
MTE D30.4/D1.2-2-MMT15-21	30.40	21.00	2	25.00	T15	23.90	42.00	20.0	4.8	0.13
MTE D30.4/D1.2-3-MMT15-21	30.40	21.00	3	34.00	T15	23.90	51.00	20.0	4.8	0.10
MTE D27-1-MMT12-30	27.00	30.00	1	38.20	T12	18.30	52.00	16.0	9.0	0.10

• Tool cutting diameter should not exceed 2/3 of thread bore diameter • For user guide, see pages 9-11

⁽¹⁾ Number of inserts

⁽²⁾ Torque key size

⁽³⁾ Recommended clamping torque

For inserts: MT LNH#-ACME (Internal) • MT LNH#-ISO (Internal) • MT LNH#-NPS • MT LNH#-NPSF • MT LNH#-UN (Internal) • MT LNH#-W
• MT LNHT-ABUT • MT LNHT-BSPT • MT LNHT-NPT • MT LNHT-NPTF • MT LNHU-ISO (External) • MT LNHU-NPSM (Internal) • MT LNHU-PG
• MT LNHU-UN (External) • MT LNHU-UNJ (External) • MT LNHU-UNJ (Internal)

For holders, see pages: MM CAB (86) • MM GRT (shanks) (81) • MM S-A (stepped shanks) (79) • MM S-A (straight shanks) (82) • MM S-A-C# (85) • MM S-A-HSK (85)
• MM S-A-N (81) • MM S-A-SK (85) • MM S-B (85° conical shanks) (82) • MM S-D (89° conical shanks) (83) • MM S-ER (84) • MM S-ER-H (84) • MM TS-A (81)

Spare Parts

Designation				
MTE D9.9-1-MMT05-12	SR M2.5-T8-MT	BLD T08/M7	SW4-SD	MM KEY 6X4*
MTE D13.7-1-MMT06-14	SR M2.6-L6.7-S11	BLD T08/M7	SW4-SD	MM KEY 8X5*
MTE D15.8-1-MMT08-14	SR M2.6-L6.7-S11	BLD T08/M7	SW4-SD	MM KEY 10X7*
MTE D20/D0.79-2-MMT10-14	SR M2.6-L6.7-S11	BLD T08/M7	SW4-SD	MM KEY 13X8*
MTE D20/D0.79-3-MMT10-14	SR M2.6-L6.7-S11	BLD T08/M7	SW4-SD	MM KEY 13X8*
MTE D21/D0.82-1-MMT10-21	SR M4-IP15-MT	BLD IP15/S7	SW6-SD	MM KEY 13X8*
MTE D30.4/D1.2-2-MMT15-21	SR M4-IP15-MT	BLD IP15/S7	SW6-SD	MM KEY 20*
MTE D30.4/D1.2-3-MMT15-21	SR M4-IP15-MT	BLD IP15/S7	SW6-SD	MM KEY 20*
MTE D27-1-MMT12-30	SR M5-IP25-MT-S	BLD IP25/S7	SW6-T	MM KEY 16X9*

* Optional, to be ordered separately

BLANKS

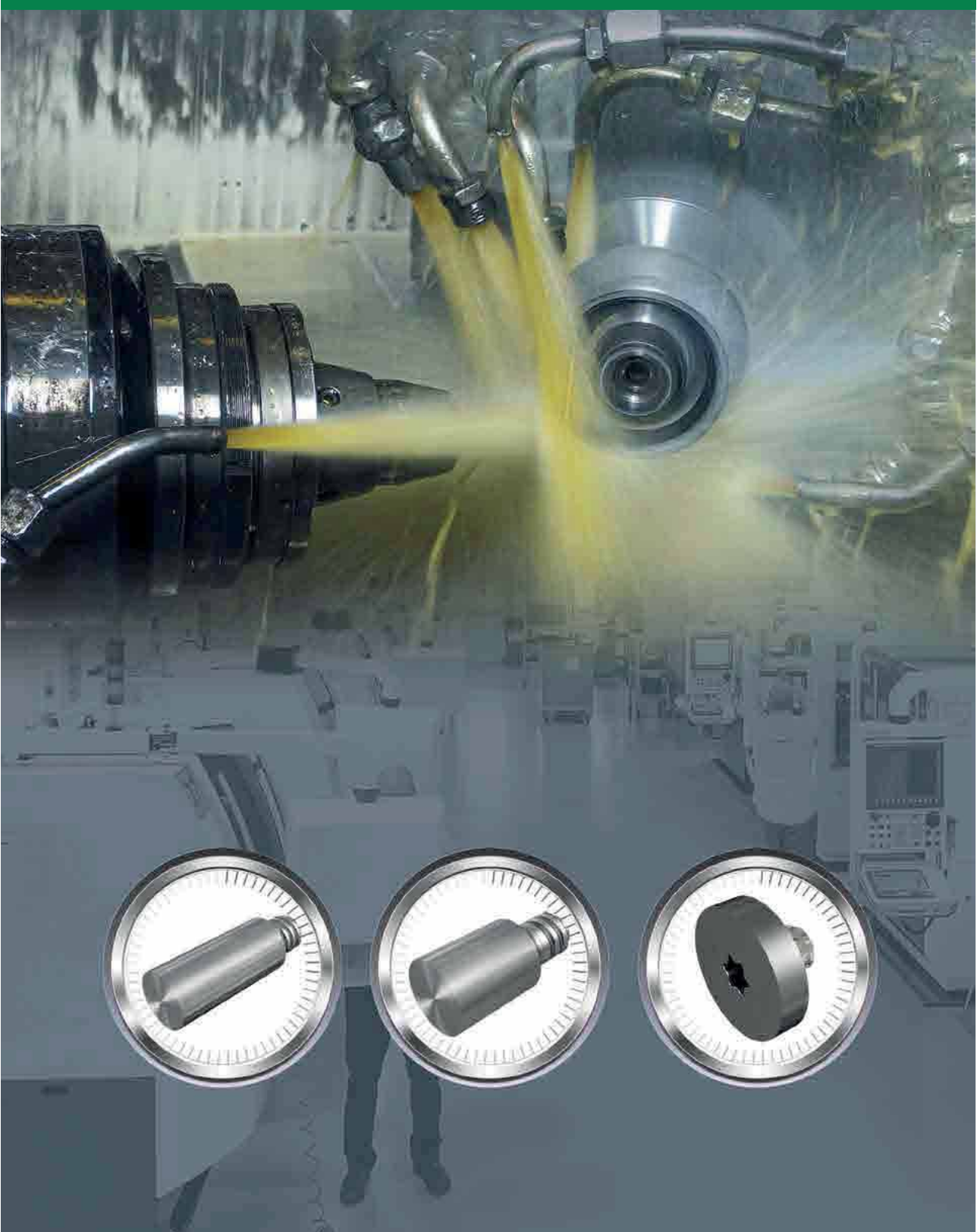

MM TC-G
Interchangeable Cemented Carbide Blank Heads

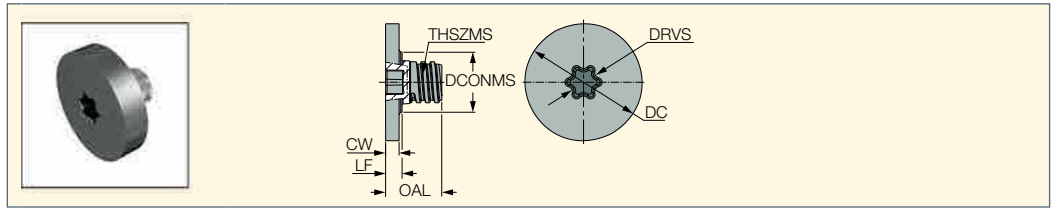

Designation	Dimensions							Tough ↔ Hard	
	DC	CW	LF	OAL	DCONMS	DRVS ⁽¹⁾	THSZMS	IC28	IC08
MM TC138N-19-G-T05	13.80	1.90	2.50	9.60	7.60	20.0	T05	●	
MM TC138N-23-G-T05	13.80	2.30	2.90	10.00	7.60	20.0	T05	●	
MM TC138N-28-G-T05	13.80	2.80	3.40	10.50	7.60	20.0	T05	●	
MM TC138N-35-G-T05	13.80	3.50	4.10	11.20	7.60	20.0	T05	●	
MM TC138N-43-G-T05	13.80	4.30	4.90	12.00	7.60	20.0	T05	●	
MM TC171N-19-G-T06	17.10	1.90	2.75	9.40	9.25	25.0	T06	●	
MM TC171N-23-G-T06	17.10	2.30	3.15	9.80	9.25	25.0	T06	●	
MM TC171N-33-G-T06	17.10	3.30	4.15	10.80	9.25	25.0	T06	●	
MM TC171N-43-G-T06	17.10	4.30	5.15	11.80	9.25	25.0	T06	●	
MM TC171N-50-G-T06	17.10	5.00	5.85	12.50	9.25	25.0	T06	●	
MM TC234N-27-G-T08	23.40	2.70	3.30	11.25	12.00	40.0	T08	●	
MM TC234N-42-G-T08	23.40	4.20	4.80	12.75	12.00	40.0	T08	●	
MM TC234N-53-G-T08	23.40	5.30	5.90	13.85	12.00	40.0	T08	●	
MM TC234N-66-G-T08	23.40	6.60	7.20	15.75	12.00	40.0	T08	●	
MM TC234N-82-G-T08	23.40	8.20	8.80	17.35	12.00	40.0	T08	●	
MM TC234N-99-G-T08	23.40	9.90	10.50	19.05	12.00	40.0	T08	●	
MM TC286N-28-G-T10	28.60	2.80	3.65	15.40	15.30	40.0	T10	●	
MM TC286N-36-G-T10	28.60	3.60	4.45	16.20	15.30	40.0	T10	●	
MM TC286N-46-G-T10	28.60	4.60	5.45	17.20	15.30	40.0	T10	●	
MM TC286N-56-G-T10	28.60	5.60	6.45	18.20	15.30	40.0	T10	●	●
MM TC286N-66-G-T10	28.60	6.60	7.45	19.20	15.30	40.0	T10	●	
MM TC286N-83-G-T10	28.60	8.30	9.15	20.90	15.30	40.0	T10	●	
MM TC286N-93-G-T10	28.60	9.30	10.15	21.90	15.30	40.0	T10	●	
MM TC286N-103-G-T10	28.60	10.30	11.15	22.90	15.30	40.0	T10	●	
MM TC356N-60-G-T12	35.60	6.00	6.55	20.35	18.30	50.0	T12	●	
MM TC356N-100-G-T12	35.60	10.00	10.55	24.35	18.30	50.0	T12	●	●
MM TC356N-120-G-T12	35.60	12.00	12.55	26.35	18.30	50.0	T12	●	
MM TC356N-160-G-T12	35.60	16.00	16.55	30.35	18.30	50.0	T12	●	

- For shanks, see pages 79-86
 - For tightening torques and clamping instructions, see pages 10-11
 - Do not apply lubricant to the threaded connection
 - For user guide, see pages 9,12-13
- ⁽¹⁾ Torque key size

MM ESR BLANKS
Interchangeable Solid Carbide Blank Heads

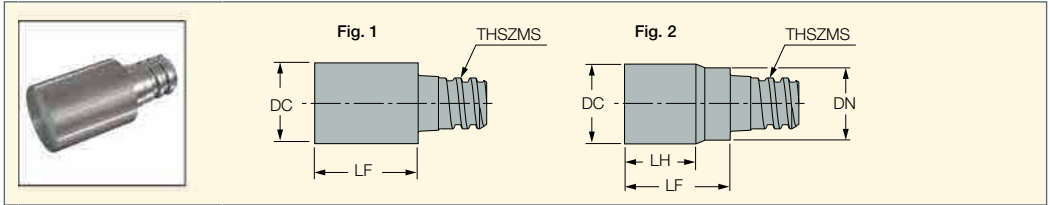

Designation	Dimensions						Tough ↔ Hard	
	DC	LF	THSZMS	LH	DN	Fig.	IC08	IC03
MM ESR-G 080-10 T05	8.00	10.35	T05	-	-	1	●	●
MM ESR-G 080-15 T05	8.00	15.40	T05	-	-	1	●	
MM ESR-G.375-.56T06	9.53	13.35	T06	-	-	1	●	
MM ESR-G.375-.75T06	9.53	19.40	T06	-	-	1	●	
MM ESR-G 100-13 T05	10.00	13.35	T05	-	-	1	●	
MM ESR-G 100-13 T06	10.00	13.35	T06	-	-	1	●	●
MM ESR-G 100-19 T06	10.00	19.45	T06	-	-	1	●	
MM ESR-G 120-17 T06	12.00	17.05	T06	-	-	1	●	
MM ESR-G 120-17 T08	12.00	17.05	T08	-	-	1	●	
MM ESR-G 120-23 T08	12.00	23.40	T08	-	-	1	●	
MM ESR-G.500-.67T06	12.70	17.09	T06	-	-	1	●	
MM ESR-G.500-.67T08	12.70	17.09	T08	-	-	1	●	●
MM ESR-G.500-.91T08	12.70	23.45	T08	-	-	1	●	
MM ESR-G.625-.83 T10	15.88	20.90	T10	-	-	1	●	
MM ESR-G 160-21 T08	16.00	20.90	T08	-	-	1	●	
MM ESR-G 160-21 T10	16.00	20.90	T10	-	-	1	●	●
MM ESR-G 160-28 T08	16.00	28.45	T08	-	-	1	●	
MM ESR-G 160-28 T10	16.00	28.45	T10	-	-	1	●	
MM ESR-G.750-1.02T12	19.05	26.05	T12	17.0	18.45	2	●	
MM ESR-G 200-26 T12	20.00	28.10	T12	16.6	18.45	2	●	●
MM ESR-G 200-34 T12	20.00	34.50	T12	-	-	1	●	
MM ESR-G 222-295 T12	22.00	29.50	T12	17.9	18.45	2	●	
MM ESR-G 222-295 T10	22.22	29.50	T10	17.9	18.45	2	●	
MM ESR-G 250-25 T15	25.00	25.60	T15	-	-	1	●	●
MM ESR-G 250-37 T12	25.00	37.60	T12	-	-	1	●	
MM ESR-G 250-37 T15	25.00	37.60	T15	-	-	1	●	
MM ESR-G 320-55-T21 NECK	32.00	55.80	T21	39.5	30.00	2	●	

MM ESR-1.5D BLANKS
Interchangeable Solid Carbide Blank Heads

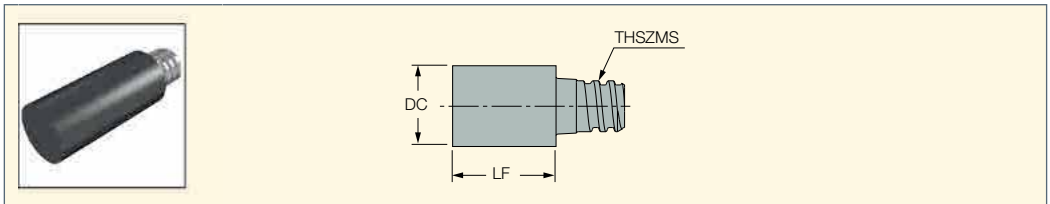

Designation	Dimensions			IC08
	DC	LF	THSZMS	
MM ESR-G 080-18.0 T05 08	8.00	18.40	T05	●
MM ESR-G.375-.87T06	9.53	22.40	T06	●
MM ESR-G 100-22.0 T06	10.00	22.40	T06	●
MM ESR-G 120-27.0 T08 08	12.00	27.45	T08	●
MM ESR-G.500-1.06T08	12.70	27.45	T08	●
MM ESR-G 160-33.5 T10	16.00	34.00	T10	●
MM ESR-G.750-1.61T12	19.05	41.50	T12	●
MM ESR-G 200-41.0 T12	20.00	41.50	T12	●
MM ESR-G 250-52.5 T15	25.00	53.00	T15	●
MM ESR-G1.00-2.07T15	25.40	53.00	T15	●

SHANKS



MULTI-MASTER

MM S-A (stepped shanks)
Stepped Cylindrical Shanks
Mount Interchangeable
Milling Heads

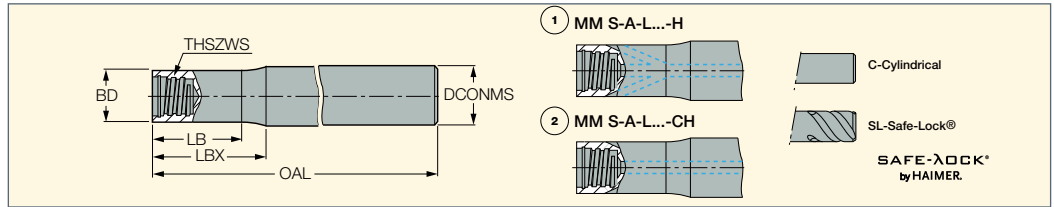

Designation	THSZWS	DCONMS	BD	LB	LBX	OAL	Shank ⁽¹⁾	Shank m. ⁽²⁾	CSP ⁽³⁾	Fig.	RPMX ⁽⁴⁾	Kg
MM S-A-L050-C08-T04	T04	8.00	5.80	9.90	14.0	50.00	C	S	0	-	60000	0.03
MM S-A-L060/20-C08-T04-C	T04	8.00	5.80	16.90	20.0	60.00	C	C	0	-	60000	0.03
MM S-A-L060-C08-T05	T05	8.00	7.60	12.50	15.0	60.00	C	S	0	-	60000	0.02
MM S-A-L065/24-SL08T05C	T05	8.00	7.60	24.00	25.6	65.00	SL	C	0	-	60000	0.04
MM S-A-L070-C08-T05-C	T05	8.00	7.60	18.60	20.0	70.00	C	C	0	-	60000	0.04
MM S-A-L070-C08-T05-W	T05	8.00	7.60	18.90	20.0	70.00	C	W	0	-	60000	0.06
MM S-A-L090-C08-T05-C	T05	8.00	7.60	38.60	40.0	90.00	C	C	0	-	50160	0.06
MM S-A-L090-C08-T05-W	T05	8.00	7.60	38.60	40.0	90.00	C	W	0	-	36090	0.07
MM S-A-L110-C08-T05-C	T05	8.00	7.60	57.90	60.0	110.00	C	C	0	-	30600	0.07
MM S-A-L110-C08-T05-W	T05	8.00	7.60	58.90	60.0	110.00	C	W	0	-	21060	0.09
MM S-A-L070-C10-T06-C	T06	10.00	9.60	18.50	20.0	70.00	C	C	0	-	54900	0.08
MM S-A-L070-C10-T06-W-H	T06	10.00	9.60	18.90	20.0	70.00	C	W	1	1	60000	0.08
MM S-A-L075-C10-T06	T06	10.00	9.60	17.70	20.0	75.00	C	S	0	-	60000	0.05
MM S-A-L075-C10-T06-H	T06	10.00	9.60	19.40	20.0	75.00	C	S	1	1	53940	0.04
MM S-A-L075/12-C10-T06-CH	T06	10.00	9.60	10.60	12.0	75.00	C	S	1	2	53940	0.04
MM S-A-L075/30-SL10T06C	T06	10.00	9.60	30.00	31.7	75.00	SL	C	0	-	53940	0.08
MM S-A-L090-C10-T06-C	T06	10.00	9.60	38.60	40.0	90.00	C	C	0	-	55170	0.06
MM S-A-L090/040C10T06C-H	T06	10.00	9.60	38.60	40.0	90.00	C	C	1	1	60000	0.08
MM S-A-L090-C10-T06-W	T06	10.00	9.60	17.20	20.0	90.00	C	W	0	-	41670	0.12
MM S-A-L090-C10-T06-W-H	T06	10.00	9.60	39.00	40.0	90.00	C	W	1	1	40860	0.10
MM S-A-L110-C10-T06-C	T06	10.00	9.60	57.90	60.0	110.00	C	C	0	-	34530	0.11
MM S-A-L110-C10-T06-W-H	T06	10.00	9.60	59.00	60.0	110.00	C	W	1	1	24840	0.12
MM S-A-L150-C10-T06-C	T06	10.00	9.60	98.50	100.0	150.00	C	C	0	-	16620	0.16
MM S-A-L070-C12-T08-C	T08	12.00	11.60	17.90	20.0	70.00	C	C	0	-	60000	0.10
MM S-A-L070-C12-T08-W-H	T08	12.00	11.60	18.70	20.0	70.00	C	W	1	1	60000	0.11
MM S-A-L085/36-C12T08C	T08	12.00	11.60	36.00	37.7	85.00	C	C	0	-	60000	0.13
MM S-A-L090/14-C12-T08-CH	T08	12.00	11.60	13.00	14.0	90.00	C	S	1	2	43000	0.08
MM S-A-L090-C12-T08	T08	12.00	11.60	13.30	16.0	90.00	C	S	0	-	43000	0.08
MM S-A-L070/020C12T08C-CH	T08	12.00	11.60	18.00	20.0	70.00	C	C	1	2	43050	0.08
MM S-A-L090-C12-T08-C	T08	12.00	11.60	39.00	40.0	90.00	C	C	0	-	43050	0.12
MM S-A-L090-C12-T08-H	T08	12.00	11.60	38.70	40.0	90.00	C	S	1	1	41040	0.08
MM S-A-L090-C12-T08-W-H	T08	12.00	11.60	38.70	40.0	90.00	C	W	1	1	49800	0.15
MM S-A-L090/040C12T08C-CH	T08	12.00	11.50	38.00	40.0	90.00	C	C	1	2	49800	0.11
MM S-A-L090/42-C12-T08-CH	T08	12.00	11.60	41.00	42.0	90.00	C	S	1	2	41010	0.07
MM S-A-L110-C12-T08-W	T08	12.00	11.60	17.00	20.0	110.00	C	W	0	-	31350	0.20
MM S-A-L110-C12-T08-C	T08	12.00	11.60	57.00	60.0	110.00	C	C	0	-	41040	0.16
MM S-A-L110-C12-T08-W-H	T08	12.00	11.60	58.70	60.0	110.00	C	W	1	1	30210	0.18
MM S-A-L110/060C12T08C-CH	T08	12.00	11.50	58.00	60.0	110.00	C	C	1	2	30210	0.12
MM S-A-L130-C12-T08-C	T08	12.00	11.60	78.60	80.0	130.00	C	C	0	-	27960	0.19
MM S-A-L130-C12-T08-W-H	T08	12.00	11.60	78.70	80.0	130.00	C	W	1	1	20100	0.21
MM S-A-L130/080C12T08C-CH	T08	12.00	11.50	78.00	80.0	130.00	C	C	1	2	20100	0.17
MM S-A-L070-C16-T10-W-H	T10	16.00	15.30	18.20	20.0	70.00	C	W	1	1	60000	0.21
MM S-A-L090-C16-T10-C	T10	16.00	15.30	38.00	40.0	90.00	C	C	0	-	60000	0.21
MM S-A-L090-C16-T10-W-H	T10	16.00	15.30	38.20	40.0	90.00	C	W	1	1	57510	0.27
MM S-A-L090/040C16T10C-CH	T10	16.00	15.30	38.00	40.0	90.00	C	C	1	2	57510	0.17
MM S-A-L100-C16-T10	T10	16.00	15.30	17.10	20.0	100.00	C	S	0	-	39000	0.15
MM S-A-L100-C16-T10-H	T10	16.00	15.30	48.00	50.0	100.00	C	S	1	1	37140	0.13
MM S-A-L100/20-C16-T10-CH	T10	16.00	15.30	18.00	20.0	100.00	C	S	1	2	37140	0.12
MM S-A-L100/42-C16-T10-CH	T10	16.00	15.30	40.20	42.0	100.00	C	S	1	2	38040	0.14
MM S-A-L100/48-C16T10C	T10	16.00	15.30	48.00	50.3	100.00	C	C	0	-	38040	0.06
MM S-A-L110-C16-T10-C	T10	16.00	15.30	58.20	60.0	110.00	C	C	0	-	47010	0.27
MM S-A-L110-C16-T10-W-H	T10	16.00	15.30	58.20	60.0	110.00	C	W	1	1	36030	0.33
MM S-A-L110/060C16T10C-H	T10	16.00	15.00	58.10	60.0	110.00	C	C	1	1	60000	0.24
MM S-A-L110/060C16T10C-CH	T10	16.00	15.30	58.00	60.0	110.00	C	C	1	2	36030	0.28
MM S-A-L130-C16-T10-C	T10	16.00	15.30	77.40	80.0	130.00	C	C	0	-	33510	0.32
MM S-A-L130-C16-T10-W-H	T10	16.00	15.30	78.20	80.0	130.00	C	W	1	1	24450	0.41
MM S-A-L130/080C16T10C-CH	T10	16.00	15.30	78.00	80.0	130.00	C	C	1	2	24450	0.32
MM S-A-L150-C16-T10-C	T10	16.00	15.30	97.40	100.0	150.00	C	C	0	-	24660	0.37
MM S-A-L150-C16-T10-W-H	T10	16.00	15.30	98.20	100.0	150.00	C	W	1	1	17610	0.45
MM S-A-L090-C20-T12-C	T12	20.00	18.30	37.20	40.0	90.00	C	C	0	-	60000	0.27
MM S-A-L090-C20-T12-W-H	T12	20.00	18.30	36.90	40.0	90.00	C	W	1	1	60000	0.41

- Do not apply lubricant to the threaded connection
- (2) C-Cylindrical, SL-Safe-Lock® by Haimer, helical grooves that prevent pull-out (available upon request).
- (3) S-steel, C-carbide, W-tungsten
- (4) 0 - Without coolant supply, 1 - With coolant supply
- (5) The maximum RPM must be calculated. Divide the listed max. RPM by the number of flutes (on the milling head) being used.

MULTI-MASTER**MM S-A (stepped shanks)**

Stepped Cylindrical Shanks
Mount Interchangeable
Milling Heads

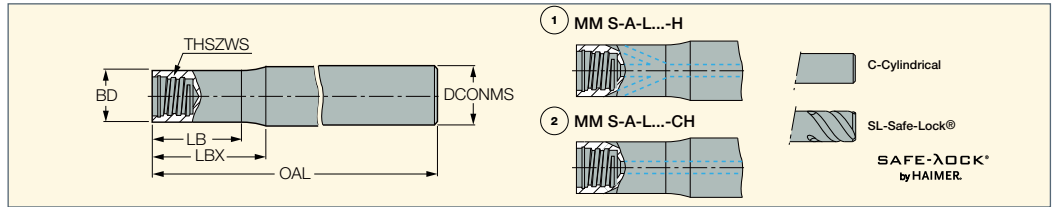

Designation	THSZWS	DCNOMS	BD	LB	LBX	OAL	Shank ⁽¹⁾	Shank m. ⁽²⁾	CSP ⁽³⁾	Fig.	RPMX ⁽⁴⁾	Kg
MM S-A-L090/040C20T12C-CH	T12	20.00	18.30	37.20	40.0	90.00	C	C	1	2	60000	0.30
MM S-A-L110/50-SL20T12C	T12	20.00	18.30	50.00	53.3	110.00	SL	C	0	-	60000	0.41
MM S-A-L120-C20-T12	T12	20.00	18.30	20.30	25.0	120.00	C	S	0	-	36000	0.27
MM S-A-L120-C20-T12-H	T12	20.00	18.30	66.70	70.0	120.00	C	S	1	1	32160	0.25
MM S-A-L120/25-C20-T12-CH	T12	20.00	18.30	22.20	25.0	120.00	C	S	1	2	32160	0.12
MM S-A-L120/48-C20-T12-CH	T12	20.00	18.30	45.20	48.0	120.00	C	S	1	2	32160	0.20
MM S-A-L130-C20-T12-C	T12	20.00	18.30	77.20	80.0	130.00	C	C	0	-	42360	0.47
MM S-A-L130-C20-T12-W-H	T12	20.00	18.30	76.90	80.0	130.00	C	W	1	1	31650	0.59
MM S-A-L130/080C20T12C-CH	T12	20.00	18.30	77.20	80.0	130.00	C	C	1	2	42360	0.44
MM S-A-L170-C20-T12-C	T12	20.00	18.30	97.20	100.0	170.00	C	C	0	-	25170	0.63
MM S-A-L200-C20-T12-C	T12	20.00	18.30	116.50	120.0	200.00	C	C	0	-	17790	0.76
MM S-A-L200-C20-T12-W-H	T12	20.00	18.30	116.90	120.0	200.00	C	W	1	1	12540	0.92
MM S-A-L200/120C20T12C-CH	T12	20.00	18.30	117.20	120.0	200.00	C	C	1	2	17790	0.74
MM S-A-L120-C25-T15-C	T15	25.00	23.90	57.50	60.0	120.00	C	C	0	-	49400	0.64
MM S-A-L120-C25-T15-W-H	T15	25.00	23.90	58.00	60.0	120.00	C	W	1	1	41700	0.89
MM S-A-L125/63-C25T15C	T15	25.00	24.00	63.00	65.8	125.00	C	C	0	-	41700	0.75
MM S-A-L135-C25-T15	T15	25.00	23.90	33.00	35.0	135.00	C	S	0	-	28290	0.47
MM S-A-L135/35-C25-T15-CH	T15	25.00	23.90	33.00	35.0	135.00	C	S	1	2	28230	0.42
MM S-A-L135/50-C25-T15-CH	T15	25.00	23.90	47.70	50.0	135.00	C	S	1	2	28230	0.40
MM S-A-L170-C25-T15-C	T15	25.00	23.90	98.00	100.0	170.00	C	C	0	-	27360	0.96
MM S-A-L175-C25-T15	T15	25.00	23.90	62.70	65.0	175.00	C	S	0	-	16890	0.10
MM S-A-L250-C25-T15-C	T15	25.00	23.90	148.00	150.0	250.00	C	C	0	-	12690	1.45
MM S-A-L100/32-C32-T21	T21	32.00	30.00	32.00	35.3	100.00	C	S	0	-	12690	0.56
MM S-A-L130/60-C32-T21-C	T21	32.00	30.00	60.00	63.3	130.00	C	C	0	-	12690	1.22
MM S-A-L135/64-C32T21C	T21	32.00	30.00	64.00	67.5	135.00	C	C	0	-	12690	1.02
MM S-A-L150/50-C32-T21	T21	32.00	30.00	50.00	53.5	150.00	C	S	0	-	12690	0.86
MM S-A-L170/100-C32-T21-C	T21	32.00	30.00	100.00	103.5	170.00	C	C	0	-	12690	1.22
MM S-A-L250/150-C32-T21-C	T21	32.00	30.00	150.00	153.5	250.00	C	C	0	-	12690	2.50
MM S-A-L300/200-C32-T21-C	T21	32.00	30.00	200.00	203.5	300.00	C	C	0	-	12690	3.00

• Do not apply lubricant to the threaded connection

⁽²⁾ C-Cylindrical, SL-Safe-Lock® by Haimer, helical grooves that prevent pull-out (available upon request).

⁽³⁾ S-steel, C-carbide, W-tungsten

⁽⁴⁾ 0 - Without coolant supply, 1 - With coolant supply

⁽⁵⁾ The maximum RPM must be calculated. Divide the listed max. RPM by the number of flutes (on the milling head) being used.



MULTI-MASTER

MM S-A-N

Stepped Cylindrical Shanks with Parallel Directed Coolant Mount Interchangeable Milling Heads

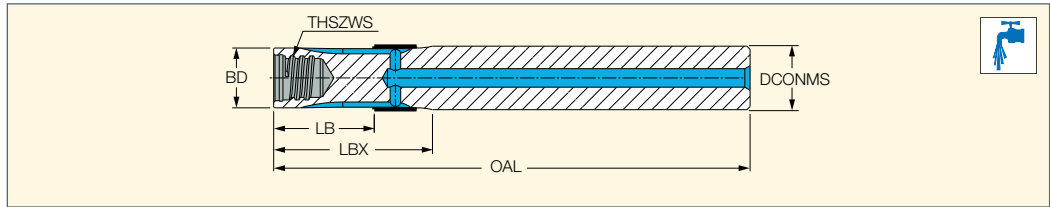

Designation	THSZWS	DCONMS	BD	LB	LBX	OAL	Shank m. ⁽¹⁾	kg
MM S-A-L075-C10-T06-N	T06	10.00	9.60	18.00	28.0	75.00	S	0.04
MM S-A-L090-C12-T08-N	T08	12.00	11.60	18.00	30.0	90.00	S	0.07
MM S-A-L100-C16-T10-N	T10	16.00	15.30	23.00	35.0	100.00	S	0.04

• Do not apply lubricant to the threaded connection

⁽¹⁾ S-steel

MULTI-MASTER

MM TS-A

Cylindrical Shanks Mount Interchangeable Milling Heads

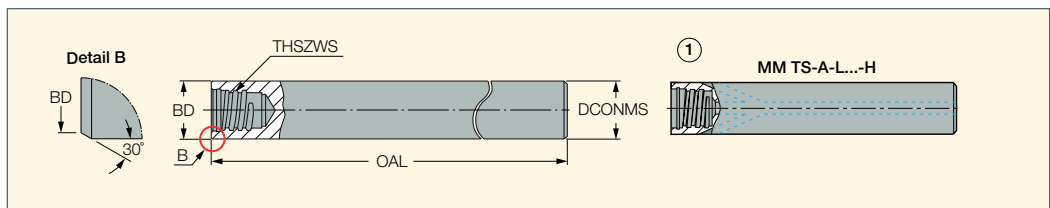

Designation	THSZWS	DCONMS	BD	OAL	Shank m. ⁽¹⁾	RPMX ⁽²⁾	CSP ⁽³⁾	Fig.	kg
MM TS-A-L070-C08-T04	T04	8.00	5.80	70.00	S	-	0	-	0.03
MM TS-A-L070-C08-T05	T05	8.00	7.60	70.00	S	60000	0	-	0.03
MM TS-A-L080-C10-T06	T06	10.00	9.60	80.00	S	47400	0	-	0.05
MM TS-A-L080-C10-T06-H	T06	10.00	9.60	80.00	S	46920	1	1	0.04
MM TS-A-L090-C12-T08	T08	12.00	11.60	90.00	S	43110	0	-	0.08
MM TS-A-L090-C12-T08-H	T08	12.00	11.60	90.00	S	42780	1	1	0.08
MM TS-A-L100-C16-T10	T10	16.00	15.30	100.00	S	39420	0	-	0.16
MM TS-A-L100-C16-T10-H	T10	16.00	15.30	100.00	S	39210	1	1	0.14

• Do not apply lubricant to the threaded connection

⁽¹⁾ S-steel

⁽²⁾ The actual maximum RPM to be calculated by dividing the listed RPM max by the number of the head's flutes being used.

⁽³⁾ 0 - Without coolant supply, 1 - With coolant supply

MULTI-MASTER

MM GRT (shanks)

Mount Slitting and Grooving Interchangeable Milling Heads

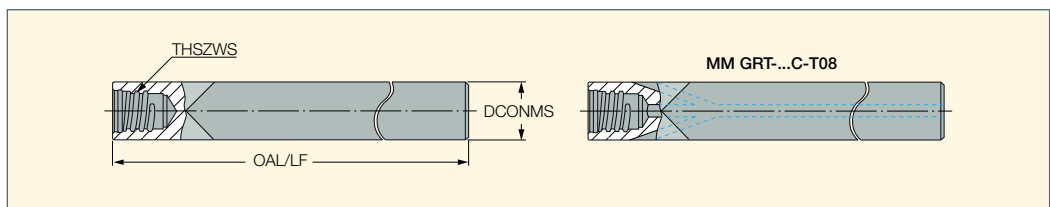

Designation	THSZWS	DCONMS	OAL	Shank m. ⁽¹⁾	CSP ⁽²⁾	kg
MM GRT-095-T06	T06	9.52	80.00	C	0	0.07
MM GRT-100-T06	T06	10.00	100.00	C	0	0.10
MM GRT-120C-T08	T08	12.00	100.00	C	1	0.12
MM GRT-127C-T08	T08	12.70	120.00	C	1	0.17

• MM GRT... shanks serve mainly for MM GRIT... slitting heads.

When mounting other types of milling heads, do not exceed maximum specified depth of cut for the particular milling head.

Since the shank diameter is not relieved, it may touch a wall on the workpiece being machined.

• Use carbide shanks for groove milling heads and for applications requiring high rigidity and processes.

⁽¹⁾ C - Solid carbide

⁽²⁾ 0 - Without coolant supply, 1 - With coolant supply

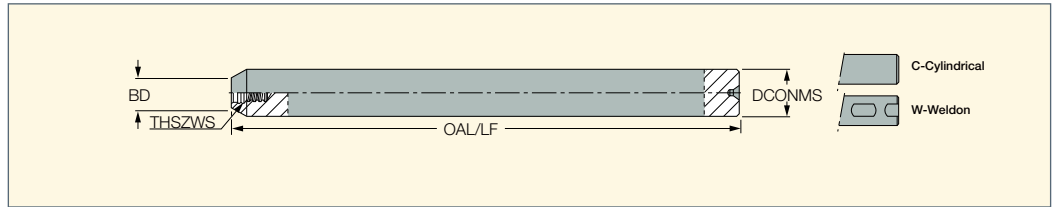
MULTI-MASTER**MM S-A (straight shanks)**
Shanks Mount Interchangeable
Milling Heads

Designation	THSZWS	DCONMS	BD	OAL	Shank ⁽²⁾	Shank m. ⁽³⁾	RPMX ⁽⁴⁾	kg
MM S-A-L055-W12-T05	T05	12.00	7.60	55.00	W	S	60000	0.05
MM S-A-L070-C20T05	T05	20.00	7.60	70.00	C	S	60000	0.24
MM S-A-L150-C12-T05-B ⁽¹⁾	T05	12.00	7.60	150.00	C	S	18270	0.13
MM S-A-L065-W16-T06	T06	16.00	9.60	65.00	W	S	60000	0.09
MM S-A-L080-C25T06	T06	25.00	9.60	80.00	C	S	60000	0.29
MM S-A-L200-C16-T06-B ⁽¹⁾	T06	16.00	9.60	200.00	C	S	11970	0.33
MM S-A-L065-W16-T08	T08	16.00	11.60	65.00	W	S	60000	0.10
MM S-A-L080-C25T08	T08	25.00	11.60	80.00	C	S	60000	0.40
MM S-A-L250-C20-T08-B ⁽¹⁾	T08	20.00	11.60	250.00	C	S	9330	0.60
MM S-A-L070-W20-T10	T10	20.00	15.30	70.00	W	S	60000	0.17
MM S-A-L080-C32T10	T10	32.00	15.30	80.00	C	S	60000	0.65
MM S-A-L250-C25-T10-B ⁽¹⁾	T10	25.00	15.30	250.00	C	S	11130	0.94
MM S-A-L075-W25-T12	T12	25.00	18.30	75.00	W	S	60000	0.28
MM S-A-L080-C32T12	T12	32.00	18.30	80.00	C	S	60000	0.65
MM S-A-L100-W32-T15	T15	32.00	23.90	100.00	W	S	60000	0.30
MM S-A-L100-C40T15	T15	40.00	23.90	100.00	C	S	60000	0.94
MM S-A-L100-C40T21	T21	40.00	30.00	100.00	C	S	60000	1.56

• Do not apply lubricant to the threaded connection.

⁽¹⁾ "B" suffix - cylindrical shank which may be shortened.

⁽²⁾ C-Cylindrical, W-Weldon

⁽³⁾ S-steel

⁽⁴⁾ The maximum RPM must be calculated. Divide the listed max. RPM by the number of flutes (on the milling head) being used.

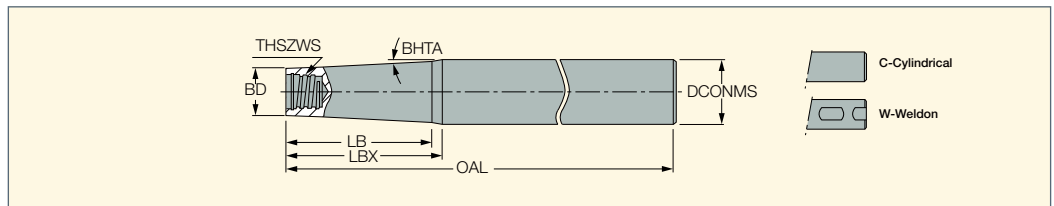
MULTI-MASTER**MM S-B (85° conical shanks)**
Shanks Interchangeable
Milling Heads

Designation	THSZWS	DCONMS	BD	BHTA	Shank ⁽¹⁾	LB	LBX	OAL	Shank m. ⁽²⁾	RPMX ⁽³⁾	kg
MM S-B-L080/24-C08-T04	T04	8.00	5.80	2.6	C	-	24.0	80.00	S	60000	0.04
MM S-B-L080-C12-T05	T05	12.00	7.60	5.0	C	-	25.0	80.00	S	60000	0.06
MM S-B-L085/32-C16T05	T05	16.00	7.60	5.0	C	27.00	32.0	85.00	S	41280	0.11
MM S-B-L125-C16-T06	T06	16.00	9.60	5.0	C	31.50	31.7	125.00	S	41280	0.19
MM S-B-L095/40-C20T06	T06	20.00	9.60	5.0	C	34.00	40.0	95.00	S	41280	0.19
MM S-B-L140-C20-T06-W	T06	20.00	9.65	5.0	C	-	60.3	140.50	W	51180	0.62
MM S-B-L140-C16-T08	T08	16.00	11.60	5.0	C	19.30	22.0	140.00	S	25590	0.22
MM S-B-L100/48-C20T08	T08	20.00	11.60	5.0	C	-	48.0	100.00	S	25590	0.32
MM S-B-L140-C20-T10	T10	20.00	15.30	5.0	C	-	27.0	140.00	S	31020	0.34
MM S-B-L170-C25-T10	T10	25.00	15.30	5.0	C	-	56.0	170.00	S	29490	0.16
MM S-B-L120/55-C25T10	T10	25.00	15.30	5.0	C	-	55.4	120.00	S	29490	0.40
MM S-B-L160-C25-T12	T12	25.00	18.30	5.0	C	-	40.0	160.00	S	28680	0.08
MM S-B-L190-C32-T12	T12	32.00	18.30	5.0	C	-	80.0	190.00	S	34890	0.56
MM S-B-L150/78-C32T12	T12	32.00	18.30	5.0	C	-	78.3	150.00	S	34890	0.78
MM S-B-L200-C32-T15	T15	32.00	23.90	5.0	C	-	50.0	200.00	S	14160	1.19
MM S-B-L180/92-C40T15	T15	40.00	23.90	5.0	C	-	92.0	180.00	S	14160	0.28
MM S-B-L250-W40-T15	T15	40.00	23.90	5.0	W	-	100.0	250.00	S	21840	2.12
MM S-B-L150/57-C40T21	T21	40.00	30.00	5.0	C	-	57.0	150.00	S	21840	0.62

• Do not apply lubricant to the threaded connection.

⁽¹⁾ C-Cylindrical, W-Weldon

⁽²⁾ S-steel, W-tungsten

⁽³⁾ The maximum RPM must be calculated. Divide the listed max. RPM by the number of flutes (on the milling head) being used.

MULTI-MASTER

MM S-D (89° conical shanks)
Shanks Mount Interchangeable
Milling Heads

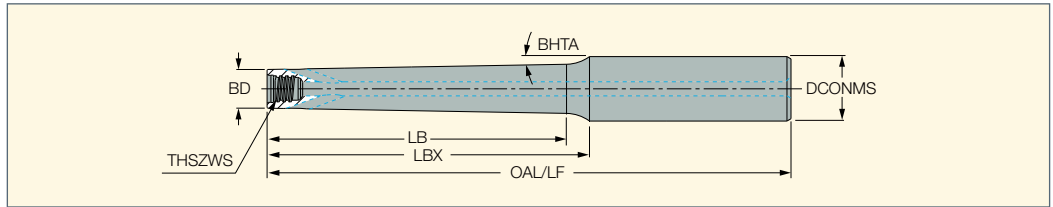

Designation	THSZWS	DCONMS	BD	LB	Shank	LBX	OAL	BHTA	Shankm.	CSP ⁽¹⁾	RPMX ⁽²⁾	
MM S-D-L100-C12-T05	T05	12.00	7.60	29.60	C	35.0	100.00	1.0	S	0	52000	0.08
MM S-D-L110-C12-T05-C	T05	12.00	7.60	55.90	C	60.0	110.00	1.0	C	0	53430	0.13
MM S-D-L110-C12-T05-W-H	T05	12.00	7.60	55.70	C	60.0	110.00	1.0	W	1	38460	0.14
MM S-D-L130-C12-T05-C	T05	12.00	7.60	77.30	C	80.0	130.00	1.0	C	0	36420	0.15
MM S-D-L130-C12-T05-W-H	T05	12.00	7.60	76.40	C	80.0	130.00	1.0	W	1	26160	0.16
MM S-D-L150-C16-T05-C	T05	16.00	7.60	91.50	C	100.0	150.00	1.0	C	0	29700	0.28
MM S-D-L110-C12-T06-W-H	T06	12.00	9.60	58.80	C	60.0	110.00	1.0	W	1	36990	0.17
MM S-D-L130-C16-T06-W-H	T06	16.00	9.60	73.40	C	80.0	130.00	1.0	W	1	29490	0.28
MM S-D-L150-C16-T06-C	T06	16.00	9.60	95.40	C	100.0	150.00	1.0	C	0	30150	0.27
MM S-D-L150-C16-T06-W-H	T06	16.00	9.60	93.80	C	100.0	150.00	1.0	W	1	21660	0.33
MM S-D-L160-C16-T06	T06	16.00	9.60	46.80	C	55.0	160.00	1.0	S	0	23370	0.12
MM S-D-L170-C16-T06-C	T06	16.00	9.60	116.90	C	120.0	170.00	1.0	C	0	23400	0.11
MM S-D-L170-C16-T06-W	T06	16.00	9.60	46.30	C	55.0	170.00	1.0	W	0	21210	0.48
MM S-D-L130-C16-T08-C	T08	16.00	11.60	77.20	C	80.0	130.00	1.0	C	0	39870	0.28
MM S-D-L130-C16-T08-W-H	T08	16.00	11.60	76.40	C	80.0	130.00	1.0	W	1	29040	0.32
MM S-D-L150-C16-T08-C	T08	16.00	11.60	97.80	C	100.0	150.00	1.0	C	0	29970	0.33
MM S-D-L150-C16-T08-W-H	T08	16.00	11.60	98.30	C	100.0	150.00	1.0	W	1	21540	0.38
MM S-D-L170-C20-T08	T08	20.00	11.60	69.70	C	80.0	170.00	1.0	S	0	22680	0.30
MM S-D-L170-C20-T08-C	T08	20.00	11.60	112.00	C	120.0	170.00	1.0	C	0	26250	0.47
MM S-D-L170-C20-T08-W	T08	20.00	11.60	69.70	C	80.0	170.00	1.0	W	0	24900	0.65
MM S-D-L170-C20-T08-W-H	T08	20.00	11.60	113.10	C	120.0	170.00	1.0	W	1	18750	0.53
MM S-D-L150-C20-T10-C	T10	20.00	15.30	97.50	C	100.0	150.00	1.0	C	0	35610	0.10
MM S-D-L150-C20-T10-W-H	T10	20.00	15.30	96.80	C	100.0	150.00	1.0	W	1	25800	0.60
MM S-D-L170-C20-T10-C	T10	20.00	15.30	118.30	C	120.0	170.00	1.0	C	0	28140	0.61
MM S-D-L170-C20-T10-W-H	T10	20.00	15.30	118.00	C	120.0	170.00	1.0	W	1	20100	0.73
MM S-D-L190-C20-T10	T10	20.00	15.30	73.70	C	80.0	190.00	1.0	S	0	15780	0.42
MM S-D-L190-C20-T10-C	T10	20.00	15.30	-	C	140.0	190.00	1.0	C	0	22830	0.68
MM S-D-L190-C20-T10-W-H	T10	20.00	15.30	-	C	140.0	190.00	1.0	W	1	16170	0.83
MM S-D-L210-C20-T10-C	T10	20.00	15.30	-	C	160.0	210.00	1.0	C	0	18270	0.75
MM S-D-L210-C20-T10-W-H	T10	20.00	15.30	-	C	160.0	210.00	1.0	W	1	12870	0.93
MM S-D-L180-C25-T12-C	T12	25.00	18.30	115.70	C	120.0	180.00	1.0	C	0	29460	0.91
MM S-D-L180-C25-T12-W-H	T12	25.00	18.30	114.60	C	120.0	180.00	1.0	W	1	20940	1.15
MM S-D-L200-C25-T12-W-H	T12	25.00	18.30	146.60	C	150.0	200.00	1.0	W	1	16560	1.21
MM S-D-L210-C25-T12	T12	25.00	18.30	94.60	C	100.0	210.00	1.0	S	0	15540	0.66
MM S-D-L250-C25-T12-C	T12	25.00	18.30	135.60	C	140.0	250.00	1.0	C	0	16170	1.40
MM S-D-L250-C25-160T12W-H	T12	25.00	18.30	157.20	C	160.0	250.00	1.0	W	1	11310	1.76
MM S-D-L250-C25-T12-W-H	T12	25.00	18.30	135.60	C	140.0	250.00	1.0	W	1	11300	1.80
MM S-D-L250-C32-T15	T15	32.00	23.90	90.10	C	100.0	250.00	1.0	S	0	14160	1.00
MM S-D-L250-C32-T15-C	T15	32.00	23.90	143.30	C	150.0	250.00	1.0	C	0	20370	1.88
MM S-D-L300-C32-T15-C	T15	32.00	23.90	195.70	C	200.0	300.00	1.0	C	0	16000	2.62

• Shank material (Shank m.): S-steel, C-carbide, W-tungsten. • Do not apply lubricant to the threaded connection.

⁽¹⁾ 0 - Without coolant supply, 1 - With coolant supply

⁽²⁾ The maximum RPM must be calculated. Divide the listed max. RPM by the number of flutes (on the milling head) being used.

MULTI-MASTER**MM S-ER**

Shanks that Mount
MULTI-MASTER Solid
Carbide Heads with an
ER Collet Adaptation

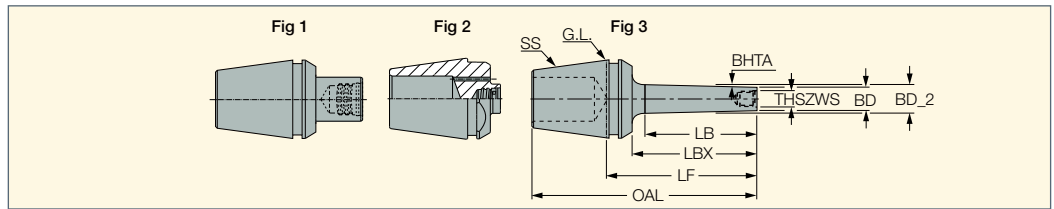

Designation	SS	THSZWS	BHTA	BD	BD_2	LB	LBX	LF	OAL	Fig.	CSP ⁽¹⁾	kg
MM S-A-H004-ER11-T04	ER11	T04	-	5.80	-	-	4.0	9.60	22.00	1	0	0.01
MM S-A-H004-ER11-T05	ER11	T05	-	7.60	-	-	4.0	9.60	22.00	1	0	0.01
MM S-A-H10.5-ER11-T05	ER11	T05	-	7.60	-	-	10.5	16.10	28.50	1	0	0.01
MM S-A-H004-ER16-T05	ER16	T05	-	7.60	-	-	4.0	11.60	31.50	2	1	0.02
MM S-A-H004-ER16-T06	ER16	T06	-	9.25	-	-	4.0	11.60	31.50	2	1	0.03
MM S-A-H004-ER16-T08	ER16	T08	-	11.60	-	-	4.0	11.60	31.50	1	0	0.04
MM S-A-H10.5-ER16-T05	ER16	T05	-	7.60	-	-	10.5	18.10	38.00	1	0	0.03
MM S-A-H10.5-ER16-T06	ER16	T06	-	9.25	-	-	10.5	18.10	38.00	1	0	0.04
MM S-A-H013-ER16-T08	ER16	T08	-	11.60	-	-	14.0	20.60	40.50	1	0	0.02
MM S-A-H004-ER20-T05	ER20	T05	-	7.60	-	-	4.0	12.60	35.50	2	1	0.06
MM S-A-H004-ER20-T06	ER20	T06	-	9.25	-	-	4.0	12.60	35.50	2	1	0.06
MM S-A-H004-ER20-T08	ER20	T08	-	11.60	-	-	4.0	12.60	35.50	2	1	0.07
MM S-A-H004-ER20-T10	ER20	T10	-	15.30	-	-	4.0	12.60	35.50	1	0	0.06
MM S-A-H10.5-ER20-T05	ER20	T05	-	7.60	-	-	10.5	19.10	42.00	1	0	0.04
MM S-A-H10.5-ER20-T06	ER20	T06	-	9.25	-	-	10.5	19.10	42.00	1	0	0.05
MM S-A-H013-ER20-T08	ER20	T08	-	11.60	-	-	13.0	21.60	44.50	2	1	0.07
MM S-A-H016-ER20-T10	ER20	T10	-	15.30	-	-	16.0	24.60	47.50	1	0	0.07
MM S-A-H004-ER25-T05	ER25	T05	-	7.60	-	-	4.0	13.10	38.00	2	1	0.08
MM S-A-H10.5-ER25-T05	ER25	T05	-	7.60	-	-	10.5	19.60	44.50	2	1	0.08
MM S-A-H004-ER25-T06	ER25	T06	-	9.25	-	-	4.0	13.10	38.00	2	1	0.07
MM S-A-H10.5-ER25-T06	ER25	T06	-	9.25	-	-	10.5	19.60	44.50	2	1	0.12
MM S-A-H004-ER25-T08	ER25	T08	-	11.60	-	-	4.0	13.10	38.00	2	1	0.11
MM S-A-H10.5-ER25-T08	ER25	T08	-	11.60	-	-	10.5	19.60	44.50	2	1	0.06
MM S-A-H004-ER25-T10	ER25	T10	-	15.30	-	-	4.0	13.10	38.00	2	1	0.10
MM S-A-H10.5-ER25-T10	ER25	T10	-	15.30	-	-	10.5	19.60	44.50	2	1	0.10
MM S-A-H004-ER25-T12	ER25	T12	-	18.30	-	-	4.0	13.10	38.00	1	0	0.10
MM S-A-H10.5-ER25-T12	ER25	T12	-	18.30	-	-	10.5	19.60	44.50	1	0	0.06
MM S-A-H025-ER32-T06	ER32	T06	-	9.25	10.00	18.00	25.0	35.10	65.00	3	0	0.15
MM S-B-H025-ER32-T06	ER32	T06	5.0	9.60	13.50	22.30	25.0	35.10	65.00	3	0	0.16
MM S-B-H050-ER32-T06	ER32	T06	5.0	9.60	17.90	47.30	50.0	60.10	90.00	3	0	0.20
MM S-B-H075-ER32-T06	ER32	T06	5.0	9.60	22.60	74.10	75.0	85.10	115.00	3	0	0.25
MM S-D-H050-ER32-T06	ER32	T06	1.0	9.60	11.20	45.00	50.0	60.10	90.00	3	0	0.17

• Do not apply lubricant to the threaded connection. • For adaptation see page 9 • When a rigid ER collet is assembled in an ER holder, the actual protruding length of the holder becomes shorter by 2.0 mm for ER20 and by 3.0 mm for ER25/ER32

⁽¹⁾ 0 - Without coolant supply, 1 - With coolant supply

MULTI-MASTER**MM S-ER-H**

Shanks that Mount
MULTI-MASTER Solid Carbide
Heads with an ER Collet
Adaptation and Coolant Holes

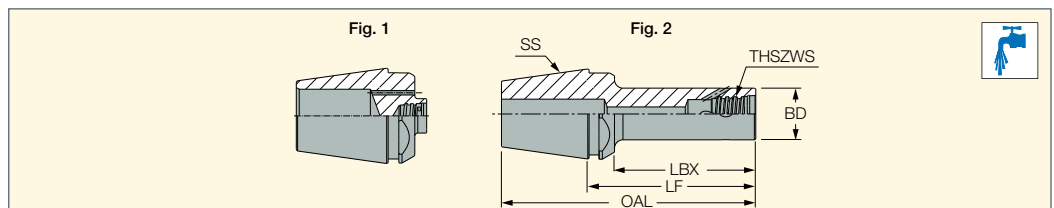

Designation	SS	THSZWS	BD	LBX	LF	OAL	Fig.	kg
MM S-A-H004-ER32-T05-H	ER32	T05	7.60	4.0	14.10	44.00	1	0.14
MM S-A-H025-ER32-T05-H	ER32	T05	7.60	25.0	35.10	65.00	2	0.20
MM S-A-H040-ER32-T05-H	ER32	T05	7.60	40.0	50.10	80.00	2	0.15
MM S-A-H004-ER32-T06-H	ER32	T06	9.60	4.0	14.10	44.00	1	0.14
MM S-A-H025-ER32-T06-H	ER32	T06	9.25	25.0	35.10	65.00	2	0.20
MM S-A-H040-ER32-T06-H	ER32	T06	9.25	40.0	50.10	80.00	2	0.22
MM S-A-H004-ER32-T08-H	ER32	T08	11.60	4.0	14.10	44.00	1	0.16
MM S-A-H025-ER32-T08-H	ER32	T08	11.60	25.0	35.10	65.00	2	0.20
MM S-A-H050-ER32-T08-H	ER32	T08	11.60	50.0	60.10	90.00	2	0.23
MM S-A-H004-ER32-T10-H	ER32	T10	15.30	4.0	14.10	44.00	1	0.14
MM S-A-H025-ER32-T10-H	ER32	T10	15.30	25.0	35.10	65.00	2	0.20
MM S-A-H050-ER32-T10-H	ER32	T10	15.20	50.0	60.10	90.00	2	0.25
MM S-A-H004-ER32-T12-H	ER32	T12	18.30	4.0	14.10	44.00	1	0.14
MM S-A-H025-ER32-T12-H	ER32	T12	18.30	25.0	35.10	65.00	2	0.22
MM S-A-H050-ER32-T12-H	ER32	T12	18.30	50.0	60.10	90.00	2	0.22
MM S-A-H004-ER32-T15-H	ER32	T15	23.90	4.0	14.10	44.00	1	0.16
MM S-A-H025-ER32-T15-H	ER32	T15	23.90	25.0	35.10	65.00	2	0.21
MM S-A-H050-ER32-T15-H	ER32	T15	23.90	50.0	60.10	90.00	2	0.25

• Do not apply lubricant to the threaded connection.

MULTI-MASTER HSK**MM S-A-HSK**

MULTI-MASTER Threaded Connection Shanks with an Integral HSK DIN 69893 Form A Tapered Adaptation

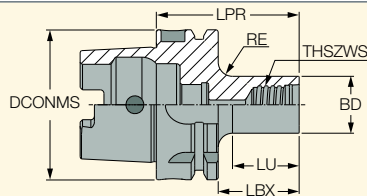

Designation	DCONMS	THSZWS	BD	LPR	LBX	LU	RE	CDI ⁽¹⁾	kg
MM S-A-H035-HSK A40-T05	40.00	T05	7.60	35.00	15.0	10.00	5.0	1	0.20
MM S-A-H040-HSK A40-T06	40.00	T06	9.25	40.00	20.0	15.00	5.0	1	0.28
MM S-A-H045-HSK A40-T08	40.00	T08	11.60	45.00	25.0	20.00	5.0	1	0.24
MM S-A-H050-HSK A40-T10	40.00	T10	15.30	50.00	30.0	25.00	5.0	1	0.23
MM S-A-H050-HSK A40-T12	40.00	T12	18.30	50.00	30.0	25.00	5.0	1	0.27
MM S-A-H050-HSK A63-T06	63.00	T06	9.25	50.00	24.0	18.00	6.0	1	0.70
MM S-A-H050-HSK A63-T08	63.00	T08	11.60	50.00	24.0	18.00	6.0	1	0.72
MM S-A-H055-HSK A63-T10	63.00	T10	15.30	55.00	29.0	23.00	6.0	1	0.73
MM S-A-H055-HSK A63-T12	63.00	T12	18.30	55.00	29.0	23.00	6.0	1	0.40
MM S-A-H060-HSK A63-T15	63.00	T15	23.90	60.00	34.0	28.00	6.0	1	0.76

• Do not apply lubricant to the threaded connection • For adaptation options, see page 9

⁽¹⁾ 1 - Slot for data chip, 0 - Without slot for data chip

MULTI-MASTER**DIN69871****MM S-A-SK**

DIN 69871 Integral Tapered Shanks Mount MULTI-MASTER Milling Heads

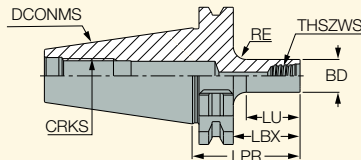

Designation	DCONMS	CRKS	THSZWS	BD	LPR	LBX	LU	RE	kg
MM S-A-H040-SK 40-T06	40.00	M16	T06	9.25	40.00	21.0	15.00	6.0	0.86
MM S-A-H045-SK 40-T08	40.00	M16	T08	11.60	45.00	26.0	20.00	6.0	0.87
MM S-A-H050-SK 40-T10	40.00	M16	T10	15.30	50.00	31.0	25.00	6.0	0.83
MM S-A-H050-SK 40-T12	40.00	M16	T12	18.30	50.00	31.0	25.00	6.0	0.90
MM S-A-H050-SK 40-T15	40.00	M16	T15	23.90	50.00	31.0	25.00	6.0	0.93

• Do not apply lubricant to the threaded connection • For adaptation options, see page 9

MULTI-MASTER**CAMFIX****MM S-A-C#**

MULTI-MASTER Threaded Connection Shanks with a CAMFIX (ISO 26623-1) Exchangeable Adaptation

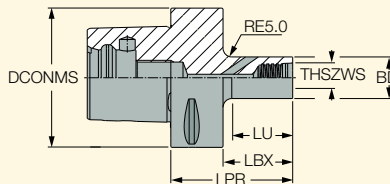

Designation	DCONMS	THSZWS	BD	LPR	LBX	LU	CDI ⁽¹⁾	kg
MM S-A-H035-C3-T05	32.00	T05	7.60	35.00	20.0	15.00	0	0.12
MM S-A-H035-C3-T06	32.00	T06	9.25	35.00	20.0	15.00	0	0.12
MM S-A-H040-C3-T08	32.00	T08	11.60	40.00	25.0	20.00	0	0.13
MM S-A-H040-C3-T10	32.00	T10	15.30	40.00	25.0	20.00	0	0.15
MM S-A-H045-C3-T12	32.00	T12	18.30	45.00	30.0	25.00	0	0.16
MM S-A-H045-C4-T06	40.00	T06	9.25	45.00	25.0	20.00	0	0.25
MM S-A-H045-C4-T08	40.00	T08	11.60	45.00	25.0	20.00	0	0.25
MM S-A-H050-C4-T10	40.00	T10	15.30	50.00	30.0	25.00	0	0.28
MM S-A-H055-C4-T12	40.00	T12	18.30	55.00	35.0	30.00	0	0.22
MM S-A-H055-C4-T15	40.00	T15	23.90	55.00	35.0	30.00	0	0.35
MM S-A-H060-C5-T10	50.00	T10	15.30	60.00	40.0	35.00	0	0.22
MM S-A-H060-C5-T12	50.00	T12	18.30	60.00	40.0	35.00	0	0.48
MM S-A-H060-C5-T15	50.00	T15	23.90	60.00	40.0	35.00	0	0.58
MM S-A-H065-C6-T12	63.00	T12	18.30	65.00	43.0	38.00	0	0.80
MM S-A-H065-C6-T15	63.00	T15	23.90	65.00	43.0	38.00	0	0.84
MM S-A-H070-C8-T15	80.00	T15	23.90	70.00	40.0	35.00	0	1.83

• Do not apply lubricant to the threaded connection • For adaptation options, see page 9

⁽¹⁾ 1 - Slot for data chip, 0 - Without slot for data chip

MULTI-MASTER**MM CAB-T-T**

MULTI-MASTER Shank Extensions

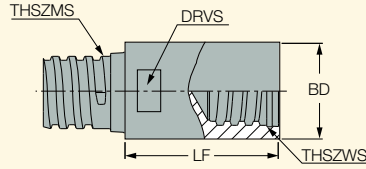

Designation	BD	THSZWS	THSZMS	LF	DRVS ⁽¹⁾	kg
MM CAB T05T05-25/1.0-C	7.60	T05	T05	25.40	6.0	0.02
MM CAB T06T06-25/1.0-C	9.30	T06	T06	25.40	8.0	0.02
MM CAB T08T08-25/1.0-C	11.50	T08	T08	25.40	10.0	0.02
MM CAB T10T10-38/1.5-C	15.20	T10	T10	38.10	13.0	0.08
MM CAB T12T12-38/1.5-C	18.45	T12	T12	38.10	16.0	0.11
MM CAB T15T15-45/1.77-C	23.90	T15	T15	45.00	20.0	0.21

• Clamping key to be ordered separately • For adaptation options, see page 9

⁽¹⁾ Clamping wrench size

MULTI-MASTER**MM CAB-T-T-W**

MULTI-MASTER Shank Reducers

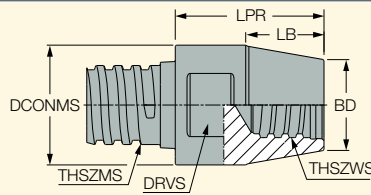

Designation	DCONMS	THSZMS	THSZWS	BD	LB	LPR	DRVS ⁽¹⁾	kg
MM CAB T05T04-14.0/.55-W	7.60	T05	T04	5.80	8.20	14.00	5.5	0.01
MM CAB T06T05-15.0/.59-W	9.60	T06	T05	7.60	9.00	15.00	8.0	0.03
MM CAB T08T06-16.0/.63-W	12.70	T08	T06	9.60	9.00	16.00	10.0	0.04
MM CAB T10T08-19.0/.75-W	15.30	T10	T08	11.60	10.00	19.00	13.0	0.07
MM CAB T12T10-24.0/.94-W	19.00	T12	T10	15.30	15.00	24.00	16.0	0.12
MM CAB T15T12-30.0/1.18-W	24.00	T15	T12	18.30	17.50	30.00	20.0	0.24

• Clamping key to be ordered separately • For adaptation options, see page 9

⁽¹⁾ Torque key size

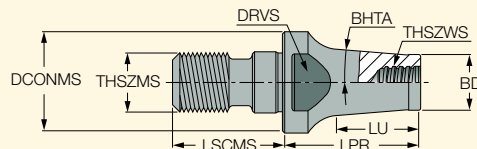
FLEXFIT**MULTI-MASTER****MM CAB**Adapters for Connecting
FLEXFIT Shanks and
MULTI-MASTER Milling Heads

Designation	THSZWS	THSZMS	LPR	LU	BD	DCONMS	LSCMS	DRVS ⁽¹⁾	BHTA	TQ_3 ⁽²⁾	kg
MM CAB T06M06-16/.63	T06	M06	16.00	11.60	9.30	9.70	14.50	8.0	1.5	15	0.01
MM CAB T06M08-16/.63	T06	M08	16.00	13.70	9.60	13.00	17.50	11.0	6.0	20	0.02
MM CAB T06M08-25/1.0	T06	M08	25.00	11.30	9.30	13.00	17.50	11.0	1.5	20	0.02
MM CAB T06M10-25/1.0	T06	M10	25.00	16.60	9.60	18.00	20.00	11.0	5.0	29	0.04
MM CAB T08M08-16/.63	T08	M08	16.00	5.40	11.70	13.00	17.50	11.0	11.4	20	0.03
MM CAB T08M08-25/1.0	T08	M08	25.00	19.50	11.70	13.00	17.50	11.0	1.5	20	0.03
MM CAB T08M10-20/.75	T08	M10	20.00	11.30	11.70	18.00	20.00	13.0	7.0	29	0.04
MM CAB T08M10-25/1.0	T08	M10	25.00	14.20	11.70	18.00	20.00	11.0	1.5	29	0.03
MM CAB T08M12-20/.75	T08	M12	20.00	9.30	11.70	21.00	22.00	13.0	7.0	33	0.05
MM CAB T08M12-25/1.0	T08	M12	25.00	12.50	11.70	21.00	22.00	13.0	1.5	33	0.04

• Do not apply lubricant to the threaded connection • When mounting items with FLEXFIT threaded adaptation to their holders, the mating surfaces and threaded areas must be thoroughly cleaned. Apply appropriate tightening torque to eliminate a gap between the mating faces. Estimated torque values are specified in the TQ_3 parameter

⁽¹⁾ Clamping wrench size

⁽²⁾ Tool tightening torque Nxm (lbfxin)

T-SLOT

MULTI-MASTER

SD CAB

Adapters for Connecting SD Solid Carbide T-Slot Milling Heads and MULTI-MASTER Shanks

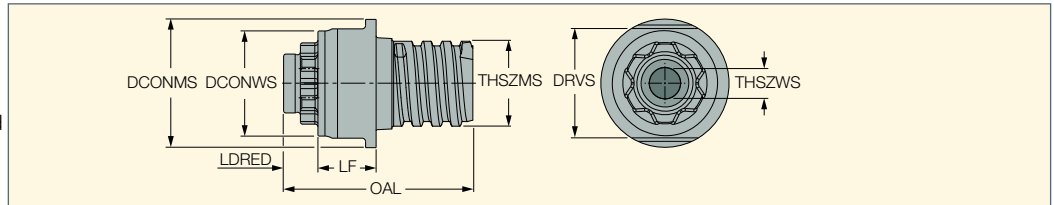





Designation	THSZWS	THSZMS	LF	LDRED	OAL	DCONWS	DCONMS	DRVS ⁽¹⁾	kg
SD CAB T10-14/0.55-SP11	M4x0.5	T10	14.00	3.9	29.15	11.00	15.20	13.0	0.02
SD CAB T12-14/0.55-SP13	M4x0.5	T12	14.00	4.3	31.65	13.00	18.30	16.0	0.04
SD CAB T12-14/0.55-SP15	M5x0.5	T12	14.00	4.9	32.70	15.00	18.30	16.0	0.04
SD CAB T15-14/0.55-SP17	M6x0.5	T15	14.00	6.0	37.00	17.00	23.90	20.0	0.07
SD CAB T15-14/0.55-SP19	M6x0.5	T15	14.00	8.5	39.50	19.00	23.90	20.0	0.07

• Note: Apply lubricant to the MULTI-MASTER threaded connection and to the slotting head clamping screw

⁽¹⁾ Clamping wrench size

Spare Parts

Designation				
SD CAB T10-14/0.55-SP11	SR M4X0.5-SP11 HG	BLD T15/S7	SW6-T-SH	MM KEY 13X8*
SD CAB T12-14/0.55-SP13	SR M4X0.5-SP13-IP15-HG	BLD IP15/S7	SW6-T-SH	
SD CAB T12-14/0.55-SP15	SR M5X0.5-SP15-IP20-HG	BLD IP20/S7	SW6-T-SH	
SD CAB T15-14/0.55-SP17	SR M6X0.5-SP17-IP20-HG	BLD IP20/S7	SW6-T-SH	
SD CAB T15-14/0.55-SP19	SR M6X0.5-SP17-IP20-HG ^(a)	BLD IP20/S7	SW6-T-SH	

* Optional, to be ordered separately

^(a) Recommended tightening torque: 10.0 N*m



ALPHABETICAL INDEX

B	BCM-MM	45
C	CH45-MM-PN06	51
D	DCN-MM	57
E	E90SO-MM-04	26
	E93CN-MM-07	39
	ETS-LN08-MM	64
F	FF EWX-MM	33
	FFT3 EFM-MM 02	32
	FFT3 EFM-MM 03	32
	FFX4 ED-MM	33
H	H490 E90AX-MM	26
	H690 EWN-MM-04	29
	HCE-MM	28
	HCM-MM	45
	HM90 E90A-MM-10	26
	HM90 E90A-MM-10-JHP	28
	HM390 ETC-MM	27
	HM390 ETP-MM-04	27
	HM390 ETP-MM-05	27
	HP E90AN-MM-07	25

M	MM Adjustable Torque Keys	11
	MM CAB	83
	MM CAB-T-T	83
	MM CAB-T-T-W	83
	MM EA	21
	MM EA-CF	22
	MM EB	35
	MM EBA	36
	MM EBC	37
	MM EC-3	15
	MM EC-4	16
	MM EC-6	17
	MM EC-8/10	18
	MM EC-CF	18
	MM EC-CF-Z7/9-1.5xD	23
	MM EC-D	17
	MM ECD	55
	MM ECDF	56
	MM ECF	47
	MM EC-H-4-CF	19
	MM EC-H-5-CF	19
	MM ECK-CF	24
	MM ECS	54
	MM ECU	15

M	MM EC-Z4-1.5xD	23
	MM EDF	48
	MM EFCB	55
	MM EFF	31
	MM EFS	19
	MM EFS-CF	20
	MM ELB	37
	MM EOB	38
	MM EPG	52
	MM ER	49
	MM ERA	21
	MM ERS	20
	MM ERS-1.5xD	22
	MM ESR-1.5D BLANKS	74
	MM ESR BLANKS	74
	MM ET	38
	MM ETR	36
	MM FF	30
	MM FM	15
	MM GRIT-4T8	60
	MM GRIT-16K/P,18K/P 3T6	59
	MM GRIT 28P-DR	50
	MM GRIT-45A	48
	MM GRIT Dovetail	49

M	MM GRT (shanks)	78
	MM HBR	34
	MM HC	24
	MM HCD	46
	MM HCR	34
	MM HDF	47
	MM HR	50
	MM HRF	34
	MM HT	35
	MM S-A-C#	82
	MM S-A-HSK	82
	MM S-A-N	78
	MM S-A-SK	82
	MM S-A (stepped shanks)	76
	MM S-A (stepped shanks)	77
	MM S-A (straight shanks)	79
	MM S-B (85° conical shanks)	79
	MM S-D (89° conical shanks)	80
	MM S-ER	81
	MM S-ER-H	81
	MM SS	63
	MM TC-G	73
	MM TRD-M	68
	MM TRD-W	69

M	MM TRF 55°	69
	MM TRF 60°	70
	MM TS-45	48
	MM TS-A	78
	MM TS-C	62
	MM TS-DG	63
	MM TS-H	62
	MM TS-N	61
	MTE-MM	71
	MT-ISO-MM	66
	MT-UN-MM	67
	MT-W-MM	68
S	SD CAB	84
	SGSF/A-MM-JHP	64
T	T290 ELN-MM-05	25
	T490 ELN-MM-08	25
	TGSF-MM-JHP	64

ISCAR LTD.

Israel
Headquarters
 Tel +972 (0)4 997 0311
 Fax+972 (0)4 987 3741
 headquarter@iscar.co.il

Argentina
 ISCAR TOOLS ARGENTINA SA
 Tel +54 114 912 2200
 Fax+54 114 912 4411
 admin@iscararg.com.ar

Australia
 ISCAR AUSTRALIA PTY. LTD
 Tel +61 (0) 2 8848 3500
 Fax+61 (0) 2 8848 3511
 iscaraus@iscar.com.au

Austria
 ISCAR AUSTRIA GmbH
 Tel +43 7252 71200-0
 Fax+43 7252 71200-999
 office@iscar.at

Belarus
 JV ALC "TWINING-M"
 Tel +375 17 506-32-38
 +375 17 506-33-31/65
 Tel/Fax +375 17 506-32-37
 info@twing.by
 www.twing.by

Belgium
 n.v. ISCAR BENELUX s.a.
 Tel +32 (0) 2 464 2020
 Fax+32 (0) 2 522 5121
 info@iscar.be

Bosnia
 (Representative Office)
 Tel +387 32 201 100
 Fax+387 32 201 101
 info@iscar.ba

Brazil
 ISCAR DO BRASIL COML. LTDA.
 Tel +55 19 3826-7100
 Fax+55 19 3826-7171
 DDG 0800 701 8877
 iscar@iscarbrasil.com.br

Bulgaria
 ISCAR BULGARIA
 Tel/Fax +359 431 62557
 aa_iscar@infotel.bg

Canada
 ISCAR TOOLS INC.
 Tel +1 905 829 9000
 Fax+1 905 829 9100
 admin@iscar.ca

Chile
 J&A INTERNATIONAL
 Tel +56 2 2232 5838
 amedina@jya.cl
 www.jya.cl

China
 ISCAR CHINA
 Tel +86 21 8024 8888
 iscar@iscar.com.cn

Colombia
 ISCAR Andina
 Tel +57 310 380 9932
 Tel/fax +57 1 896 65 78
 iscar@iscar.com.co

Croatia
 ISCAR ALATI d.o.o.
 Tel +385 (0) 1 33 23 301
 Fax+385 (0) 1 33 76 145
 podrska@iscar.hr

Cyprus
 WAMET (Demetriades) Ltd.
 Tel +357 (0) 2 336660/5498
 Fax+357 (0) 2 333386
 wamet@cytanet.com.cy

Czech Republic
 ISCAR CR s.r.o.
 Tel +420 377 420 625
 Fax+420 377 420 630
 iscar@iscar.cz

Denmark
 KJ VAERKTOEJ AS/ISCAR DENMARK
 Tel +45 70 11 22 44
 Fax+45 46 98 67 10
 kj@kj.dk

Ecuador
 ISCAR Andina
 Tel/fax +57 1 821 93 38
 iscar@iscar.com.co
 atencioncliente@iscar.com.co

Estonia
 KATOMSK AS
 Tel +372 6775 671
 Fax+372 6720 266
 aleksei@katomsk.ee

Finland
 ISCAR FINLAND OY
 Tel +358-(0)9-439 1420
 Fax+358-(0)9-466 328
 info@iscar.fi

France
 ISCAR FRANCE SAS
 Tel +33 (0)1 30 12 92 92
 Fax+33 (0)1 30 12 95 82
 info@iscar.fr

Germany
 ISCAR Germany GmbH
 Tel +49 (0) 72 43 9908-0
 Fax+49 (0) 72 43 9908-93
 gmbh@iscar.de
 www.iscar.de

Greece
 INTERNATIONAL TOOLS
 K.-X. GEORGOPOULOS & SIA O.E
 Tel +30 210 346 0133
 Fax+30 210 342 5621
 info@internationaltools.gr

VIMA
 V. Mazlounian & Sons
 Tel +30 2310 517-117 / 544-521
 Fax+30 2310 529-107
 vimaco@otenet.gr
 http://www.vimaco.gr

Hong Kong
 MTC TOOLING SYSTEMS LTD
 Tel +85-2-23054838
 Fax+85-2-27988789
 yoongkamsing@hotmail.com

Hungary
 ISCAR HUNGARY KFT.
 Tel +36 28 887 700
 Fax+36 28 887 710
 iscar@iscar.hu

India
 ISCAR India Ltd.
 Tel +91 77009 63707
 sales@iscar.in

Indonesia
 CV MULTI TEKNIK
 Tel +62-21-29206242/44/45/59
 Fax+62-21-29206243
 contact@multi-teknik.co.id

Ireland
 HARD METAL MACHINE TOOLS
 Tel +353 (0) 1 286 2466
 Fax+353 (0) 1 286 1514
 phannigan@hardmetal.ie
 www.hardmetal.ie

Italy
 ISCAR ITALIA srl
 Tel +39 02 93 528 1
 Fax+39 02 93 528 213
 marketing@iscaritalia.it

Japan
 ISCAR JAPAN LTD.
 Tel +81 6 6835 5471
 Fax+81 6 6835 5472
 iscar@iscar.co.jp

Latvia
 MECHA, UAB
 Tel +370 37 407 230
 Fax+370 37 407 231
 info@mecha.lt

Lithuania
 MECHA, UAB
 Tel +370 37 407 230
 Fax+370 37 407 231
 sigitas@mecha.lt

Mexico
 ISCAR DE MÉXICO
 Tel +52 (442) 214 5505
 Fax+52 (442) 214 5510
 iscarmex@iscar.com.mx

The Netherlands
 ISCAR NEDERLAND B.V.
 Tel +31 (0) 182 535523
 Fax+31 (0) 182 572777
 info@iscar.nl

New Zealand
 ISCAR PACIFIC LTD.
 Tel +64 (0) 9 573 1280
 Fax+64 (0) 9 573 0781
 iscar@iscarpac.co.nz

North Macedonia
 (Representative Office)
 Tel +389 2 309 02 52
 Fax+389 2 309 02 54
 info@iscar.com.mk

Norway
 SVEA MASKINER AS
 Tel +47 32277750
 Fax+47 32277751
 per.martin.bakken@svea.no

Peru
 HARTMETALL SAC
 Tel: (511) 6612699
 otorres@hartmetallgroup.com

Philippines
 MESCO
 Tel +63 2631 1775
 Fax+63 2635 0276
 mesco@mesco.com.ph

Poland
 ISCAR POLAND Sp. z o.o.
 Tel +48 32 735 7700
 Fax+48 32 735 7701
 iscar@iscar.pl

Portugal
 ISCAR Portugal, SA
 Tel +351 256 579950
 Fax+351 256 586764
 info@iscarportugal.pt

Romania
 ISCAR Tools SRL
 Tel +40 (0)312 286 614
 Fax+40 (0)312 286 615
 iscar-romania@iscar.com

Russia
 Moscow
 ISCAR LLC
 Tel/fax +7 495 660 91 25/31
 iscar@iscar.ru

Serbia
 ISCAR TOOLS d.o.o.
 Tel +381 11 314 90 38
 Fax+381 11 314 91 47
 info@iscartools.rs

Singapore
 SINO TOOLING SYSTEM
 Tel +65 6566 7668
 Fax+65 6567 7336
 sinotool@singnet.com.sg

Slovakia
 ISCAR SR, s.r.o.
 Tel +421 (0) 41 5074301
 Fax+421 (0) 41 5074311
 info@iscar.sk

Slovenia
 ISCAR SLOVENIJA d.o.o.
 Tel +386 1 580 92 30
 Fax+386 1 562 21 84
 info@iscar.si

South Africa
 ISCAR SOUTH AFRICA (PTY) LTD.
 ShareCall 08600-47227
 Tel +27 11 997 2700
 Fax+27 11 388 9750
 iscar@iscarsa.co.za

South Korea
 ISCAR KOREA
 Tel +82 53 760 7594
 Fax+82 53 760 7500
 leeyj@taegutech.co.kr

Spain
 ISCAR IBERICA SA
 Tel +34 93 594 6484
 Fax+34 93 582 4458
 iscar@iscarib.es

Sweden
 ISCAR SVERIGE AB
 Tel +46 (0) 18 66 90 60
 Fax+46 (0) 18 122 920
 info@iscar.se

Switzerland
 ISCAR HARTMETALL AG
 Tel +41 (0) 52 728 0850
 Fax+41 (0) 52 728 0855
 office@iscar.ch

Taiwan
 ISCAR Taiwan Ltd.
 Tel +886 (0)4-24731573
 Fax+886 (0)4-24731530
 iscar.taiwan@msa.hinet.net

Thailand
 ISCAR Thailand Ltd.
 Tel +66 (2) 7136633-8
 Fax+66 (2) 7136632
 iscar@iscarthailand.com

Turkey
 ISCAR Kesici Takim
 TIC. VE. IML. LTD
 Tel +90 (262) 751 04 84 (Pbx)
 Fax+90 (262) 751 04 85
 iscar@iscar.com.tr

Ukraine
 ISCAR UKRAINE LLC
 Tel +38 (050) 440 23 91
 info@iscar.com.ua

United Arab Emirates
 SVRS General Trading LLC
 Tel +971 4 342 6699
 www.svrs-mena.com

United Kingdom
 ISCAR TOOLS LTD.
 Tel +44 (0) 121 422 8585
 Fax+44 (0) 121 423 2789
 sales@iscar.co.uk

United States
 ISCAR METALS INC.
 Tel +1 817 258 3200
 Tech Tel 1-877-BY-ISCAR
 Fax+1 817 258 3221
 info@iscarmetals.com

Venezuela
 FERREINDUSTRIAL ISO-DIN C.A.
 Tel +58 2 632 8211/633 4657
 Fax+58 2 632 5277
 iso-din@cantv.net

Vietnam
 ISCAR VIETNAM
 (Representative Office)
 Tel +84 8 38 123 519/20
 Fax+84 8 38 123 521
 iscarvn@hcm.fpt.vn

www.iscar.com

Please check ISCAR's online catalog for the most current technical information regarding our products



ISCAR **MULTI-MASTER** LINES

SOLID CARBIDE & INDEXABLE HEADS

Metric Catalog

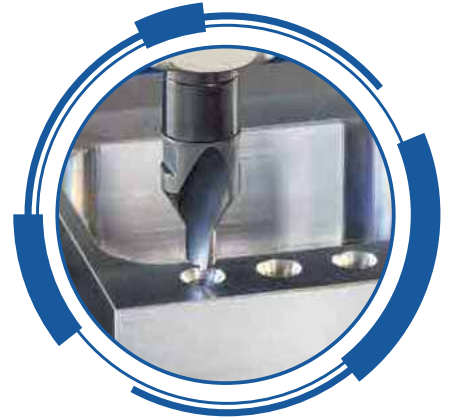
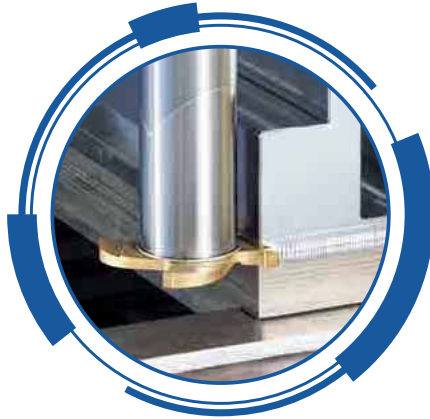
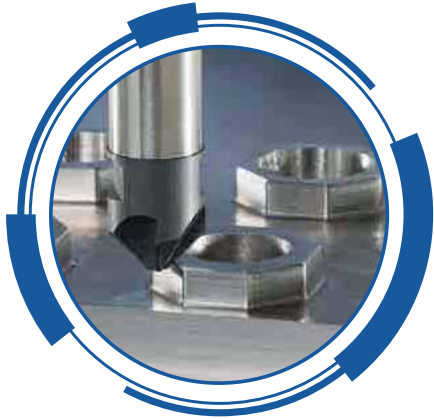
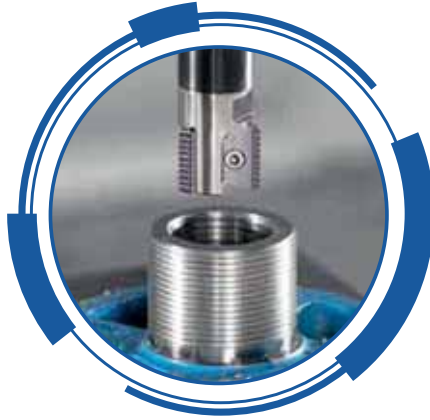

Download **ISCAR WORLD APP**



E-CAT



Erich Klingseisen KG Brunnenstraße 2 78554 Aldingen

Tel. (07424) 98192-0
info@klingseisen.de

Fax. (07424) 84601
www.klingseisen.de



© ISCAR
All rights reserved
Recyclab