

Small-diameter deep hole drilling via innovative *grinding technology*

Coolant through motor spindle

CTM-4020

Tool shank diameter $\phi 3.0$ – $\phi 6.35$ mm

A new motor spindle capable of 30 MPa high-pressure coolant has been added to the product line, which performs processing by compressively injecting coolant from the rear of the spindle and discharging it at the tool tip. Coolant can be sufficiently discharged even with small-diameter tools of $\phi 0.5$ mm, resulting in good chip evacuation, improved processing accuracy and shorter processing time.



Drilling data

Drilling $\phi 0.5$ mm \times depth 6 mm (L/D = 12)

Motor spindle	CTM-4020	Hole depth	6 mm, through hole L/D = 12
Tool	Drill with through coolant holes (Mitsubishi Materials/MWS0050XB-VP15TF)	Coolant	Water-insoluble, internal lubrication at 30 MPa
Workpiece material	Stainless steel 303	Pilot hole	depth 1 mm

	Tool manufacturer's recommended conditions	Nakanishi's proposed conditions
Cutting speed [m/min]	20	31
Motor speed [min ⁻¹]	12,700	20,000
Feed rate [mm/rev]	0.008	0.01
Feed speed [mm/min]	100	200
Peck drilling cycle	-	No pecking

Productivity
2
times



Specifications

Code No.: 7918

Model: CTM-4020

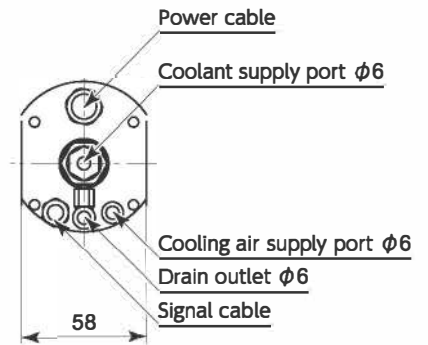
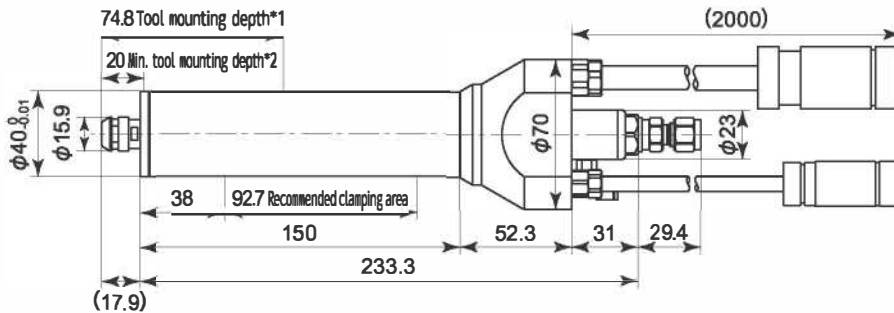

*1 For φ4-φ6.35 mm shank tool.

(For less than φ4 mm shank tool, it is a through hole.)

*2 If the tool is not inserted more than 20 mm from the tip of the collet, coolant will leak from the collet.







O.D.	Max. rotation speed	Spindle accuracy	Max. power	Net weight	Coolant pressure
φ40 mm	20,000 min ⁻¹	Within 1 μm	1,200 W	2.6 kg	0.5-30 MPa

Standard equipment and accessories

Collet nut (K-265) / Wrench(12 × 14): 2 pcs.

*Collet is sold separately. Select the suitable size from the collet CHK-OH group.

Combination example

Collet	Motor spindle	Motor cord	Controller	Air line kit
 CHK-OH φ3.0-φ6.35 mm	 CTM-4020 Grip ring  GR-40	 Power cable 2 m/4 m/6 m EMCD-4000-2M/4M/6M  Signal cable 2 m/4 m/6 m EMCD-4000S-2M/4M/6M	 E4000 CONTROLLER	 AL-C1204 *Supply cooling air

Drilling example

Drilling φ2.0 mm × depth 19 mm through holes

- Motor spindle: CTM-4020
- Processing machine: multitasking machine OKUMA MULTUS U3000
- Tool: drill with through coolant holes
(Mitsubishi Materials/MVS0200X12S030)
- Workpiece material: soft magnetic iron (ELCH2)
- Coolant: water soluble, internal lubrication at 3 MPa

Peck drilling
5 times
No pecking

	Current conditions	Nakanishi's proposed conditions
Cutting speed [m/min]	40	125
Motor speed [min ⁻¹]	6,400	20,000
Feed rate [mm/rev]	0.03	0.06
Feed speed [mm/min]	192	1,200
Peck drilling cycle	Front: 3.5 mm × 3 times Rear: 4.0 mm × 2 times	No pecking

Productivity **6.25 times**



NAKANISHI INC.

700 Shimohinata, Kanuma, Tochigi 322-8666, Japan
TEL: +81 289 64 3520 FAX: +81 289 62 1135

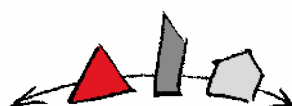

Werkzeuge & Maschinen

en.nakanishi-spindle.com
NAKANISHI INC. 2025

PR-K405E Ver.1 2024-12-17 XXX.YX [XX]

